

ICC-ES Evaluation Report

ESR-2620*

Reissued July 1, 2011

This report is subject to renewal in two years.

www.icc-es.org | (800) 423-6587 | (562) 699-0543

A Subsidiary of the International Code Council®

DIVISION: 05 00 00—METALS
Section: 05 40 00—Cold-Formed Metal Framing

DIVISION: 09 00 00—FINISHES
Section: 09 22 16.13—Non-Structural Metal Stud Framing

REPORT HOLDER:

WARE INDUSTRIES, INC. (DBA Marino\WARE)
 400 METUCHEN ROAD
 SOUTH PLAINFIELD, NEW JERSEY 07080
 (908) 757-9000
www.marinoware.com

EVALUATION SUBJECT:

VIPERSTUD DRYWALL FRAMING SYSTEM (NONLOAD-BEARING): VIPER25, VIPER20, VIPER 27MIL, VIPER 30MIL, VIPER 33MIL

ADDITIONAL LISTEE:

CALIFORNIA EXPANDED METAL COMPANY (CEMCO)
 263 NORTH COVINA LANE
 CITY OF INDUSTRY, CALIFORNIA 91746
 (800) 775-2362
www.cemcosteel.com

TELLING INDUSTRIES, LLC
 6272 CENTER STREET
 MENTOR, OHIO 44060
 (440) 974-3370
www.tellingindustries.com

1.0 EVALUATION SCOPE
Compliance with the following codes:

- 2009 and 2006 *International Building Code*® (IBC)
- 2009 and 2006 *International Residential Code*® (IRC)

Property evaluated:

Structural

2.0 USES

ViperStud studs and tracks are used for framing of interior nonload-bearing composite walls.

3.0 DESCRIPTION
3.1 General:

Products recognized under this report are limited to the ViperStud studs and tracks noted in Table 2. The studs are

roll-formed in a “C” shape with a rib (ViperRib) in the flange, an offset (planking) in the web and knurling on the flanges. The tracks are channel-shaped with offsets (planking) in the web. The studs are manufactured with and without punch-outs. The overall dimensions for the punch-outs are:

MANUFACTURER	MEMBER DEPTH	
	1 ⁵ / ₈ " & 2 ¹ / ₂ "	3 ⁵ / ₈ ", 4" & 6"
Marino\Ware	0.75" x 1.75"	1.50" x 2.50"
CEMCO	0.75" x 2.00"	1.50" x 2.75"
Telling Industries	0.75" x 2.50"	1.50" x 2.50"

For SI: 1 inch = 25.4 mm.

Punch-outs are spaced 24 inches (610 mm) on center along the centerline of the member, with a minimum distance of 10 inches (254 mm) from the end of the member to the near edge of the punch-out, when provided. See Figure 1 for stud and track configurations. See Figure 2 for punch-out configurations. See Table 1 for manufacturing locations.

3.2 Material:

3.2.1 Steel: The Viper25 studs and tracks and Viper20 tracks are formed from coils of steel complying with ASTM A 1003-10 Nonstructural Grade 50 (NS50) steel. The Viper20 studs are formed from coils of steel complying with ASTM A 1003-10 Nonstructural Grade 57 (NS57) steel. The Viper 27mil, Viper 30mil and Viper 33mil studs and tracks are formed from coils of steel complying with ASTM A 1003-10 Nonstructural Grade 33 (NS33) steel. The uncoated minimum base-metal thickness is specified in Table 2. The coating is minimum G40, A40, AZ50, GF30, T1-25, or T2-100 in accordance with ASTM A 1003-10.

3.2.2 Gypsum Wallboard: Gypsum wallboard must be a minimum of 5/8 inch (15.9 mm) thick and Type X, complying with ASTM C 1396 and manufactured by one of the following companies: American Gypsum; CertainTeed; Georgia Pacific; Lafarge; National Gypsum; Temple-Inland; or USG.

3.2.3 Fasteners: Fasteners for attaching the gypsum wallboard to the studs and tracks must be No. 6, Type S, fine thread drywall bugle head screws conforming to ASTM C 1002.

4.0 DESIGN AND INSTALLATION
4.1 Design:

Allowable wall heights for interior nonload-bearing composite wall design are shown in Table 3.

*Revised December 2011

4.2 Installation:

Installation of ViperStud studs and tracks must be in accordance with the approved plans and this report. The approved plans must be available on the jobsite at all times during installation.

Attachment of studs to tracks is optional. The gypsum wallboard must be installed on both sides of the wall framing for the full wall height, with the long dimension of the gypsum wallboard parallel to the studs. Placement of joints in the gypsum sheathing must be in accordance with Sections 4.6.3 and 4.6.4 of GA-216 (Gypsum Association Application and Finishing of Gypsum Panel Products) or Section 7.5 of ASTM C 840.

Maximum spacing of fasteners fastening the gypsum wallboard to the studs and tracks must be as follows:

STUD SPACING	STUDS	TRACKS
12" o.c.	12" o.c.	16" o.c.
16" o.c.	12" o.c.	16" o.c.
24" o.c.	12" o.c.	12" o.c.

For SI: 1 inch = 25.4 mm.

5.0 CONDITIONS OF USE

The ViperStud studs and tracks described in this report comply with, or are suitable alternatives to what is specified in, those codes listed in Section 1.0 of this report, subject to the following conditions:

- 5.1 Installation must comply with the approved plans and this report. In the event of a conflict, this report governs.
- 5.2 The interior nonload-bearing wall assemblies are limited to interior installations where the superimposed axial load is zero pounds.
- 5.3 Design of the attachment of the wall to the surrounding structure is outside the scope of this report.
- 5.4 Installation of the gypsum wallboard must meet the requirements of ASTM C 840 or GA-216.

6.0 EVIDENCE SUBMITTED

Data in accordance with the ICC-ES Acceptance Criteria for Cold-formed Steel Framing Members—Interior Nonload-bearing Wall Assemblies (AC86), dated February 2010.

7.0 IDENTIFICATION

Each ViperStud stud and track covered by this report must have a legible label or stamp, at a maximum spacing of 96 inches (2438 mm) on center, indicating the member designation; manufacturer’s name or initials [MarinoWARE (M/W), California Expanded Metal Company (CEMCO) or Telling Industries, LLC (TI)]; the minimum yield strength in ksi (if other than 33 ksi); the coating designation (if other than G40); and the evaluation report number (ESR-2620).

TABLE 1—MANUFACTURING LOCATIONS

MarinoWARE South Plainfield, NJ 07080	California Expanded Metal Company Pittsburg, CA 94565
MarinoWARE Griffin, GA 30223	California Expanded Metal Company Denver, CO 80204
MarinoWARE East Chicago, IN 46312	Telling Industries, LLC Cambridge, OH 43725
MarinoWARE Pasadena, TX 77507	Telling Industries, LLC Osceola, AR 72370
California Expanded Metal Company City of Industry, CA 91746	Telling Industries, LLC Kingman, AZ 86401

TABLE 2—MEMBER THICKNESS

MEMBER	STUD DESIGNATION ¹	TRACK DESIGNATION ¹	MINIMUM BASE-METAL THICKNESS (in)	DESIGN THICKNESS (in)	MINIMUM YIELD STRENGTH (ksi)
Viper25	xxxVS125-15	xxxVT125-15	0.0147	0.0155	50
Viper20 (1.625 – 3.625) ²	xxxVS125-20	xxxVT125-20	0.0195	0.0205	57 (stud) 50 (track)
Viper20 (4.00 – 6.00) ²	xxxVS125-21	xxxVT125-21	0.0209	0.0220	57 (stud) 50 (track)
Viper 27mil	xxxVS125-27	xxxVT125-27	0.0269	0.0283	33
Viper 30mil	xxxVS125-30	xxxVT125-30	0.0296	0.0312	33
Viper 33mil	xxxVS125-33	xxxVT125-33	0.0329	0.0346	33

For SI: 1 inch = 25.4 mm, 1 ksi = 6.895 MPa.

¹xxx is the web size in 1/100 of an inch.

²Applicable range of depths, in inches, for the member.

TABLE 3—LIMITING HEIGHTS^{1,2,3,4}, (ft-in)

DEPTH (in)	STUD (DESIGNATION)	SPACING (in)	5 psf			7.5 psf			10 psf		
			L _{/120}	L _{/240}	L _{/360}	L _{/120}	L _{/240}	L _{/360}	L _{/120}	L _{/240}	L _{/360}
1 ⁵ / ₈	Viper25 (162VS125-15)	12	13-9	11-4	9-10	12-0	9-11	8-3	10-11	8-10	----
		16	12-6	10-4	8-8	10-11	8-10	----	9-11	7-11	----
		24	10-11	8-10	----	9-5	----	----	8-2	----	----
	Viper20 (162VS125-20)	12	14-3	11-3	9-10	12-5	9-10	8-5	11-3	8-10	----
		16	12-11	10-3	8-10	11-3	8-10	----	10-3	7-11	----
		24	11-3	8-10	----	9-10	----	----	8-10	----	----
	Viper 27mil (162VS125-27)	12	14-4	11-5	9-11	12-6	9-11	8-5	11-5	8-10	---
		16	13-0	10-4	8-10	11-5	8-10	---	10-4	7-10	----
		24	11-5	8-10	---	9-10	---	----	8-6	----	----
	Viper 30mil (162VS125-30)	12	14-7	11-6	10-0	12-9	10-0	8-6	11-7	8-11	---
		16	13-3	10-5	8-11	11-7	8-11	---	10-6	7-10	---
		24	11-7	8-11	---	10-1	---	---	8-10	---	---
	Viper 33mil (162VS125-33)	12	14-11	11-10	10-4	13-0	10-4	8-10	11-10	9-4	7-11
		16	13-6	10-9	9-4	11-10	9-4	7-11	10-9	8-4	---
		24	11-10	9-4	7-11	10-4	7-11	---	9-4	---	---
2 ¹ / ₂	Viper25 (250VS125-15)	12	17-3	14-5	12-9	15-0	12-7	11-1	13-8	11-6	10-1
		16	15-8	13-1	11-7	13-8	11-6	10-1	12-3	10-5	8-9
		24	13-8	11-6	10-1	11-6	10-0	8-2	10-0	8-8	---
	Viper20 (250VS125-20)	12	17-11	14-10	13-2	5-8	13-0	11-6	14-3	11-10	10-5
		16	16-4	13-6	12-0	14-3	11-10	10-5	12-11	10-9	9-4
		24	14-3	11-10	10-5	12-5	10-4	8-9	11-3	9-2	---
	Viper 27mil (250VS125-27)	12	8-3	14-5	12-8	15-11	12-8	11-0	14-4	11-6	10-0
		16	16-7	13-2	11-6	14-4	11-6	10-0	12-5	10-5	8-11
		24	14-4	11-6	10-0	11-9	10-0	8-6	10-2	8-11	---
	Viper 30mil (250VS125-30)	12	18-9	14-10	13-0	16-4	13-0	11-4	14-10	11-10	10-4
		16	17-0	13-6	11-10	14-10	11-10	10-4	13-6	10-9	9-3
		24	14-10	11-10	10-4	12-9	10-4	8-10	11-0	9-3	7-10
	Viper 33mil (250VS125-33)	12	19-4	15-4	13-5	16-10	13-5	11-8	15-4	12-2	10-8
		16	17-7	13-11	12-2	15-4	12-2	10-8	13-11	11-0	9-8
		24	15-4	12-2	10-8	13-5	10-8	9-2	12-0	9-8	8-2
3 ⁵ / ₈	Viper25 (362VS125-15)	12	20-10	17-3	15-2	18-2	15-1	13-3	15-10	13-9	12-0
		16	18-11	15-9	13-9	15-10	13-9	12-0	13-9	12-6	10-11
		24	15-10	13-9	12-0	12-11	12-0	10-6	11-3	10-11	9-6
	Viper20 (365VS125-20)	12	21-10	17-11	15-9	19-1	15-8	13-9	17-4	14-3	12-6
		16	19-10	16-4	14-4	17-4	14-3	12-6	15-4	12-11	11-4
		24	17-4	14-3	12-6	14-6	12-5	10-11	12-7	11-4	9-11
	Viper 27mil (362VS125-27)	12	22-9	18-1	15-10	19-11	15-10	13-10	17-7	14-4	12-6
		16	20-8	16-5	14-4	17-7	14-4	12-6	15-3	13-0	11-2
		24	17-7	14-4	12-5	14-4	12-6	10-8	12-5	11-2	---
	Viper 30mil (362VS125-30)	12	23-3	18-6	16-2	20-4	16-2	14-1	18-6	14-8	12-10
		16	21-2	16-9	14-8	18-6	14-8	12-10	16-4	13-4	11-6
		24	18-6	14-8	12-10	15-4	12-10	11-0	13-4	11-6	9-11
	Viper 33mil (362VS125-33)	12	23-10	18-11	16-6	20-10	16-6	14-5	18-11	15-0	13-1
		16	21-8	17-2	15-0	18-11	15-0	13-1	17-2	13-8	11-10
		24	18-11	15-0	13-1	16-6	13-1	11-4	14-4	11-10	10-3
4	Viper25 (400VS125-15)	12	22-1	18-3	16-3	19-3	15-11	14-2	16-8	14-6	12-11
		16	20-0	16-7	14-9	16-8	14-6	12-11	14-5	13-2	11-9
		24	16-8	14-6	12-11	13-7	12-8	11-3	11-9	11-6	10-1
	Viper20 (400VS125-20)	12	24-0	19-1	16-8	21-0	16-8	14-7	19-1	15-2	13-3
		16	21-10	17-4	15-2	19-1	15-2	13-3	17-4	13-9	12-0
		24	19-1	15-2	13-3	16-8	13-3	11-7	14-11	12-0	10-5
	Viper 27 (400VS125-27)	12	24-9	19-8	17-2	20-7	17-2	15-0	17-10	15-7	13-8
		16	21-10	17-11	15-7	17-10	15-7	13-8	15-5	14-2	12-4
		24	17-10	15-7	13-8	14-7	13-8	11-10	12-7	12-4	10-9
	Viper 30 (400VS125-30)	12	25-2	20-0	17-6	22-0	17-6	15-3	19-5	15-11	13-10
		16	22-11	18-2	15-11	19-5	15-11	13-10	16-10	14-5	12-7
		24	19-5	15-11	13-10	15-10	13-10	12-1	13-9	12-7	10-11
	Viper 33 (400VS125-33)	12	25-8	20-4	17-10	22-5	17-10	15-7	20-4	16-2	14-1
		16	23-4	18-6	16-2	20-4	16-2	14-1	18-4	14-8	12-10
		24	20-4	16-2	14-1	17-3	14-2	12-4	15-0	12-10	11-2

TABLE 3—LIMITING HEIGHTS^{1,2,3,4}, (ft-in) – Continued

DEPTH (in)	STUD (DESIGNATION)	SPACING (in)	5 psf			7.5 psf			10 psf		
			L ₁₂₀	L ₂₄₀	L ₃₆₀	L ₁₂₀	L ₂₄₀	L ₃₆₀	L ₁₂₀	L ₂₄₀	L ₃₆₀
6	Viper25 (600VS125-15)	12	24-8	23-9	21-1	22-3	20-9	18-5	20-0	18-10	16-9
		16	22-11	21-7	19-2	20-0	18-10	16-9	17-5	17-2	15-3
		24	20-0	18-10	16-9	16-5	16-5	14-8	14-2	14-2	13-0
	Viper20 (600VS125-20)	12	29-1	25-7	22-6	25-10	22-4	19-8	23-8	20-4	17-11
		16	26-9	23-3	20-6	23-8	20-4	17-11	21-9	18-6	16-3
		24	23-8	20-4	17-11	20-11	17-9	15-7	18-2	16-2	14-2
	Viper 27 (600VS125-27)	12	29-7	25-11	22-8	24-2	22-8	19-9	20-11	20-7	18-0
		16	25-7	23-6	20-7	20-11	20-7	18-0	18-1	18-1	16-4
		24	20-11	20-7	18-0	17-1	17-1	15-8	14-9	14-9	14-2
	Viper 30 (600VS125-30)	12	31-10	26-9	23-4	26-0	23-4	20-5	22-6	21-3	18-6
		16	27-7	24-3	21-3	22-6	21-3	18-6	19-6	19-3	16-10
		24	22-6	21-3	18-6	18-5	18-5	16-2	15-11	15-11	14-8
	Viper 33 (600VS125-33)	12	34-5	27-7	24-1	28-1	24-1	21-1	24-4	21-11	19-2
		16	29-10	25-1	21-11	24-4	21-11	19-2	21-1	19-11	17-5
		24	24-4	21-11	19-2	19-11	19-2	16-9	17-2	17-2	15-2

For SI: 1 inch = 25.4 mm, 1 psf = 47.88 Pa.

¹Sheathing, as specified in Section 3.2.2, must be attached to both faces of the wall for the full height of the wall with the long dimension parallel to the studs.

²Sheathing must be fastened to the studs with fasteners as specified in Section 3.2.3 at a maximum spacing of 12 inches o.c. Sheathing must be fastened to the tracks with the fasteners as specified in Section 3.2.3 at a maximum spacing of 12 inches on center for walls with studs spaced at 24 inches on center. Sheathing must be fastened to the tracks with the fasteners as specified in Section 3.2.3 at a maximum spacing of 16 inches on center for walls with studs spaced at 12 or 16 inches on center.

³Placement of joints in the gypsum sheathing must be in accordance with Sections 4.6.3 and 4.6.4 of GA-216 or Section 7.5 of ASTM C 840.

⁴End bearing must be a minimum of 1 inch.

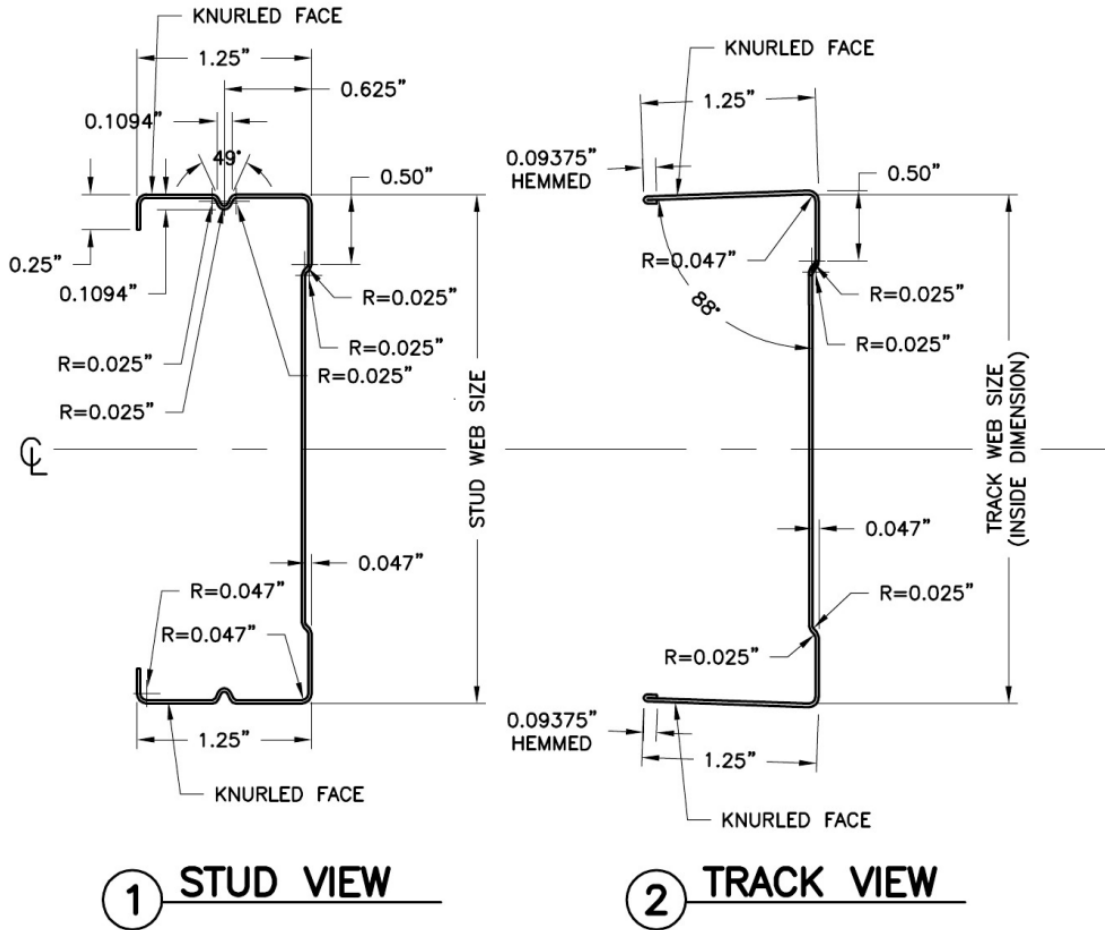

STUD WEB SIZES (OUTSIDE DIMENSIONS):

1⁵/₈", 2¹/₂", 3⁵/₈", 4" & 6"

TRACK WEB SIZES (INSIDE DIMENSIONS):

1⁵/₈", 2¹/₂", 3⁵/₈", 4" & 6"

The hemmed track flange is limited to xxxVT125-15 members.

FIGURE 1—STUD AND TRACK CONFIGURATION

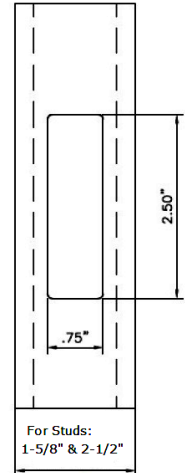
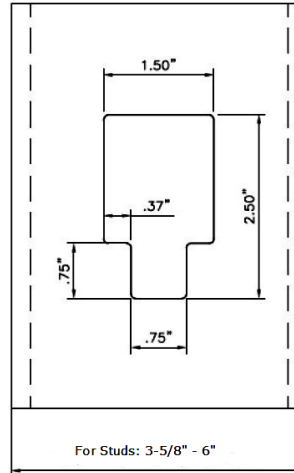
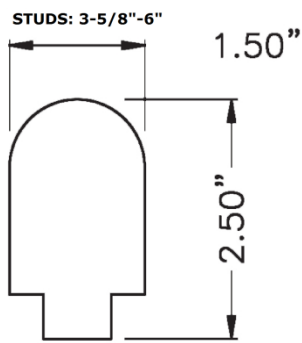
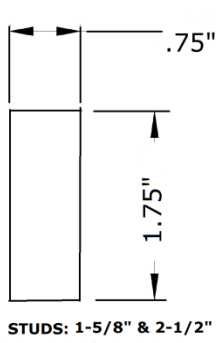

Marino\WARE

Telling Industries

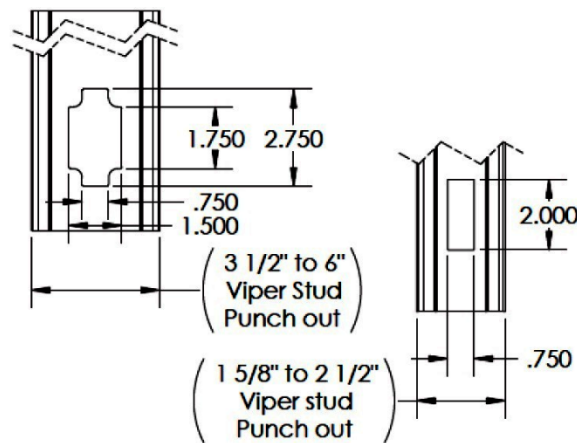

California Expanded Metal Company (CEMCO)

FIGURE 2—PUNCH-OUT CONFIGURATIONS

ICC-ES Evaluation Report**ESR-2620 FBC Supplement**

Issued January 1, 2012

This report is subject to renewal on July 1, 2013.

www.icc-es.org | (800) 423-6587 | (562) 699-0543

A Subsidiary of the International Code Council®

DIVISION: 05 00 00—METALS**Section: 05 40 00—Cold-Formed Metal Framing****DIVISION: 09 00 00—FINISHES****Section: 09 22 16.13—Non-Structural Metal Stud Framing****REPORT HOLDER:****WARE INDUSTRIES, INC. (DBA Marino\WARE)****400 METUCHEN ROAD****SOUTH PLAINFIELD, NEW JERSEY 07080****(908) 757-9000**www.marinoware.com**EVALUATION SUBJECT:****VIPERSTUD DRYWALL FRAMING SYSTEM (NONLOAD-BEARING): VIPER25, VIPER20, VIPER27MIL, VIPER 30MIL, VIPER 33MIL****1.0 EVALUATION SCOPE****Purpose:**

The purpose of this evaluation report supplement is to indicate that the ViperStud Drywall Framing System (Nonload-Bearing), recognized in ICC-ES master evaluation report ESR-2620, has also been evaluated for compliance with the codes noted below.

Applicable code editions:

- 2010 and 2007 *Florida Building Code—Building*
- 2010 and 2007 *Florida Building Code—Residential*

2.0 CONCLUSIONS

The ViperStud Drywall Framing System (Non-loadbearing), described in Sections 2.0 through 7.0 of the master report ESR-2620, complies with the 2010 and 2007 *Florida Building Code—Building* and the 2010 and 2007 *Florida Building Code—Residential*, provided the design and installation are in accordance with the *International Building Code* (IBC) provisions noted in the master report.

Use of the ViperStud Drywall Framing System (Nonload-bearing) has also been found to be in compliance with the High-Velocity Hurricane Zone provisions of the 2010 and 2007 *Florida Building Code—Building* and the 2010 and 2007 *Florida Building Code—Residential*.

For products falling under Florida Rule 9N-3, verification that the report holder's quality assurance program is audited by a quality assurance entity approved by the Florida Building Commission for the type of inspections being conducted is the responsibility of an approved validation entity (or the code official when the report holder does not possess an approval by the Commission).

This supplement expires concurrently with the master report reissued on July 1, 2011.