

FrameRite™ **Connectors**

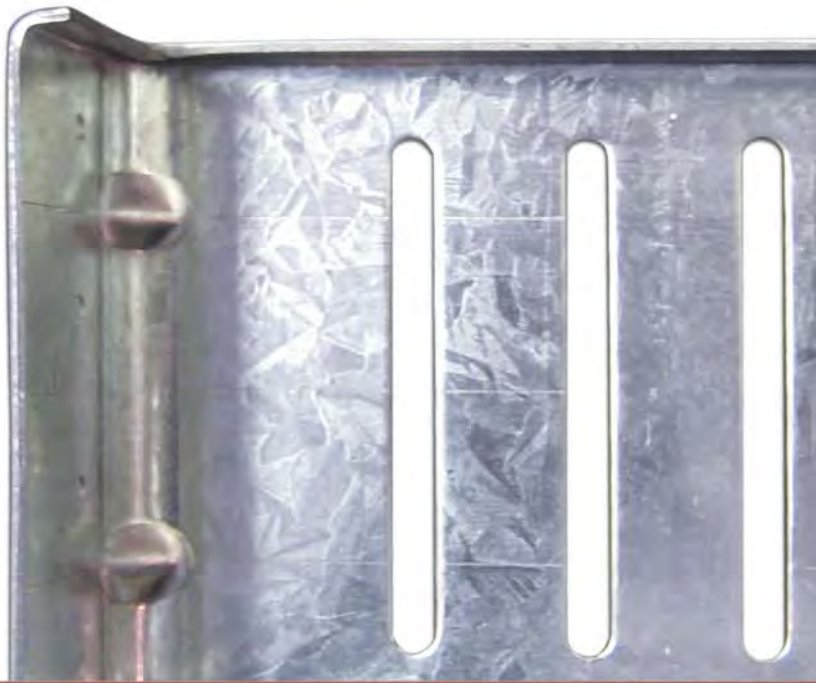

PRODUCT CATALOG

MARINO WARE®



THE BEST PRODUCTS, QUALITY, AND CUSTOMER SERVICE.

Our FrameRite Connectors Catalog details our line of high quality steel framing connectors. We know our customers depend on our quality products so we work hard to ensure each MarinoWARE product is manufactured and supplied using industry standards, backed by testing to assure reliability. Our connector line is another addition to our extensive family of steel framing products, with over 300 varieties of connectors to cover every requirement on the job.

Our large inventory of both finished product and coil steel allow us to readily satisfy your requests. Our fleet of trucks assures prompt deliveries and in many instances, next day delivery. Our experienced sales team, coupled with our large distribution network, make MarinoWARE® the obvious choice for any steel framing project.

For more information on our products and services, call 1-800-627-4661 or visit www.MarinoWARE.com.

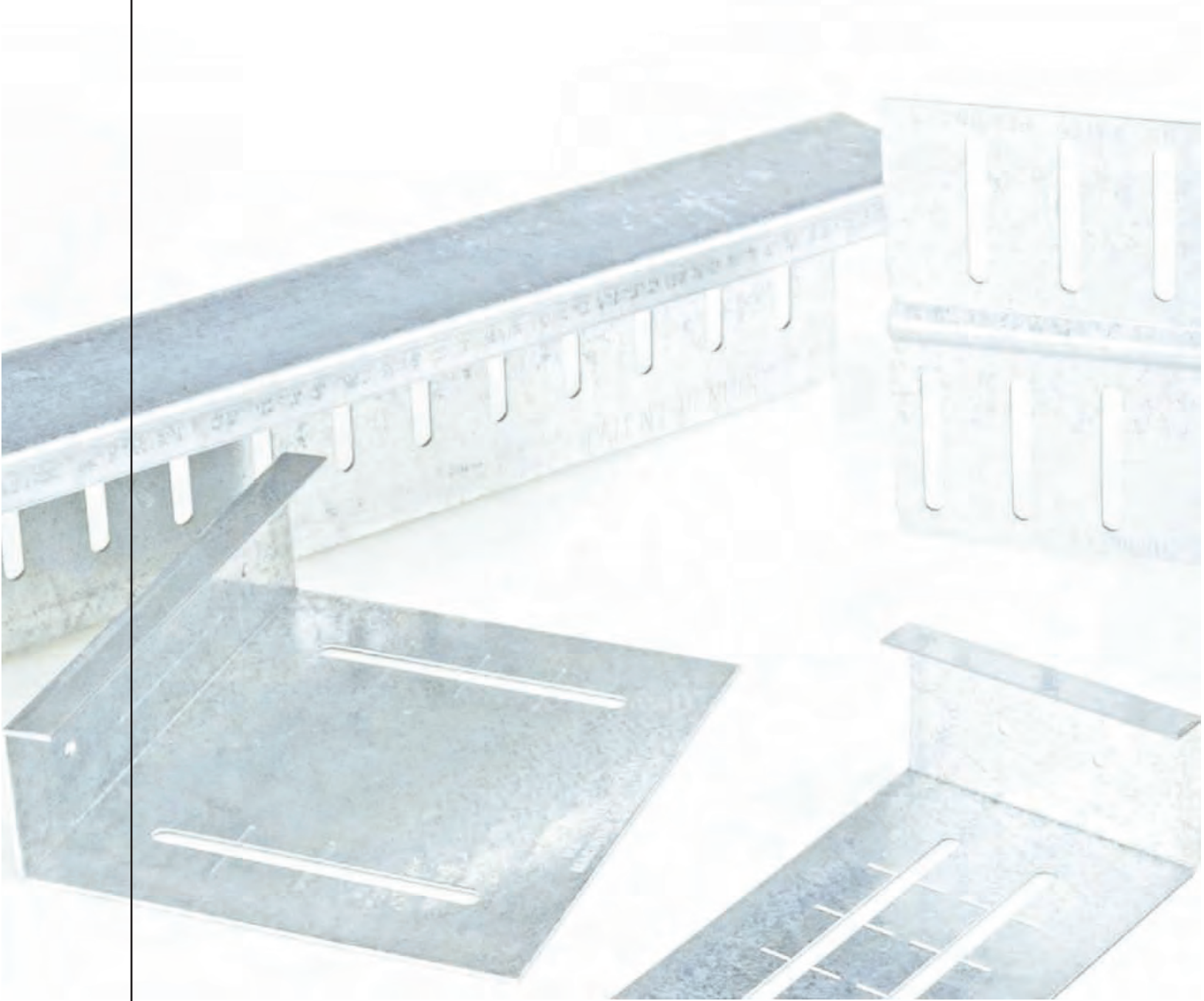

FrameRiteTM **Connectors**

Trusted by Architects and Builders throughout the country, MarinoWARE® has always been an industry leader in quality, service and new product development.

Our line of connectors are designed specifically to reduce labor while assuring proper attachment of cold formed steel products. In addition, we feature world-class Simpson Strong-Tie Connectors which are available through MarinoWARE®.

This combination of MarinoWARE® and Simpson Strong-Tie® Connectors unites two industry leaders and offers our customers a one-stop source for the most reliable connectors available. At MarinoWARE® we are dedicated to your success and committed to delivering the best possible products to the metal framing industry.

- FrameRite Connectors are the industry’s most comprehensive line of connectors for cold formed steel framing.
- Designed to significantly reduce time, labor, materials and costs, our connectors facilitate quicker, more cost-effective installation.
- Along with our partner Simpson Strong-Tie, the industry leader in connectors, we offer over 300 varieties of connectors covering every conceivable load requirement encountered on the jobsite.
- Save time, labor and cost. FrameRite Connectors give you more control, more options, and more ways to build better.

TECHNICAL SERVICES

MarinoWARE offers its customers free expert technical assistance with the selection and use of our FrameRite Connectors. If you have questions or need more information on any of the products listed in this catalog, contact our Technical Services department at 866-545-1545, or at connectors@marinoware.com and technicalservices@marinoware.com. In most cases Technical Services representatives can provide an immediate response.

DesignRiteTM

MarinoWARE offers professional Engineered Shop Drawings. These drawings are created using AutoCAD software and are prepared for the submittal process. In addition, these drawings assist the installer in the construction process indicating product gauge, spacing and connections. Most shop drawings can be completed within 2-3 weeks.

MarinoWARE, through the use of its talented employees and licensed professional consultants, is ready to assist you with your next project.

Our Engineering Group is located at 175 Country Club Drive, Suite 200A, Stockbridge, GA 30281. You can contact them at 866-545-1545 or engineering@marinoware.com.

For more information visit our website at www.MarinoWare.com

TABLE OF CONTENTS

DEFLECTION CONNECTORS	
WSC Slide Clips	2
Outrigger	3
WSC 950 & WSC 1500	4
Deflex Clip	5
DWSC Seismic Clip	5
Slotted Slip Track (SLT)	6, 7
Exterior Slotted Track (EXT)	8
RIGID CONNECTORS	
Utility Clip (UA) 16 Gauge	9
Utility Clip (UA) 14 Gauge	10
Utility Clip (UA) 12 Gauge	11
LA Clip (Large Utility Clip)	12
Utility Clip (UA & LA)	13
Rigid Clip Connector (RCC)	14
Rigid Clip Connector with HDW Washer	15
Holdown (S/HD & S/HDS)	16
Tension Tie (S/LTT & S/HTT)	16
WRC Rigid Clip	17
ROOF & TRUSS CONNECTORS	
Seismic & Hurricane Tie (S/H1A)	17
Seismic & Hurricane Tie (S/H)	18
Twist Strap (MTS)	18
Gusset Plate (Unpunched) (GP)	19
Strap Tie (ST/LSTA/MST/MSTA)	19
JOIST FRAMING CONNECTORS	
Solid Blocking (JB)	20
Web Stiffener (JS)	20
Reinforcing & Skewable Angle (LS)	21
Coiled Strap (CS)	21
S/LBV Hanger	22
S/BA Hanger	22
Ledger Connector System (ICFVL)	23
Framing Plate (LTP5)	23
Steel Joist Hanger (S/HJCT)	24
BRIDGING & BRACING CONNECTORS	
Bridgerite Clip (BR)	25
Coiled Strap (CS)	25
Katz Blocking (KB)	26
Tension Bridging (TB)	26
SPECIALTY PRODUCTS	
Breakaway Clip (BA)	27
Grommet	27
U-Flex Track	28
Resilmount Sound Isolation Clip	28

ALPHABETICAL PRODUCT INDEX

Breakaway Clip (BA)	27	Outrigger	3	Strap Tie (ST/LSTA/MST/MSTA)	19
Bridgerite Clip (BR)	25	Reinforcing & Skewable Angle (LS)	21	Tension Bridging (TB)	26
Coiled Strap (CS)	25	Resilmount Sound Isolation Clip NEW	28	Tension Tie (S/LTT & S/HTT)	16
Coiled Strap (CS)	21	Rigid Clip Connector (RCC)	14	Twist Strap (MTS)	18
Deflex Clip	5	Rigid Clip Connector with HDW Washer NEW	15	U-Flex Track	28
DWSC Seismic Clip NEW	5	S/BA Hanger NEW	22	Utility Clip (UA & LA)	13
Framing Plate (LTP5)	23	S/LBV Hanger	22	Utility Clip (UA) 12 Gauge	11
Grommet	27	Seismic & Hurricane Tie (S/H)	18	Utility Clip (UA) 14 Gauge	10
Gusset Plate (Unpunched) (GP)	19	Seismic & Hurricane Tie (S/H1A)	17	Utility Clip (UA) 16 Gauge	9
Holdown (S/HD & S/HDS)	16	Slotted Slip Track (Exterior) NEW	8	Web Stiffener (JS)	20
Katz Blocking (KB)	26	Slotted Slip Track (SLT)	6, 7	WRC Rigid Clip NEW	17
LA Clip (Large Utility Clip) NEW	12	Solid Blocking (JB)	20	WSC 950 & WSC 1500	4
Ledger Connector System (ICFVL)	23	Steel Joist Hanger (S/HJCT)	24	WSC Slide Clips NEW	2

WSC SLIDE CLIP

WSC Slide clips connect exterior curtainwall studs to the building structure and allow for vertical movement of the building independent of the studs. The new WSC series allows for 3" total deflection, 1-1/2" up and 1-1/2" down. WSC series 14 ga. clips come with extended leg lengths and shouldered screws are provided in each box of clips. 25 pieces per box.

MATERIAL: See Table

FINISH: Galvanized – G90

Part No.	Ga/Mil	Material	Finish	Size
WSC362	14ga (68)	50 KSI	G-90	4" x 1.5" x 3.5"
WSC600	14ga (68)	50 KSI	G-90	4" x 1.5" x 5.5"
WSC800	14ga (68)	50 KSI	G-90	4" x 1.5" x 7.5"
WSC1000	14ga (68)	50 KSI	G-90	4" x 1.5" x 9.5"
WSC1200	14ga (68)	50 KSI	G-90	4" x 1.5" x 11.5"

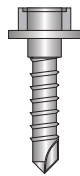
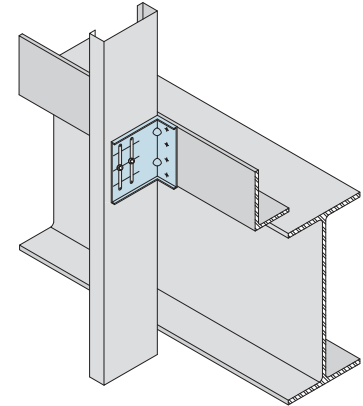
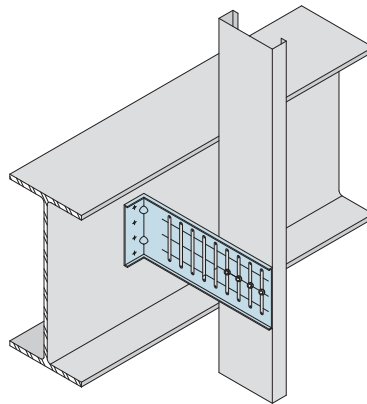

110 –#14 Shouldered screws included per box.

*(Note: WSC362 includes 55 - #14 shouldered screws per box)

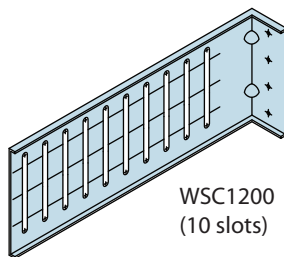

WSC1200
(10 slots)

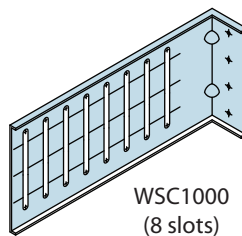

WSC1000
(8 slots)

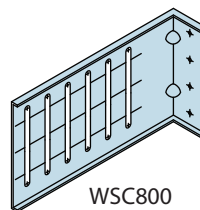

WSC800
(6 slots)

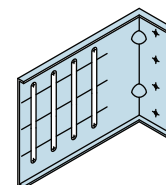

WSC600
(4 slots)

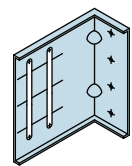

WSC362*
(2 slots)

CONCENTRIC TENSION (lbs.)

# Screws	CFS Member			
	33 mil	43 mil	54 mil	68 mil
2	376	560	652	652
3	564	840	978	978
4	752	1120	1304	1304
5	940	1400	1559	1559

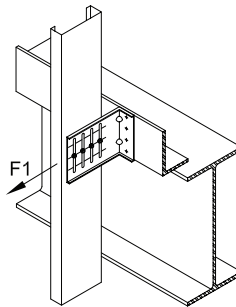

ECCENTRIC TENSION (lbs.)

# Screws	CFS Member			
	33 mil	43 mil	54 mil	68 mil
2	376	560	652	652
3	564	840	978	978
4	752	1120	1304	1304
5	940	1315	1315	1315

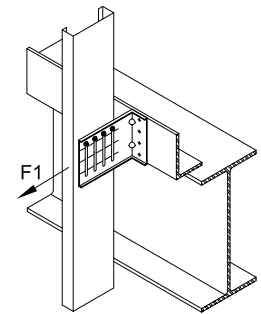

CONCENTRIC COMPRESSION (lbs.)

# Screws	CFS Member			
	33 mil	43 mil	54 mil	68 mil
2	376	560	652	652
3	564	840	966	966
4	752	966	966	966
5	940	966	966	966

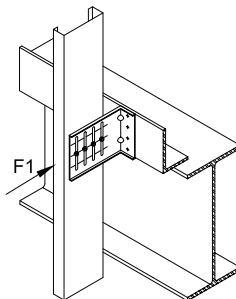

ECCENTRIC COMPRESSION (lbs.)

# Screws	CFS Member			
	33 mil	43 mil	54 mil	68 mil
2	376	560	652	652
3	564	788	788	788
4	752	788	788	788
5	788	788	788	788

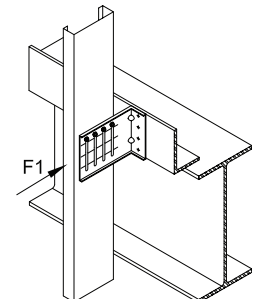

Deflection Connectors

Notes:

1. Allowable loads have not been increased for wind or seismic.
2. Attachment of WSC clip to main structure should be engineered by a design professional for steel or concrete base materials.
3. Allowable loads are based on attachment to main structure through pilot holes with #10-24 cap screws with a head diameter of 0.29".
4. Safety factor, Ω, determined in accordance with the provision of section F1.2 of the NASPEC with statistical data specified in AC208 and from test data.
5. The serviceability limit of 1/8" deflection between the stud and supporting structure did not govern in testing.
6. Eccentric tension and compression values represent clip capacity after structure deflects + 1-1/2" up or down from center of the clip.

OUTRIGGER

Outrigger Slide Clip is used for horizontal surface applications and offers the highest capacity of any horizontal surface connection clip. The outrigger comes in lengths of 18", can be field cut to shorter lengths if needed. Simple and fast to install which saves time and money. One clip fits all stud sizes, no right or left hand clips.

MATERIAL: 16 ga (54 mil) 50ksi.

FINISH: Galvanized – G90

DEFLECTION: 1-1/2" Total

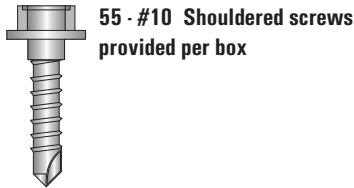

55 - #10 Shouldered screws provided per box

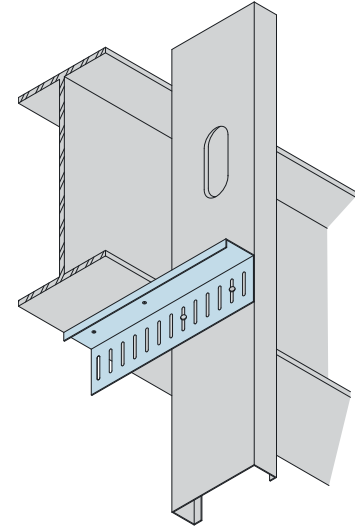
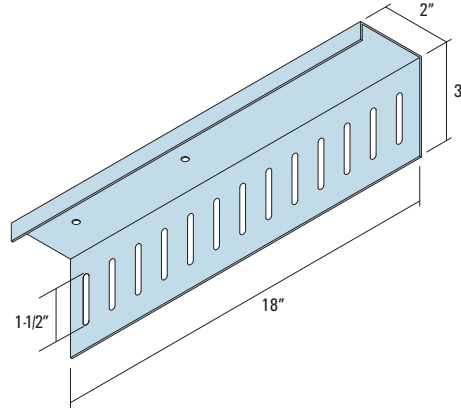

Model No.	Gauge (Mil) Yield	Box Quantity
Outrigger	16 (54) 50ksi	25

Connection to Structure Hilti 0.145" X-EDNI Powder Actuated Fastener in 3/16" Steel				Connection to Structure #12-14 Hilti kwik Pro Self Drilling Screws to 3/16" Steel			
Thickness (mil/ga)	No. of Screws	No. of Anchors	Allowable Load (lbs.)	Thickness (mils/ga)	No. of Screws	No. of Anchors	Allowable Load (lbs.)
20ga. (33 mil) 33ksi	2	2	278	20ga. (33 mil) 33ksi	2	2	278
		3	278			3	278
		4	278			4	278
20ga. (33 mil) 33ksi	4	2	484	20ga. (33 mil) 33ksi	4	2	557
		3	557			3	557
		4	557			4	557
18ga. (43 mil) 33ksi	2	2	413	18ga. (43 mil) 33ksi	2	2	413
		3	413			3	413
		4	413			4	413
18ga. (43 mil) 33ksi	4	2	483	18ga. (43 mil) 33ksi	4	2	590
		3	775			3	827
		4	827			4	827
16ga. (54 mil) 33ksi	2	2	483	16ga. (54 mil) 33ksi	2	2	580
		3	580			3	580
		4	580			4	580
16ga. (54 mil) 33ksi	4	2	483	16ga. (54 mil) 33ksi	4	2	590
		3	775			3	595
		4	910			4	1075
16ga. (54 mil) 50ksi	2	2	483	16ga. (54 mil) 50ksi	2	2	590
		3	740			3	742
		4	740			4	742
16ga. (54 mil) 50ksi	4	2	483	16ga. (54 mil) 50ksi	4	2	590
		3	775			3	985
		4	910			4	1075
14ga. (68 mil) 50ksi	2	2	483	14ga. (68 mil) 50ksi	2	2	590
		3	740			3	742
		4	740			4	742
14ga. (68 mil) 50ksi	4	2	783	14ga. (68 mil) 50ksi	4	2	590
		3	783			3	985
		4	910			4	1075

Notes:

1. All anchors must be attached in a single file line down the center of the clip.
2. All anchor data is from the Hilti 2006 Product Technical Guide.
3. All anchors must be attached to structure per manufacturer's instructions.
4. Anchor Spacing for 2 and 3 anchors to be min. 2".
5. Anchor Spacing for 4 anchors to be 1" min.
6. Anchor edge distance to be 1/2" min.

WSC 950 & WSC 1500

WSC 950 and 1500 Slide Clips provide lateral support for steel studs and allow for vertical movement of the building structure. They allow for 1-3/4" edge of slab tolerance from the existing supporting structure. The WSC Clips accommodate up to 3/4" vertical movement at intermediate floors and 1-1/2" vertical movement at roof levels. They are used in a vertical surface application. Simple and fast to install which saves time and money. One clip fits all stud sizes, no right or left hand clips. Screws must be backed out 1/4 turn once installed.

MATERIAL: See Table

FINISH: Galvanized – G90

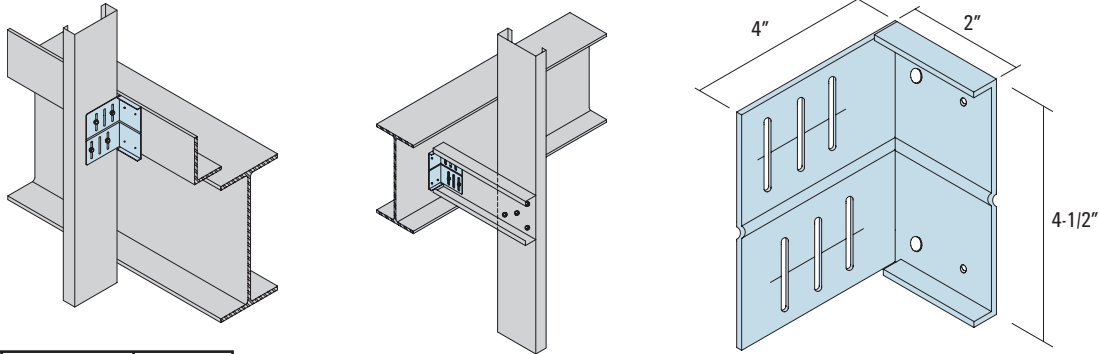

Model No.	Gauge (Mil) Yield	Box Quantity
WSC950	16 (54) 50ksi	25
WSC1500	12 (97) 40ksi	25

Screws not included for WSC1500 or WSC950

Connection to Structure Hilti 0.145" X-EDNI Powder Actuated Fastener in 3/16" Steel					Connection to Structure Hilti #12-14 Hilti Kwik Pro Self Drilling Screws to 3/16" Steel				
Stud Thickness	# of Screws to Stud	# of Anchors to Structure	WSC 950	WSC 1500	Stud Thickness	Number of Screws	Number of Anchors	WSC 950	WSC 1500
			Allowable Load (lbs.)	Allowable Load (lbs.)				Allowable Load (lbs.)	Allowable Load (lbs.)
20ga. (33 mil) 33ksi	4	2	220	220	20ga. (33 mil) 33ksi	4	2	500	555
		3	335	335			3	557	555
		4	445	445			4	557	555
20ga. (33 mil) 33ksi	6	2	220	220	20ga. (33 mil) 33ksi	6	2	500	770
		3	335	335			3	750	835
		4	445	445			4	835	835
18ga. (43 mil) 33ksi	4	2	220	220	18ga. (43 mil) 33ksi	4	2	500	770
		3	335	335			3	750	824
		4	445	445			4	827	824
18ga. (43 mil) 33ksi	6	2	220	220	18ga. (43 mil) 33ksi	6	2	500	770
		3	335	335			3	750	1150
		4	445	445			4	945	1240
16ga. (54 mil) 33ksi	4	2	220	220	16ga. (54 mil) 33ksi	4	2	500	770
		3	335	335			3	750	1150
		4	445	445			4	945	1480
16ga. (54 mil) 33ksi	6	2	220	220	16ga. (54 mil) 33ksi	6	2	500	770
		3	335	335			3	750	1150
		4	445	445			4	945	1480
16ga. (54 mil) 50ksi	4	2	220	220	16ga. (54 mil) 50ksi	4	2	500	770
		3	335	335			3	750	1150
		4	445	445			4	945	1480
16ga. (54 mil) 50ksi	6	2	220	220	16ga. (54 mil) 50ksi	6	2	500	770
		3	335	335			3	750	1150
		4	445	445			4	945	1495
14ga. (68 mil) 50ksi	4	2	220	220	14ga. (68 mil) 50ksi	4	2	500	770
		3	335	335			3	750	1150
		4	445	445			4	945	1480
14ga. (68 mil) 50ksi	6	2	220	220	14ga. (68 mil) 50ksi	6	2	500	770
		3	335	335			3	750	1150
		4	445	445			4	945	1495

Notes:

1. All anchors must be attached in a single file line down the center of the clip, do not use predrilled holes if attaching with PAF.
2. All anchor data is from the Hilti 2006 Product Technical Guide.
3. All anchors must be attached to structure per manufacturer's instructions.
4. All manufacturer's guidelines must be followed for anchor spacing and edge distance.

DEFLEX CLIP

The Deflex Slide Clips allow for up to 1-1/2" vertical floor or roof deflection without the use of laborious slip tracks it can be installed with or without standard leg tracks. Simple and fast to install which saves time and money. Two sizes available for 3-5/8", 4", 6" and 8" studs.

MATERIAL: 16 ga (54 mil) 50ksi.

FINISH: Galvanized – G90

- 3T1000 accommodates 3-5/8" and 4" stud widths
- 6T1000 accommodates 6" and 8" stud widths

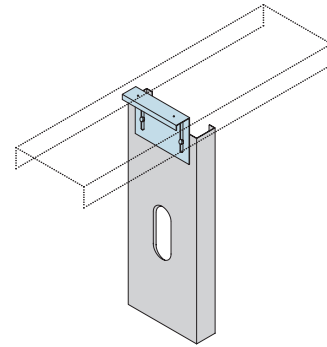
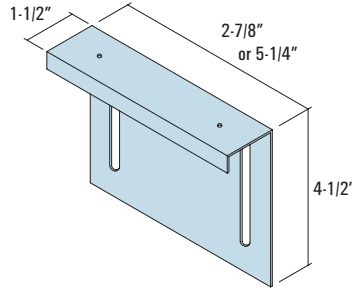

Model No.	Gauge (Mil) Yield	Box Quantity
3T1000	16 (54) 50 ksi	25
6T1000	16 (54) 50 ksi	25

Connection to Structure Hilti 0.145" X-EDNI Powder Actuated Fastener in 3/16" Steel					Connectin to Structure #12-14 Hilti Kwik Pro Self Drilling Screws to 3/16" Steel				
Stud Thickness	# of Screws to Stud	# of Anchors to Structure	Deflex 3T1000	Deflex 6T1000	Stud Thickness	Number of Screws	Number of Anchors	Deflex 3T1000	Deflex 6T1000
			Allowable Load (lbs.)	Allowable Load (lbs.)				Allowable Load (lbs.)	Allowable Load (lbs.)
20ga. (33 mil) 33ksi	2	2	224	276	20ga. (33 mil) 33ksi	2	2	278	278
		3	228	276				278	278
18ga. (43 mil) 33ksi	2	2	224	413	18ga. (43 mil) 33ksi	2	2	410	413
		3	228	413				410	413
16ga. (54 mil) 33ksi	2	2	224	413	16ga. (54 mil) 33ksi	2	2	455	580
		3	228	440				495	580
16ga. (54 mil) 50ksi	2	2	224	413	16ga. (54 mil) 50ksi	2	2	455	685
		3	228	440				495	742
14ga. (68 mil) 50ksi	2	2	224	413	14ga. (68 mil) 50ksi	2	2	455	685
		3	228	440				495	742

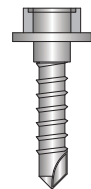

55 - #10 Shouldered screws included

Notes:

1. All anchors must be attached in a single file line down the center of the clip.
2. All anchor data is from the Hilti 2006 Product Technical Guide.
3. All anchors must be attached to structure per manufacturer's instructions.
4. Anchor edge distance to be 1/2" min.

DWSC SEISMIC CLIP

NEW

The DWSC series of clips allow for vertical and lateral movement of the building structure independent of the studs. The DWSC has a total of 3" vertical deflection and total of 2" lateral movement and uses shouldered screws which are included for ease of installation. 25 pieces per box.

Part No.	Ga/Mil	Material	Finish	Size
DWSC362	14ga (68)	50 KSI	G-90	4" x 2.5" x 3.5"
DWSC600	14ga (68)	50 KSI	G-90	4" x 2.5" x 5.5"
DWSC800	14ga (68)	50 KSI	G-90	4" x 2.5" x 7.5"
DWSC1000	14ga (68)	50 KSI	G-90	4" x 2.5" x 9.5"
DWSC1200	14ga (68)	50 KSI	G-90	4" x 2.5" x 11.5"

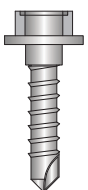
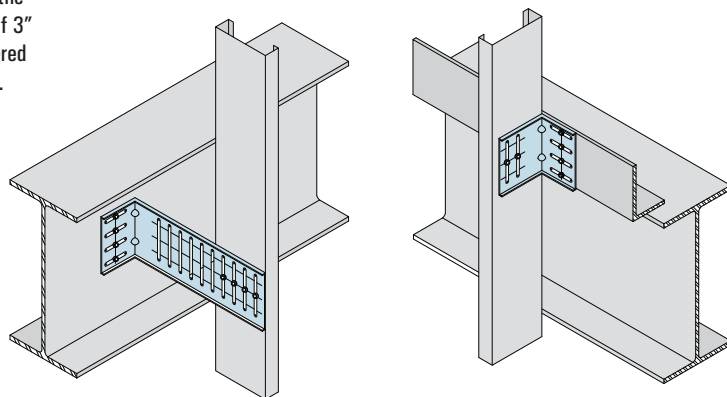

110 - #14 Shouldered screws included per box.

*(Note: DWSC362 includes 55 - #14 shouldered screws per box)

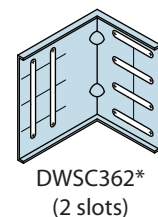
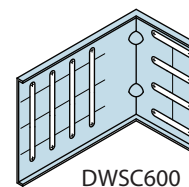
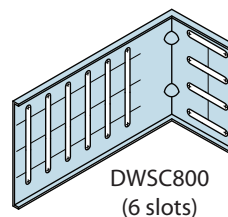
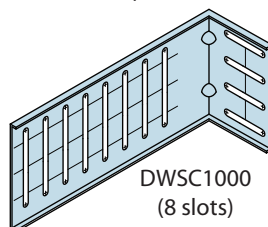
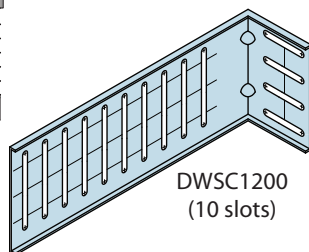

DEFLECTION CONNECTORS

SLOTTED SLIP TRACK (SLT)



Steel Framing and Metal Lath

Slotted Track manufactured by CEMCO and distributed by Marino|WARE is used at the head of wall and can absorb up to 1" of total vertical movement while providing a positive attachment for wall framing. The positive attachment allows for greater load resistance with thinner gauges of material. Slotted track is formed from only prime steel conforming to applicable ASTM requirements

MATERIAL: 20ga (33 mil-33ksi), 18ga (43 mil-33ksi), 16ga (54 mil- 50ksi), 14ga (68 mil - 50ksi)

WEB SIZES: 2-1/2", 3-5/8", 4", 6", 8"

FINISH: G60-18ga & 16ga, G40-20ga

- One-piece design
- Positive attachment to framing
- Absorbs vertical deflection
- Simple Installation and Reduced Labor Time

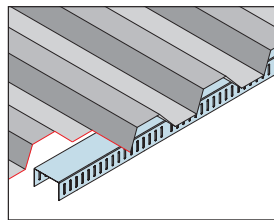
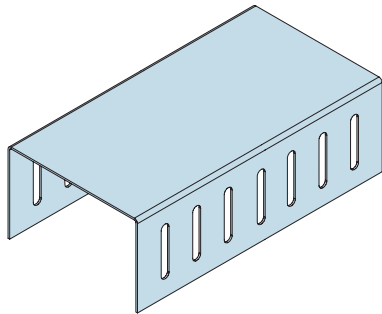

Model No.	Section Designation	Mil/Ga	Track Member Width	Flange
212SLT1410	250CST250-68	68 (14 ga)	2-1/2"	2-1/2"
212SLT2010	250CST250-30	33 (20 ga)	2-1/2"	2-1/2"
358SLT1410	362CST250-68	68 (14 ga)	3-5/8"	2-1/2"
358SLT1610	362CST250-54	54 (16 ga)	3-5/8"	2-1/2"
358SLT1810	362CST250-43	43 (18 ga)	3-5/8"	2-1/2"
358SLT2010	362CST250-30	33 (20 ga)	3-5/8"	2-1/2"
400SLT1410	400CST250-68	68 (14 ga)	4"	2-1/2"
400SLT1610	400CST250-54	54 (16 ga)	4"	2-1/2"
400SLT1810	400CST250-43	43 (18 ga)	4"	2-1/2"
400SLT2010	400CST250-30	33 (20 ga)	4"	2-1/2"
600SLT1410	600CST250-68	68 (14 ga)	6"	2-1/2"
600SLT1610	600CST250-54	54 (16 ga)	6"	2-1/2"
600SLT1810	600CST250-43	43 (18 ga)	6"	2-1/2"
600SLT2010	600CST250-33	33 (20 ga)	6"	2-1/2"
800SLT1410	800CST250-68	68 (14 ga)	8"	2-1/2"
800SLT1610	800CST250-54	54 (16 ga)	8"	2-1/2"
800SLT1810	800CST250-43	43 (18 ga)	8"	2-1/2"
800SLT2010	800CST250-33	33 (20 ga)	8"	2-1/2"

Model No.	Design Thickness (in.)	Gross Section Properties							Effective Section Properties					
		F _y (ksi)	Weight (lbs/ft)	Area (in ²)	I _x (in ⁴)	r _x (in)	I _y (in ⁴)	r _y (in ⁴)	I _x (in ⁴)	S _x (t) (in ³)	S _x (b) (in ³)	I _y (in ⁴)	S _y (l) (in ³)	S _y (r) (in ³)
250CST250-30	0.0312	33	0.444	0.131	0.112	0.925	0.133	1.011	0.098	0.126	0.056	0.099	0.096	0.063
250CST250-43	0.0451	33	0.64	0.188	0.16	0.923	0.193	1.012	0.148	0.212	0.082	0.147	0.136	0.096
250CST250-54	0.0566	50	0.802	0.236	0.2	0.922	0.243	1.015	0.186	0.266	0.103	0.186	0.169	0.121
350CST250-30	0.0312	33	0.549	0.162	0.12	0.861	0.293	1.346	0.105	0.156	0.057	0.214	0.15	0.099
350CST250-43	0.0451	33	0.793	0.233	0.172	0.859	0.424	1.348	0.160	0.271	0.084	0.334	0.216	0.161
350CST250-54	0.0566	50	0.994	0.292	0.215	0.857	0.533	1.351	0.201	0.340	0.105	0.421	0.269	0.202
362CST250-30	0.0312	33	0.562	0.165	0.121	0.853	0.318	1.387	0.105	0.158	0.057	0.232	0.158	0.103
362CST250-43	0.0451	33	0.812	0.239	0.173	0.851	0.461	1.389	0.161	0.279	0.084	0.362	0.226	0.168
362CST250-54	0.0566	50	1.018	0.300	0.216	0.85	0.58	1.391	0.202	0.349	0.105	0.456	0.283	0.212
362CST250-68	0.0713	50	1.2826	0.3773	0.2762	0.8556	0.7265	1.3875	0.2648	0.4717	0.1366	0.5879	0.3536	0.2789
400CST250-30	0.0312	33	0.602	0.177	0.123	0.832	0.403	1.508	0.106	0.162	0.058	0.334	0.182	0.148
400CST250-43	0.0451	33	0.87	0.256	0.176	0.83	0.584	1.511	0.165	0.300	0.084	0.483	0.262	0.212
400CST250-54	0.0566	50	1.090	0.321	0.22	0.829	0.734	1.512	0.206	0.375	0.106	0.607	0.327	0.265
400CST250-68	0.0713	50	1.3737	0.4041	0.2815	0.8346	0.92	1.5089	0.2697	0.5061	0.1371	0.7508	0.4079	0.3258
600CST250-33	0.0346	33	0.903	0.266	0.145	0.738	1.212	2.136	0.123	0.209	0.064	0.973	0.364	0.284
600CST250-43	0.0451	33	1.176	0.346	0.188	0.737	1.581	2.137	0.170	0.342	0.085	1.365	0.481	0.416
600CST250-54	0.0566	50	1.475	0.434	0.235	0.735	1.985	2.139	0.213	0.431	0.106	1.713	0.601	0.52
600CST250-68	0.0713	50	1.8584	0.5467	0.301	0.742	2.4937	2.1358	0.2856	0.6473	0.1387	2.1377	0.7524	0.6469
800CST250-33	0.0346	33	1.138	0.335	0.15	0.669	2.521	2.744	0.124	0.215	0.065	1.792	0.557	0.367
800CST250-43	0.0451	33	1.483	0.436	0.195	0.668	3.286	2.745	0.172	0.362	0.085	2.688	0.742	0.597
800CST250-54	0.0566	50	1.860	0.547	0.243	0.666	4.124	2.746	0.216	0.457	0.107	3.415	0.931	0.763
800CST250-68	0.0713	50	2.3238	0.6836	0.304	0.6667	5.095	2.73	0.2839	0.7125	0.1351	4.5031	1.1714	1.047

Deflection Connectors

SLOTTED SLIP TRACK (SLT) CONTINUED



Steel Framing and Metal Lath

APPROVALS

- **ICC-ES Approval**
ESR-2012 – 1 and 2 hour designs – UL 2079 Standard Compliant
- **UL Approval**
UL Approved Systems – Fire Stop Manufacturer and Design Number
UL Control (US) – R25033 – 1 and 2 hour designs – UL 2079 standard compliant
UL Control (CD) – R25033 – 1 and 2 hour designs – UL 2079 standard compliant
- **FireStik**
HW-D-0420 HW-D-0421 HW-D-0453 HW-D-0455 HW-D-0461 HW-D-0462 HW-D-0463 HW-D-0475
HW-D-0476 HW-D-0475 HW-D-0476 HW-D-0477 HW-D-0480 – 1" deflection shaft wall
- **Rectorseal**
HW-D-0032 HW-D-0033 HW-D-0058 HW-D-0059 HW-D-0104 HW-D-0105 HW-D-0127 HW-D-0128 HW-D-0129
HW-D-0130 HW-D-0179 HW-D-0180 HW-D-0221 HW-D-0222 HW-D-0297 HW-D-0298 HW-D-0380 HW-D-0381
- **Specified Technologies Inc. (STI)**
HW-D-0003 HW-D-0034 HW-D-0043 HW-D-0044 HW-D-0054 HW-D-0079 HW-D-0088 HW-D-0099 HW-D-0102
HW-D-0103 HW-D-0136 HW-D-0137 HW-D-0152 HW-D-0153 HW-D-0194 HW-D-0210 HW-D-0241 HW-D-0242
HW-D-0243 HW-D-0252 HW-D-0260 HW-D-0363 HW-D-0365 HW-D-0371 HW-D-0377 HW-D-0456 HW-D-0457
- **HILTI**
HW-D-0042 HW-D-0045 HW-D-0046 HW-D-0049 HW-D-0076 HW-D-0077 HW-D-0082 HW-D-0083 HW-D-0084
HW-D-0085 HW-D-0087 HW-D-0089 HW-D-0106 HW-D-0154 HW-D-0184 HW-D-0190 HW-D-0209 HW-D-0218
HW-D-0259 HW-D-0264 HW-D-0292 HW-D-0295 HW-D-0313 HW-D-0321 HW-D-0322 HW-D-0324 HW-D-0342
HW-D-0388 HW-D-0396
- **Passive Fire Protection Partners (PFPP)**
HW-D-0036
- **EGS Nelson Firestop**
HW-D-0223 HW-D-0224 HW-D-0227 HW-D-0228 HW-D-0238 HW-D-0239 HW-D-0283 HW-D-0288 HW-D-0304
HW-D-0305 HW-D-0309 HW-D-0310 HW-D-0393
- **A/D Systems**
HW-D-0247 HW-D-0249 HW-D-0314 HW-D-0315 HW-D-0316 HW-D-0317 HW-D-0320
- **Intertek/Warlock Hersey Approved Systems**
DESIGN NO. CEM/PV 120-01 – FIRESTIK
DESIGN NO. CEM/PV 120-02 – FIRESTIK
DESIGN NO. CEM/PV 120-03 – MONOKOTE, ISOLATEK, CAFCO 300
DESIGN NO. CEM/PV 120-04 – MONOKOTE, ISOLATEK, CAFCO 300

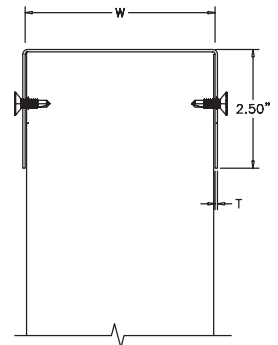
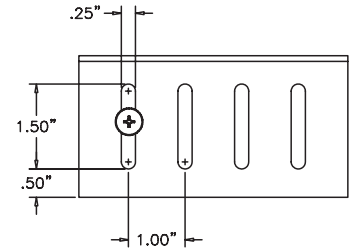

UNENCUMBERED ASSEMBLIES (See the Slotted Slip Track technical data sheet at www.MarinoWARE.com for more assemblies.)

Head of Wall System 4
1/2" Allowable Vertical Movements
2 HR. Fire Resistant Assembly

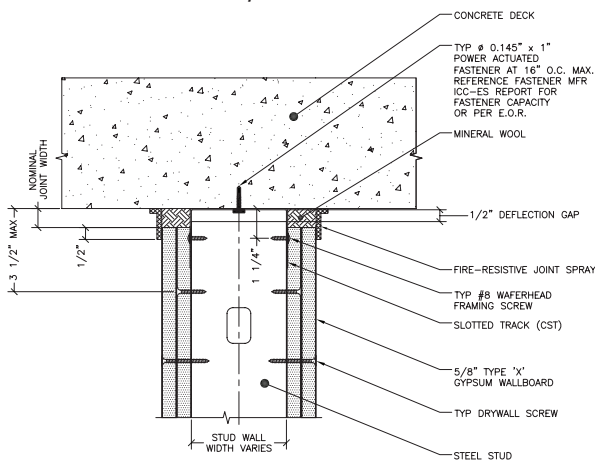

Notes:

1. Cyclical Design – UL 2079 Test Standard
2. Do not screw drywall to slotted track
3. Reference ITS/Warlock Hersey directory for specific information
4. Reference UL Fire Resistance Directory for specific information

Head of Wall System 4 Perpendicular to Flute Detail
1/2" Allowable Vertical Movements
2 HR. Fire Resistant Assembly

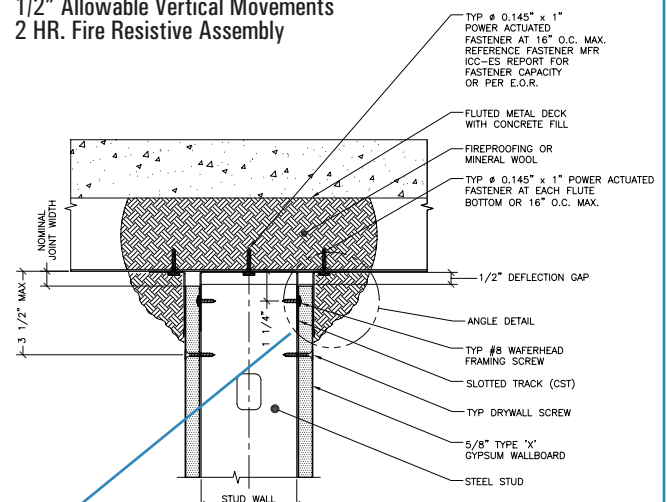

Notes:

1. Cyclical Design – UL 2079 Test Standard
2. Do not screw drywall to slotted track
3. Reference ITS/Warlock Hersey directory for specific information
4. Reference UL Fire Resistance Directory for specific information

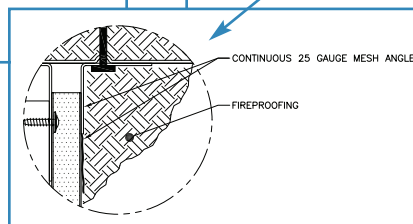

EXTERIOR SLOTTED TRACK (EXT)

NEW



Steel Framing and Metal Lath

CEMCO Exterior Slotted Track (EXT) is a vertical deflection track member. The external groove provides a resting point for sheathing, transferring the weight of the sheathing to the framing member, and the 2" web slots provide drift movement capabilities. The section is fabricated from hot-dipped galvanized steel complying with ASTM A653, and ASTM A1003 Structural Grade 50 Type H for 50 ksi yield strength steel and Grade 33 Type H for 33 ksi yield strength steel with a minimum G40 coating.

MATERIAL: 20ga (33 mil-33ksi), 18ga (43 mil-33ksi), 16ga (54 mil- 50ksi), 14ga (68 mil - 50ksi)

WEB SIZES: 3-5/8", 4", 6", and 8"

FINISH: G60-18ga & 16ga, G40-20ga

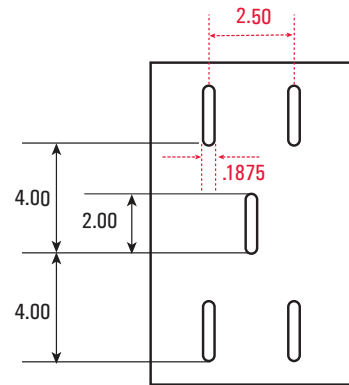
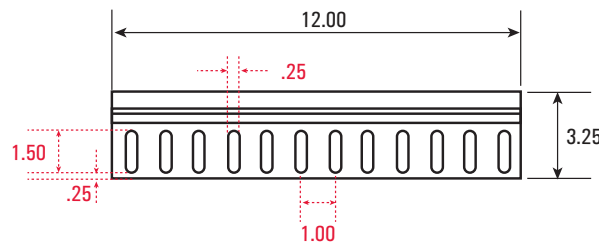
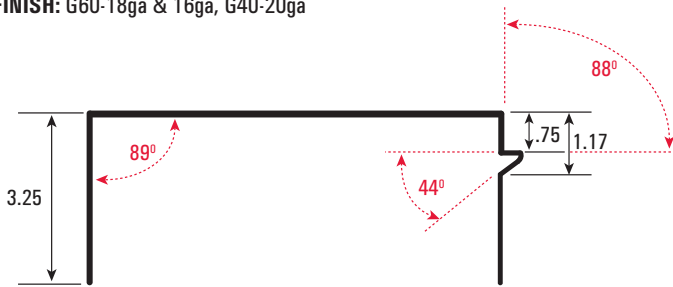
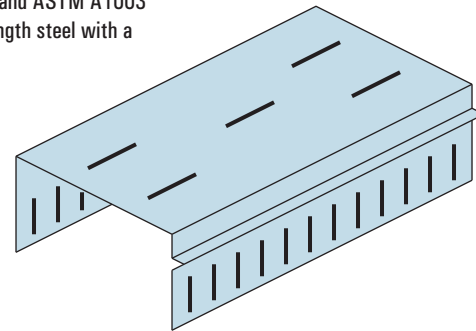

Model No.	Design Thickness (in.)	Full Section Properties							Effective Section Properties					
		F _y (ksi)	Weight (lbs/ft)	Area (in ²)	I _x (in ⁴)	r _x (in)	I _y (in ⁴)	r _y (in ⁴)	I _x (in ⁴)	S _{x(t)} (in ³)	S _{x(b)} (in ³)	I _y (in ⁴)	S _{y(l)} (in ³)	S _{y(r)} (in ³)
362EXT325-33	0.0346	33	1.2266	0.3608	0.3986	1.0512	0.9569	1.6286	0.1616	0.2584	0.0615	0.542	0.2924	0.2486
362EXT325-43	0.0451	33	1.5866	0.4666	0.5128	1.0483	1.2241	1.6197	0.2155	0.3708	0.0808	0.6938	0.3733	0.3226
362EXT325-54	0.0566	33	1.9743	0.5807	0.6345	1.0453	1.5048	1.6098	0.2665	0.4582	0.0999	0.8545	0.4587	0.403
362EXT325-54	0.0566	50	1.9743	0.5807	0.6345	1.0453	1.5048	1.6098	0.2665	0.4582	0.0999	0.8453	0.4596	0.3944
362EXT325-68	0.0713	50	2.4599	0.7235	0.7847	1.0414	1.8458	1.5972	0.3296	0.5659	0.1235	1.0364	0.5641	0.4911
400EXT325-33	0.0346	33	1.2678	0.3729	0.4108	1.0496	1.1616	1.765	0.1607	0.2547	0.0614	0.6688	0.2837	0.2837
400EXT325-43	0.0451	33	1.6403	0.4824	0.5285	1.0467	1.4875	1.7559	0.2171	0.3792	0.0811	0.8597	0.4217	0.3705
400EXT325-54	0.0566	33	2.0417	0.6005	0.654	1.0436	1.8306	1.746	0.2723	0.4907	0.101	1.0586	0.5189	0.4618
400EXT325-54	0.0566	50	2.0417	0.6005	0.654	1.0436	1.8306	1.746	0.2684	0.4685	0.1003	1.0493	0.5198	0.4535
400EXT325-68	0.0713	50	2.5448	0.7485	0.8091	1.0397	2.2487	1.7333	0.3367	0.606	0.1249	1.2868	0.6388	0.5636
600EXT325-33	0.0346	33	1.5093	0.4439	0.4686	1.0274	2.845	2.5316	0.1532	0.2235	0.0598	1.693	0.573	0.4862
600EXT325-43	0.0451	33	1.955	0.575	0.6032	1.0242	3.6572	2.522	0.2127	0.3559	0.0808	2.2388	0.7376	0.663
600EXT325-54	0.0566	33	2.4367	0.7167	0.7467	1.0207	4.5201	2.5114	0.2784	0.5284	0.1022	2.7978	0.9138	0.8418
600EXT325-54	0.0566	50	2.4367	0.7167	0.7467	1.0207	4.5201	2.5114	0.2651	0.4507	0.0996	2.7559	0.9128	0.8188
600EXT325-68	0.0713	50	3.0424	0.8948	0.924	1.0164	5.583	2.4978	0.3468	0.6707	0.1269	3.4291	1.1306	1.0337
800EXT325-33	0.0346	33	1.7473	0.5139	0.5099	0.9961	5.4182	3.2471	0.1546	0.2289	0.06	3.1772	0.8539	0.6704
800EXT325-43	0.0451	33	2.2652	0.6663	0.6565	0.9926	6.9799	3.2367	0.2155	0.3704	0.0807	4.2347	1.1025	0.9218
800EXT325-54	0.0566	33	2.826	0.9312	0.813	0.9889	8.647	3.2254	0.2835	0.5638	0.1032	5.4137	1.3712	1.2139
800EXT325-54	0.0566	50	2.826	0.9312	0.813	0.9889	8.647	3.2254	0.2687	0.4702	0.1003	5.2263	1.3664	1.1403
800EXT325-68	0.0713	50	3.5328	1.0391	1.006	0.9841	10.712	3.2108	0.3535	0.7184	0.1282	6.6816	1.7007	1.5032

Notes:

Full section properties analysis based on shapes without holes. Effective section properties analysis based on shapes with holes in each leg and top web.

UTILITY CLIP (UA) - 16 GAUGE

Utility Clips are used in a variety of framing applications including floors, walls and roofs. UA clips are pre-cut with pre-drilled holes for easy installation.

- Leg lengths available from 3-1/4" through 15-3/4". (See table for exact sizes)
- Leg widths available in 1-1/2", 2", 3" and 4".
- Available in 16, 14 and 12 gauge.
- Pre-punched for faster and more accurate fastener attachment.
- 3" x 3" Clips available (do not have embossments) See page 12

MATERIAL: See Table for sizes – 50ksi

FINISH: Galvanized – G90

INSTALLATION:

- Utility Clips are attached to the cold formed steel (CFS) framing members using #10 - 16 self-drilling screws; using pre-punched holes.

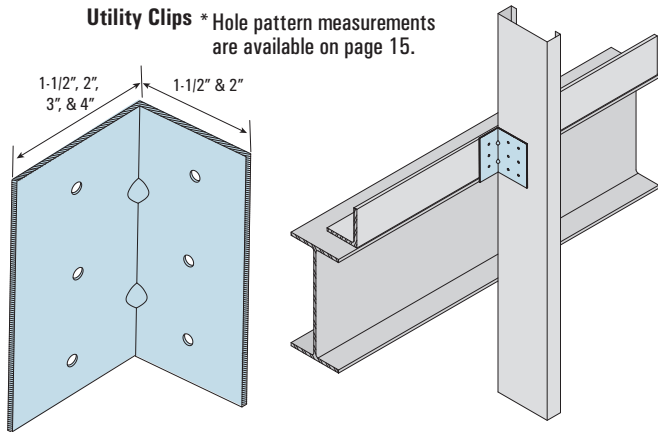

UA Clips - 16 Gauge					Allowable Load (lbs)											
Model No.	Thickness (mil/ga)	Size (in.)	Box Qty	Screws	20ga (33 mil) 33 ksi		18ga (43 mil) 33 ksi		16ga (54 mil) 33 ksi		16ga (54 mil) 50 ksi		14ga (68 mil) 50 ksi		12ga (97 mil) 50 ksi	
					F1	F2	F1	F2	F1	F2	F1	F2	F1	F2	F1	F2
UA-113-16	54 (16 ga)	1-1/2 x 1-1/2 x 3-1/4	100	3-#10	686	380	907	462	907	546	1313	546	1589	644	1589	644
UA-223-16	54 (16 ga)	2 x 2 x 3-1/4	100	3-#10	686	380	907	462	907	546	1313	546	1589	644	1589	644
UA-133-16	54 (16 ga)	1-1/2 x 3 x 3-1/4	100	3-#10	562	380	562	462	562	546	722	546	722	644	722	644
UA-143-16	54 (16 ga)	1-1/2 x 4 x 3-1/4	100	3-#10	495	380	489	462	489	546	489	546	489	644	489	644
UA-115-16	54 (16 ga)	1-1/2 x 1-1/2 x 5-1/4	100	3-#10	686	435	907	645	907	882	1313	882	1589	1040	1589	1040
UA-225-16	54 (16 ga)	2 x 2 x 5-1/4	50	3-#10	686	435	907	645	907	882	1313	882	1589	1040	1589	1040
UA-135-16	54 (16 ga)	1-1/2 x 3 x 5-1/4	50	3-#10	562	435	562	645	562	882	722	882	722	1040	722	1040
UA-145-16	54 (16 ga)	1-1/2 x 4 x 5-1/4	50	3-#10	495	435	489	645	489	882	489	882	489	1040	489	1040
UA-118-16	54 (16 ga)	1-1/2 x 1-1/2 x 7-3/4	50	5-#10	1143	725	1512	1075	1512	1302	2188	1302	2649	1535	2649	1535
UA-228-16	54 (16 ga)	2 x 2 x 7-3/4	50	5-#10	1143	725	1512	1075	1512	1302	2188	1302	2649	1535	2649	1535
UA-138-16	54 (16 ga)	1-1/2 x 3 x 7-3/4	25	5-#10	1143	725	1512	1075	1512	1302	2188	1302	2562	1535	2562	1535
UA-148-16	54 (16 ga)	1-1/2 x 4 x 7-3/4	25	5-#10	1143	725	1468	1075	1468	1302	1468	1302	1468	1535	1468	1535
UA-119-16	54 (16 ga)	1-1/2 x 1-1/2 x 9	50	5-#10	1143	725	1512	1075	1512	1512	2188	1512	2649	1782	2649	1782
UA-229-16	54 (16 ga)	2 x 2 x 9	50	5-#10	1143	725	1512	1075	1512	1512	2188	1512	2649	1782	2649	1782
UA-139-16	54 (16 ga)	1-1/2 x 3 x 9	25	5-#10	1143	725	1512	1075	1512	1512	2188	1512	2562	1782	2562	1782
UA-149-16	54 (16 ga)	1-1/2 x 4 x 9	25	5-#10	1143	725	1512	1075	1512	1512	2188	1512	2377	1782	2377	1782
UA-1110-16	54 (16 ga)	1-1/2 x 1-1/2 x 9-3/4	50	5-#10	1143	725	1512	1075	1512	1515	2188	1638	2649	1795	2649	1795
UA-2210-16	54 (16 ga)	2 x 2 x 9-3/4	50	5-#10	1143	725	1512	1075	1512	1515	2188	1638	2649	1795	2649	1795
UA-1310-16	54 (16 ga)	1-1/2 x 3 x 9-3/4	25	5-#10	1143	725	1512	1075	1512	1515	2188	1638	2562	1795	2562	1795
UA-1410-16	54 (16 ga)	1-1/2 x 4 x 9-3/4	25	5-#10	1143	725	1512	1075	1512	1515	2188	1638	2377	1795	2377	1795
UA-1112-16	54 (16 ga)	1-1/2 x 1-1/2 x 11-3/4	50	7-#10	1600	1015	2116	1505	2116	1974	3063	1974	3709	2327	3709	2327
UA-2212-16	54 (16 ga)	2 x 2 x 11-3/4	50	7-#10	1600	1015	2116	1505	2116	1974	3063	1974	3709	2327	3709	2327
UA-1312-16	54 (16 ga)	1-1/2 x 3 x 11-3/4	25	7-#10	1600	1015	2116	1505	2116	1974	3063	1974	3586	2327	3586	2327
UA-1412-16	54 (16 ga)	1-1/2 x 4 x 11-3/4	25	7-#10	1600	1015	2116	1505	2116	1974	3063	1974	3328	2327	3328	2327
UA-1114-16	54 (16 ga)	1-1/2 x 1-1/2 x 13-3/4	50	9-#10	2057	1305	2721	1935	2721	2310	3938	2310	4768	2723	4768	2723
UA-2214-16	54 (16 ga)	2 x 2 x 13-3/4	50	9-#10	2057	1305	2721	1935	2721	2310	3938	2310	4768	2723	4768	2723
UA-1314-16	54 (16 ga)	1-1/2 x 3 x 13-3/4	25	9-#10	2057	1305	2721	1935	2721	2310	3938	2310	4611	2723	4611	3231
UA-1414-16	54 (16 ga)	1-1/2 x 4 x 13-3/4	25	9-#10	2057	1305	2721	1935	2721	2310	3938	2310	4279	2723	4279	3231
UA-1116-16	54 (16 ga)	1-1/2 x 1-1/2 x 15-3/4	50	9-#10	2057	1305	2721	1935	2721	2646	3938	2646	4768	3119	4768	3119
UA-2216-16	54 (16 ga)	2 x 2 x 15-3/4	25	9-#10	2057	1305	2721	1935	2721	2646	3938	2646	4768	3119	4768	3119
UA-1316-16	54 (16 ga)	1-1/2 x 3 x 15-3/4	25	9-#10	2057	1305	2721	1935	2721	2646	3938	2646	4611	3119	4611	3119
UA-1416-16	54 (16 ga)	1-1/2 x 4 x 15-3/4	25	9-#10	2057	1305	2721	1935	2721	2646	3938	2646	4279	3119	4279	3119

Notes:

1. Allowable loads have not been increased for wind or seismic.
2. Allowable strength shown is the lowest value from the four failure modes: screw tilting/hearing, screw shear, screw pull-over and the serviceability limit state of 1/8" deflection of CFS members.
3. It is the responsibility of design professional to design the connection of UA connectors to the supporting structure. In the test program, this connection was made with cap screws with a head diameter of 0.29". The allowable loads should be conservative for any fastener with a header diameter equal to or greater than 0.29".
4. F1 = Shear, F2 = Tension

RIGID CONNECTORS

UTILITY CLIP (UA) - 14 GAUGE

Utility Clips are used in a variety of framing applications including floors, walls and roofs. UA clips are pre-cut with pre-drilled holes for easy installation.

- Leg lengths available from 3-1/4" through 15-3/4". (See table for exact sizes)
- Leg widths available in 1-1/2", 2", 3" and 4".
- Available in 16, 14 and 12 gauge.
- Pre-punched for faster and more accurate fastener attachment.
- 3" x 3" Clips available (do not have embossments) See page 12

MATERIAL: See Table for sizes – 50ksi

FINISH: Galvanized – G90

INSTALLATION:

- Utility Clips are attached to the cold formed steel (CFS) framing members using #10 - 16 self-drilling screws; using pre-punched holes.

Utility Clips

* Hole pattern measurements are available on page 15.

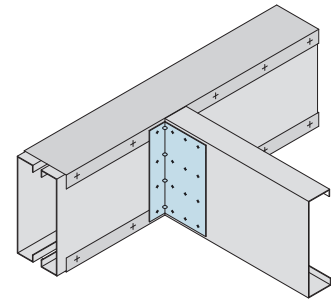
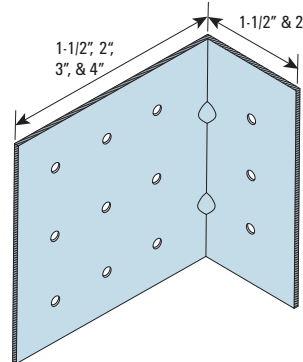

UA Clips - 14 Gauge					Allowable Load (lbs)											
Model No.	Thickness (mil/ga)	Size (in.)	Box Qty	Screws	20ga (33 mil) 33 ksi		18ga (43 mil) 33 ksi		16ga (54 mil) 33 ksi		16ga (54 mil) 50 ksi		14ga (68 mil) 50 ksi		12ga (97 mil) 50 ksi	
					F1	F2	F1	F2	F1	F2	F1	F2	F1	F2	F1	F2
UA-113-14	68 (14 ga)	1-1/2 x 1-1/2 x 3-1/4	100	3-#10	686	435	907	645	907	861	1313	861	1589	920	1589	920
UA-223-14	68 (14 ga)	2 x 2 x 3-1/4	100	3-#10	686	435	907	645	907	861	1313	861	1589	920	1589	920
UA-133-14	68 (14 ga)	1-1/2 x 3 x 3-1/4	100	3-#10	562	435	562	645	562	861	722	861	722	920	722	920
UA-143-14	68 (14 ga)	1-1/2 x 4 x 3-1/4	100	3-#10	495	435	489	645	489	861	489	861	489	920	489	920
UA-115-14	68 (14 ga)	1-1/2 x 1-1/2 x 5-1/4	100	3-#10	686	435	907	645	907	909	1313	1290	1589	1290	1589	1290
UA-225-14	68 (14 ga)	2 x 2 x 5-1/4	50	3-#10	686	435	907	645	907	909	1313	1290	1589	1290	1589	1290
UA-135-14	68 (14 ga)	1-1/2 x 3 x 5-1/4	50	3-#10	562	435	562	645	562	909	722	1290	722	1290	722	1290
UA-145-14	68 (14 ga)	1-1/2 x 4 x 5-1/4	50	3-#10	495	435	489	645	489	909	489	1290	489	1290	489	1290
UA-118-14	68 (14 ga)	1-1/2 x 1-1/2 x 7-3/4	50	5-#10	1143	725	1512	1075	1512	1515	2188	2054	2649	2150	2649	2150
UA-228-14	68 (14 ga)	2 x 2 x 7-3/4	50	5-#10	1143	725	1512	1075	1512	1515	2188	2054	2649	2150	2649	2150
UA-138-14	68 (14 ga)	1-1/2 x 3 x 7-3/4	25	5-#10	1143	725	1512	1075	1512	1515	2188	2054	2562	2150	2562	2150
UA-148-14	68 (14 ga)	1-1/2 x 4 x 7-3/4	25	5-#10	1143	725	1468	1075	1468	1515	1468	2054	1468	2150	1468	2150
UA-119-14	68 (14 ga)	1-1/2 x 1-1/2 x 9	50	5-#10	1143	725	1512	1075	1512	1515	2188	2150	2649	2150	2649	2150
UA-229-14	68 (14 ga)	2 x 2 x 9	50	5-#10	1143	725	1512	1075	1512	1515	2188	2150	2649	2150	2649	2150
UA-139-14	68 (14 ga)	1-1/2 x 3 x 9	25	5-#10	1143	725	1512	1075	1512	1515	2188	2150	2562	2150	2562	2150
UA-149-14	68 (14 ga)	1-1/2 x 4 x 9	25	5-#10	1143	725	1512	1075	1512	1515	2188	2150	2377	2150	2377	2150
UA-1110-14	68 (14 ga)	1-1/2 x 1-1/2 x 9-3/4	50	5-#10	1143	725	1512	1075	1512	1515	2188	2150	2649	2150	2649	2150
UA-2210-14	68 (14 ga)	2 x 2 x 9-3/4	50	5-#10	1143	725	1512	1075	1512	1515	2188	2150	2649	2150	2649	2150
UA-1310-14	68 (14 ga)	1-1/2 x 3 x 9-3/4	25	5-#10	1143	725	1512	1075	1512	1515	2188	2150	2562	2150	2562	2150
UA-1410-14	68 (14 ga)	1-1/2 x 4 x 9-3/4	25	5-#10	1143	725	1512	1075	1512	1515	2188	2150	2377	2150	2377	2150
UA-1112-14	68 (14 ga)	1-1/2 x 1-1/2 x 11-3/4	50	7-#10	1600	1015	2116	1505	2116	2121	3063	3010	3709	3010	3709	3010
UA-2212-14	68 (14 ga)	2 x 2 x 11-3/4	50	7-#10	1600	1015	2116	1505	2116	2121	3063	3010	3709	3010	3709	3010
UA-1312-14	68 (14 ga)	1-1/2 x 3 x 11-3/4	25	7-#10	1600	1015	2116	1505	2116	2121	3063	3010	3586	3010	3586	3010
UA-1412-14	68 (14 ga)	1-1/2 x 4 x 11-3/4	25	7-#10	1600	1015	2116	1505	2116	2121	3063	3010	3328	3010	3328	3010
UA-1114-14	68 (14 ga)	1-1/2 x 11/2 x 13-3/4	50	9-#10	2057	1305	2721	1935	2721	2727	3938	3644	4768	3870	4768	3870
UA-2214-14	68 (14 ga)	2 x 2 x 13-3/4	50	9-#10	2057	1305	2721	1935	2721	2727	3938	3644	4768	3870	4768	3870
UA-1314-14	68 (14 ga)	1-1/2 x 3 x 13-3/4	25	9-#10	2057	1305	2721	1935	2721	2727	3938	3644	4611	3870	4611	3870
UA-1414-14	68 (14 ga)	1-1/2 x 4 x 13-3/4	25	9-#10	2057	1305	2721	1935	2721	2727	3938	3644	4279	3870	4279	3870
UA-1116-14	68 (14 ga)	1-1/2 x 1-1/2 x 15-3/4	50	9-#10	2057	1305	2721	1935	2721	2727	3938	3870	4768	3870	4768	3870
UA-2216-14	68 (14 ga)	2 x 2 x 15-3/4	25	9-#10	2057	1305	2721	1935	2721	2727	3938	3870	4768	3870	4768	3870
UA-1316-14	68 (14 ga)	1-1/2 x 3 x 15-3/4	25	9-#10	2057	1305	2721	1935	2721	2727	3938	3870	4611	3870	4611	3870
UA-1416-14	68 (14 ga)	1-1/2 x 4 x 15-3/4	25	9-#10	2057	1305	2721	1935	2721	2727	3938	3870	4279	3870	4279	3870

Notes:

1. Allowable loads have not been increased for wind or seismic.
2. Allowable strength shown is the lowest value from the four failure modes: screw tilting/bearing, screw shear, screw pull-over and the serviceability limit state of 1/8" deflection of CFS members.
3. It is the responsibility of design professional to design the connection of UA connectors to the supporting structure. In the test program, this connection was made with cap screws with a head diameter of 0.29". The allowable loads should be conservative for any fastener with a head diameter equal to or greater than 0.29".
4. F1 = Shear, F2 = Tension

UTILITY CLIP (UA) - 12 GAUGE

Utility Clips are used in a variety of framing applications including floors, walls and roofs. UA clips are pre-cut with pre-drilled holes for easy installation.

- Leg lengths available from 3-1/4" through 15-3/4". (See table for exact sizes)
- Leg widths available in 1-1/2", 2", 3" and 4".
- Available in 16, 14 and 12 gauge.
- Pre-punched for faster and more accurate fastener attachment.
- 3"x 3" Clips available (do not have embossments) See page 12

MATERIAL: See Table for sizes – 50ksi

FINISH: Galvanized – G90

INSTALLATION:

- Utility Clips are attached to the cold formed steel (CFS) framing members using #10 - 16 self-drilling screws; using pre-punched holes.

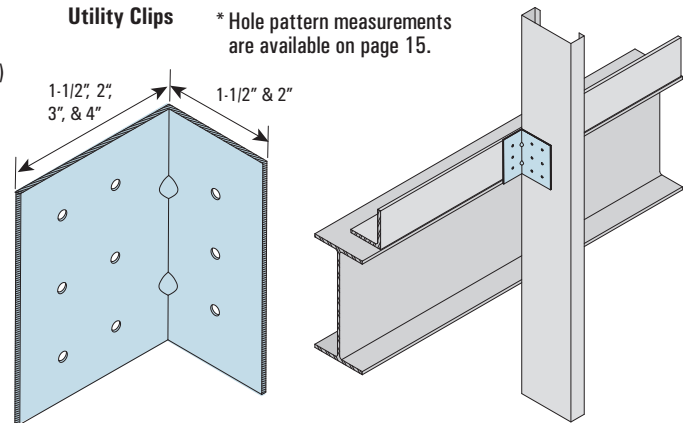

UA Clips - 12 Gauge					Allowable Load (lbs)											
Model No.	Thickness (mil/ga)	Size (in.)	Box Qty	Screws	20ga (33 mil) 33 ksi		18ga (43 mil) 33 ksi		16ga (54 mil) 33 ksi		16ga (54 mil) 50 ksi		14ga (68 mil) 50 ksi		12ga (97 mil) 50 ksi	
					F1	F2	F1	F2	F1	F2	F1	F2	F1	F2	F1	F2
UA-113-12	97 (12 ga)	1-1/2 x 1-1/2 x 3-1/4	100	3-#10	686	435	907	645	907	909	1313	1290	1589	1290	1589	1290
UA-223-12	97 (12 ga)	2 x 2 x 3-1/4	100	3-#10	686	435	907	645	907	909	1313	1290	1589	1290	1589	1290
UA-133-12	97 (12 ga)	1-1/2 x 3 x 3-1/4	100	3-#10	686	435	907	645	907	909	1313	1290	1537	1290	1537	1290
UA-143-12	97 (12 ga)	1-1/2 x 4 x 3-1/4	50	3-#10	686	435	907	645	907	909	1313	1290	1426	1290	1426	1290
UA-115-12	97 (12 ga)	1-1/2 x 1-1/2 x 5-1/4	100	3-#10	686	435	907	645	907	909	1313	1290	1589	1290	1589	1290
UA-225-12	97 (12 ga)	2 x 2 x 5-1/4	50	3-#10	686	435	907	645	907	909	1313	1290	1589	1290	1589	1290
UA-135-12	97 (12 ga)	1-1/2 x 3 x 5-1/4	50	3-#10	686	435	907	645	907	909	1313	1290	1537	1290	1537	1290
UA-145-12	97 (12 ga)	1-1/2 x 4 x 5-1/4	50	3-#10	686	435	907	645	907	909	1313	1290	1426	1290	1426	1290
UA-118-12	97 (12 ga)	1-1/2 x 1-1/2 x 7-3/4	50	5-#10	1143	725	1512	1075	1512	1515	2188	2150	2649	2150	2649	2150
UA-228-12	97 (12 ga)	2 x 2 x 7-3/4	50	5-#10	1143	725	1512	1075	1512	1515	2188	2150	2649	2150	2649	2150
UA-138-12	97 (12 ga)	1-1/2 x 3 x 7-3/4	25	5-#10	1143	725	1512	1075	1512	1515	2188	2150	2562	2150	2562	2150
UA-148-12	97 (12 ga)	1-1/2 x 4 x 7-3/4	25	5-#10	1143	725	1512	1075	1512	1515	2188	2150	2377	2150	2377	2150
UA-119-12	97 (12 ga)	1-1/2 x 1-1/2 x 9	50	5-#10	1143	725	1512	1075	1512	1515	2188	2150	2649	2150	2649	2150
UA-229-12	97 (12 ga)	2 x 2 x 9	25	5-#10	1143	725	1512	1075	1512	1515	2188	2150	2649	2150	2649	2150
UA-139-12	97 (12 ga)	1-1/2 x 3 x 9	25	5-#10	1143	725	1512	1075	1512	1515	2188	2150	2562	2150	2562	2150
UA-149-12	97 (12 ga)	1-1/2 x 4 x 9	25	5-#10	1143	725	1512	1075	1512	1515	2188	2150	2377	2150	2377	2150
UA-1110-12	97 (12 ga)	1-1/2 x 1-1/2 x 9-3/4	50	5-#10	1143	725	1512	1075	1512	1515	2188	2150	2649	2150	2649	2150
UA-2210-12	97 (12 ga)	2 x 2 x 9-3/4	25	5-#10	1143	725	1512	1075	1512	1515	2188	2150	2649	2150	2649	2150
UA-1310-12	97 (12 ga)	1-1/2 x 3 x 9-3/4	25	5-#10	1143	725	1512	1075	1512	1515	2188	2150	2562	2150	2562	2150
UA-1410-12	97 (12 ga)	1-1/2 x 4 x 9-3/4	25	5-#10	1143	725	1512	1075	1512	1515	2188	2150	2377	2150	2377	2150
UA-1112-12	97 (12 ga)	1-1/2 x 1-1/2 x 1-13/4	25	7-#10	1600	1015	2116	1505	2116	2121	3063	3010	3709	3010	3709	3010
UA-2212-12	97 (12 ga)	2 x 2 x 11-3/4	25	7-#10	1600	1015	2116	1505	2116	2121	3063	3010	3709	3010	3709	3010
UA-1312-12	97 (12 ga)	1-1/2 x 3 x 11-3/4	25	7-#10	1600	1015	2116	1505	2116	2121	3063	3010	3586	3010	3586	3010
UA-1412-12	97 (12 ga)	1-1/2 x 4 x 11-3/4	25	7-#10	1600	1015	2116	1505	2116	2121	3063	3010	3328	3010	3328	3010
UA-1114-12	97 (12 ga)	1-1/2 x 1-1/2 x 13-3/4	25	9-#10	2057	1305	2721	1935	2721	2727	3938	3870	4768	3870	4768	3870
UA-2214-12	97 (12 ga)	2 x 2 x 13-3/4	25	9-#10	2057	1305	2721	1935	2721	2727	3938	3870	4768	3870	4768	3870
UA-1314-12	97 (12 ga)	1-1/2 x 3 x 13-3/4	15	9-#10	2057	1305	2721	1935	2721	2727	3938	3870	4611	3870	4611	3870
UA-1414-12	97 (12 ga)	1-1/2 x 4 x 13-3/4	15	9-#10	2057	1305	2721	1935	2721	2727	3938	3870	4279	3870	4279	3870
UA-1116-12	97 (12 ga)	1-1/2 x 1-1/2 x 15-3/4	25	9-#10	2057	1305	2721	1935	2721	2727	3938	3870	4768	3870	4768	3870
UA-2216-12	97 (12 ga)	2 x 2 x 15-3/4	15	9-#10	2057	1305	2721	1935	2721	2727	3938	3870	4768	3870	4768	3870
UA-1316-12	97 (12 ga)	1-1/2 x 3 x 15-3/4	15	9-#10	2057	1305	2721	1935	2721	2727	3938	3870	4611	3870	4611	3870
UA-1416-12	97 (12 ga)	1-1/2 x 4 x 15-3/4	15	9-#10	2057	1305	2721	1935	2721	2727	3938	3870	4279	3870	4279	3870

Notes:

1. Allowable loads have not been increased for wind or seismic.
2. Allowable strength shown is the lowest value from the four failure modes: screw tilting/bearing, screw shear, screw pull-over and the serviceability limit state of 1/8" deflection of CFS members.
3. It is the responsibility of design professional to design the connection of UA connectors to the supporting structure. In the test program, this connection was made with cap screws with a head diameter of 0.29". The allowable loads should be conservative for any fastener with a header diameter equal to or greater than 0.29".
4. F1=Shear, F2=Tension

LA CLIP (LARGE UTILITY CLIP)

NEW

The LA series of clip angles is a series of rigid clips used in a variety of framing applications. Pre-drilled for ease of installation.

MATERIAL: See table for sizes – 50ksi

FINISH: Galvanized – G90

3" x 3" LA Clips

Model No.	Size (in.)	Box Qty
LA333-16	3 x 3 x 3-1/4	100
LA333-14	3 x 3 x 3-1/4	100
LA333-12	3 x 3 x 3-1/4	50
LA335-16	3 x 3 x 5-1/4	50
LA335-14	3 x 3 x 5-1/4	50
LA335-12	3 x 3 x 5-1/4	50
LA338-16	3 x 3 x 7-3/4	25
LA338-14	3 x 3 x 7-3/4	25
LA338-12	3 x 3 x 7-3/4	25

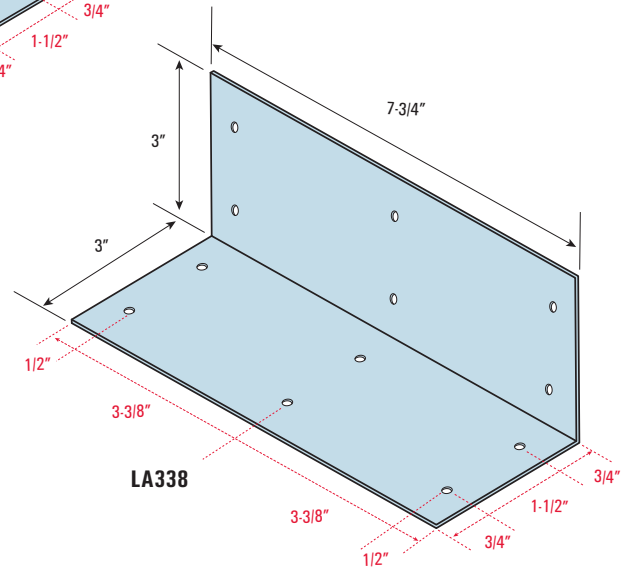
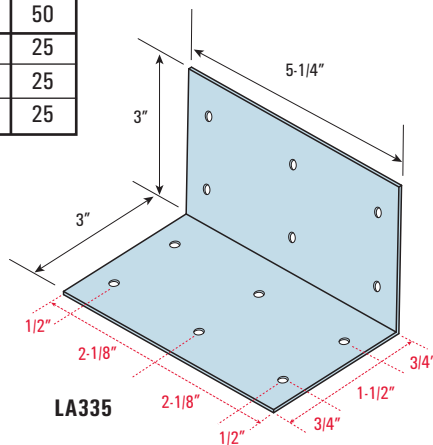
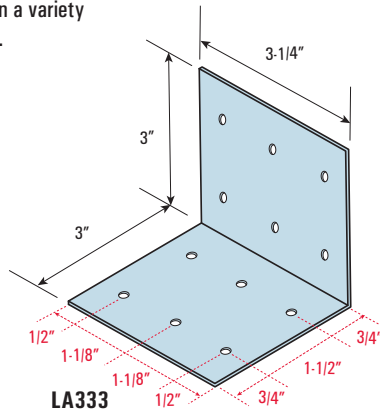

LA Clips				Allowable Load (lbs)											
Model No.	Thickness (mil/ga)	Size (in.)	Screws	20ga (33 mil) 33 ksi		18ga (43 mil) 33 ksi		16ga (54 mil) 33 ksi		16ga (54 mil) 50 ksi		14ga (68 mil) 50 ksi		12ga (97 mil) 50 ksi	
				Shear	Tension	Shear	Tension	Shear	Tension	Shear	Tension	Shear	Tension	Shear	Tension
LA-333-16	54 (16 GA)	3" x 3" x 3-1/4"	6 - #10	562	380	562	462	562	546	722	546	722	644	722	644
LA-333-14	68 (14 GA)	3" x 3" x 3-1/4"	6 - #10	562	602	562	689	562	861	722	861	722	920	722	920
LA-333-12	97 (12 GA)	3" x 3" x 3-1/4"	6 - #10	562	870	562	1160	562	1515	722	1515	722	1495	722	1495
LA-335-16	54 (16 GA)	3" x 3" x 5-1/4"	6 - #10	562	614	562	746	562	882	722	882	722	1040	722	1040
LA-335-14	68 (14 GA)	3" x 3" x 5-1/4"	6 - #10	562	870	562	1113	562	1391	722	1391	722	1486	722	1486
LA-335-12	97 (12 GA)	3" x 3" x 5-1/4"	6 - #10	562	870	562	1290	562	1818	722	2447	722	2415	722	2415
LA-338-16	54 (16 GA)	3" x 3" x 7-3/4"	6 - #10	1372	870	1814	1077	1814	1077	2625	1077	3074	1077	3074	1077
LA-338-14	68 (14 GA)	3" x 3" x 7-3/4"	6 - #10	1372	870	1814	1290	1814	1818	2625	2054	3074	2193	3074	2193
LA-338-12	97 (12 GA)	3" x 3" x 7-3/4"	6 - #10	1372	870	1814	1290	1814	1818	2625	2580	3074	2580	3074	2580

Notes:

1. Allowable loads have not been increased for wind or seismic.
2. Allowable strength shown is the lowest value from the four failure modes: screw tilting/bearing, screw shear, screw pull-over and the serviceability limit state of 1/8" deflection of CFS members.
3. It is the responsibility of design professional to design the connection of UA connectors to the supporting structure. In the test program, this connection was made with cap screws with a head diameter of 0.29". The allowable loads should be conservative for any fastener with a header diameter equal to or greater than 0.29".

UTILITY CLIP (UA & LA)

1-1/2" x 1-1/2" Angle

Length	No. of Holes
3-1/4"	6
5-1/4"	6
7-3/4"	10
9"	10
9-3/4"	10
11-3/4"	14
13-3/4"	18
15-3/4"	18

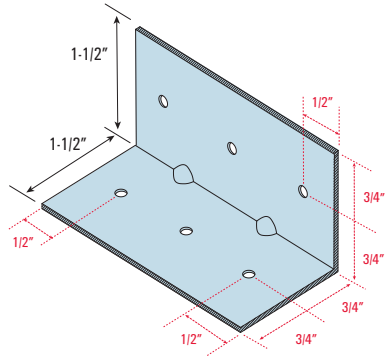

1-1/2" x 4" Angle

Length	No. of Holes
3-1/4"	12
5-1/4"	12
7-3/4"	20
9"	20
9-3/4"	20
11-3/4"	28
13-3/4"	36
15-3/4"	36

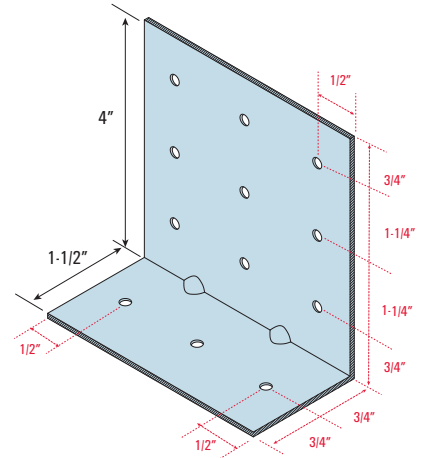

2" x 2" Angle

Length	No. of Holes
3-1/4"	6
5-1/4"	6
7-3/4"	10
9"	10
9-3/4"	10
11-3/4"	14
13-3/4"	18
15-3/4"	18

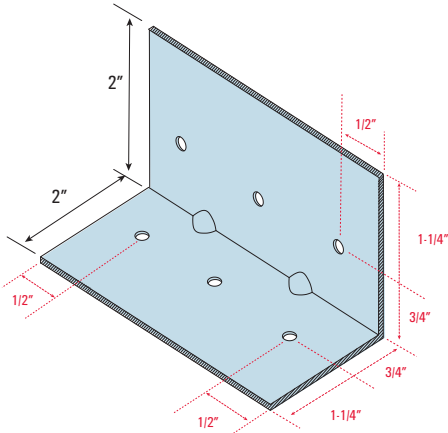

1-1/2" x 3" Angle

Length	No. of Holes
3-1/4"	9
5-1/4"	9
7-3/4"	15
9"	15
9-3/4"	15
11-3/4"	21
13-3/4"	27
15-3/4"	27

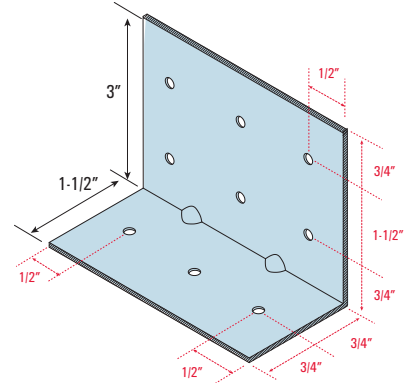

3" x 3" Angle

Length	No. of Holes
3-1/4"	12
5-1/4"	12
7-3/4"	12

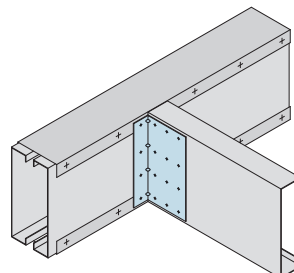
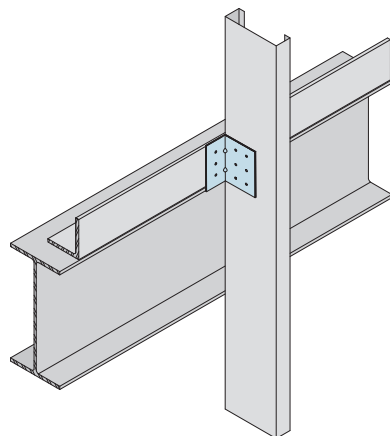
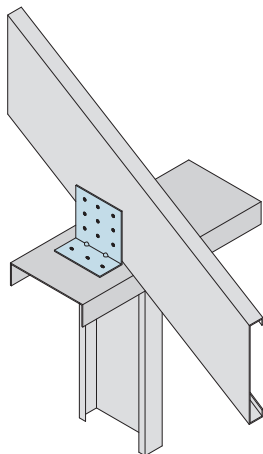
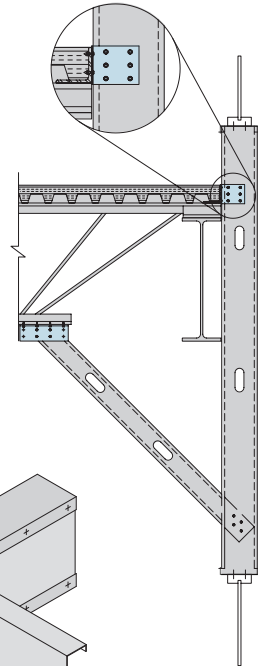
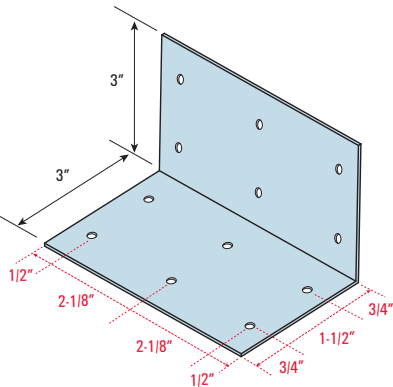

RIGID CLIP CONNECTOR (RCC)

Rigid Clip Connectors (RCC) are used to rigidly attach the bottom of a parapet stud to the structure, or where high tension or rotational restraint is required.

MATERIAL: 12ga (97 mil), 50 ksi

FINISH: Galvanized G90

INSTALLATION:

- Attach long leg of Rigid Clip Connector to web of stud with #10–16 screws through pre-punched holes.
- Attach short leg of Rigid Clip Connector to structure with a 1/2" anchor bolt per Project Engineer's design.

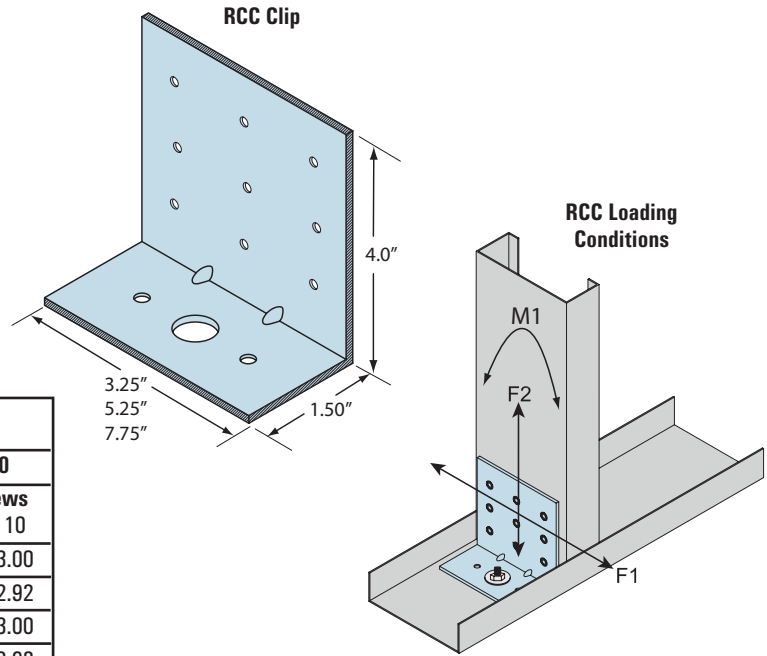

Allowable Strength of RCC in Moment (M1)

CFS Member		Allowable Strength (in-kips) Flexibility (Rad/in-lb x10 ⁶)					
Thickness (mils/ga)	Fy (ksi)	RCC358		RCC600		RCC800	
		No. of Screws		No. of Screws		No. of Screws	
33 (20)	33	3	6	3	6	5	10
		0.82	1.51	1.79	2.29	2.78	3.00
43 (18)	33	3	6	3	6	5	10
		29.3	17.4	7.28	5.9	8.21	2.92
54 (16)	50	3	6	3	6	5	10
		0.82	1.51	1.79	2.29	2.78	3.00
68 (14)	50	3	6	3	6	5	10
		29.3	17.4	7.28	5.9	8.21	2.92
97 (12)	50	3	6	3	6	5	10
		1.43	2.32	3.22	3.22	3.46	5.71
		3	6	3	6	5	10
		29.3	17.4	7.28	5.9	8.21	2.92

Rigid Clip Connector (RCC)

Model No.	Stud Size	Dimensions (in.)	Box Quantity
RCC358	3-5/8"	1-1/2 x 4 x 3-1/4	50
RCC600	6"	1-1/2 x 4 x 5-1/4	50
RCC800	8"	1-1/2 x 4 x 7-3/4	25

Allowable Strength of RCC in Tension/Compression (F2)

CFS Member		Allowable Strength (lbs)					
Thickness (mils/ga)	Fy (ksi)	RCC358		RCC600		RCC800	
		No. of Screws		No. of Screws		No. of Screws	
33 (20)	33	3	6	3	6	5	10
		530	1,060	530	1,060	884	1,767
43 (18)	33	3	6	3	6	5	10
		789	1,578	789	1,578	1,315	2,116
54 (16)	50	3	6	3	6	5	10
		1,602	2,116	1,602	2,116	2,116	2,116
68 (14)	50	3	6	3	6	5	10
		1,640	2,116	1,640	2,116	2,116	2,116
97 (12)	50	3	6	3	6	5	10
		1,640	2,116	1,640	2,116	2,116	2,116

Allowable Strength of RCC in Shear (F1)

CFS Member		Allowable Strength (lbs)					
Thickness (mils/ga)	Fy (ksi)	RCC358		RCC600		RCC800	
		No. of Screws		No. of Screws		No. of Screws	
33 (20)	33	3	6	3	6	5	10
		450	450	600	710	850	850
43 (18)	33	3	6	3	6	5	10
		450	450	600	710	850	850
54 (16)	50	3	6	3	6	5	10
		840	1,000	1,250	1,500	1,860	1,990
68 (14)	50	3	6	3	6	5	10
		840	1,000	1,250	1,500	1,860	1,990
97 (12)	50	3	6	3	6	5	10
		840	1,000	1,250	1,500	1,860	1,990

Notes:

1. Tabulated values are based on #10-16 screws with ultimate shear capacity of 1,600 lbs per screw.
2. Allowable loads have not been increased for wind or seismic.
3. Tabulated loads are based on 1/2" diameter bolt with 1/2" Type A plain washer with a nominal outside diameter of 1.062" & nominal thickness of 0.095".
4. It is the responsibility of the design professional to design the connection of the RCC to the supporting structure.
5. Use linear interaction for combination of F1, F2, and M1.
6. The 1/4" thick Heavy Duty Washer (HDW) meets ASTM A36 Standard Specification for Carbon Structural Steel and is made from hot rolled flat bar and painted gray for corrosion resistance.

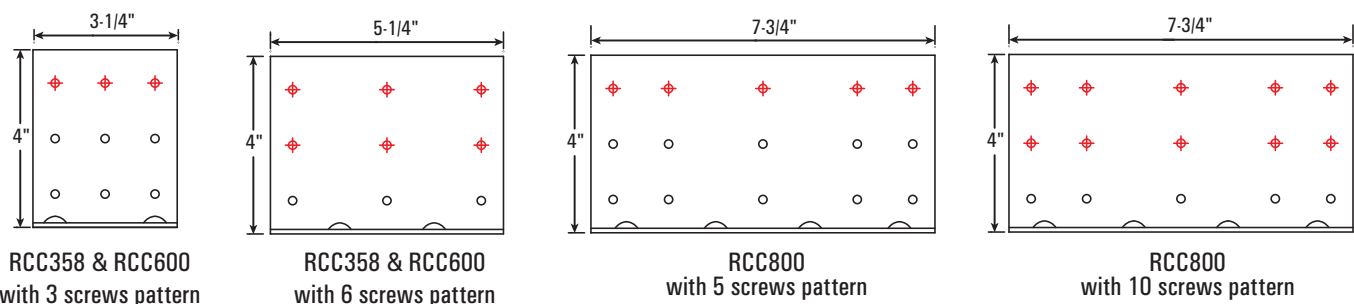

RIGID CLIP CONNECTOR WITH HDW WASHER

NEW

Rigid Clip Connectors (RCC) are used to rigidly attach the bottom of a parapet stud to the structure, or where high tension or rotational restraint is required.

MATERIAL: 1/4" Carbon Structural Steel Hot Rolled Heavy Duty Washer (HDW), 36 ksi

FINISH: HDW washer is painted gray for corrosion resistance.

INSTALLATION:

- Attach long leg of Rigid Clip Connector to web of stud with #10-16 screws through pre-punched holes.
- Attach short leg of Rigid Clip Connector to structure with a 1/2" anchor bolt per Project Engineer's design.

Allowable Strength of RCC with HDW (Washer) in Moment (M1)

CFS Member		Allowable Strength (in-kips) Flexibility (Rad/in-lb x10 ⁶)					
Thickness (mil/ga)	Fy (ksi)	RCC358		RCC600		RCC800	
		No. of Screws 3	No. of Screws 6	No. of Screws 3	No. of Screws 6	No. of Screws 5	No. of Screws 10
33 (20)	33	0.99	1.94	2.15	2.35	3.37	3.82
		28.4	8.07	4.06	4.06	6.39	1.7
43 (18)	33	0.99	1.94	2.15	2.35	3.37	3.82
		28.4	8.07	4.06	4.06	6.39	1.7
54 (16)	50	2.10	3.99	4.38	4.69	8.06	8.03
		28.4	8.07	4.06	4.06	6.39	1.7
68 (14)	50	2.10	3.99	4.38	4.69	8.06	8.03
		28.4	8.07	4.06	4.06	6.39	1.7
97 (12)	50	2.10	3.99	4.38	4.69	8.06	8.03
		28.4	8.07	4.06	4.06	6.39	1.7

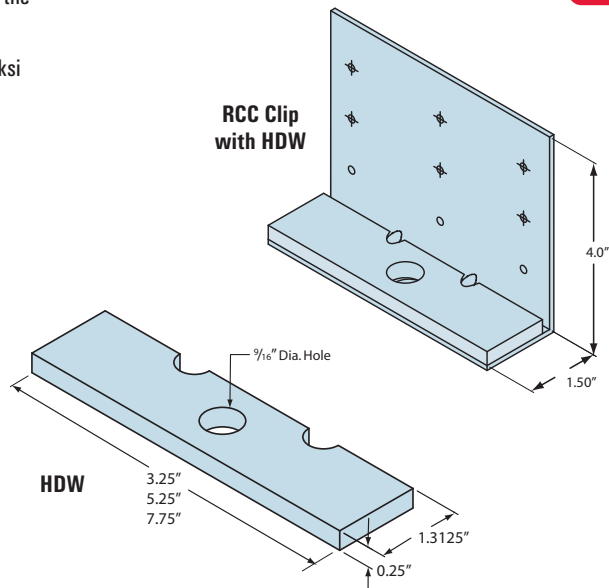

Heavy Duty Washer (HDW)

Model No.	Stud Size	Dimensions (in.)	Box Quantity
HDW358	3-5/8"	1/4 x 1-5/16 x 3-1/4	50
HDW600	6"	1/4 x 1-5/16 x 5-1/4	50
HDW800	8"	1/4 x 1-5/16 x 7-3/4	25

Allowable Strength with HDW (Washer) in Shear (F1)

CFS Member		Allowable Strength (lbs)					
Thickness (mils/Ga)	Fy (ksi)	RCC358		RCC600		RCC800	
		No. of Screws 3	No. of Screws 6	No. of Screws 3	No. of Screws 6	No. of Screws 5	No. of Screws 10
33 (20)	33	480	480	660	760	980	980
43 (18)	33	480	480	660	760	980	980
54 (16)	50	1,070	1,100	1,450	1,670	2,160	2,160
68 (14)	50	1,070	1,100	1,450	1,670	2,160	2,160
97 (12)	50	1,070	1,100	1,450	1,670	2,160	2,160

Allowable Strength with HDW (Washer) in Tension/Compression (F2)

CFS Member		Allowable Strength (lbs)					
Thickness (mils/Ga)	Fy (ksi)	RCC358		RCC600		RCC800	
		No. of Screws 3	No. of Screws 6	No. of Screws 3	No. of Screws 6	No. of Screws 5	No. of Screws 10
33 (20)	33	530	1,060	530	1,060	884	1,767
43 (18)	33	789	1,578	789	1,578	1,315	2,630
54 (16)	50	1,602	3,205	1,602	2,219	2,671	3,244
68 (14)	50	1,640	3,244	1,640	3,205	2,733	3,244
97 (12)	50	1,640	3,244	1,640	3,244	2,733	3,244

Notes:

1. Tabulated values are based on #10-16 screws with ultimate shear capacity of 1,600 lbs per screw.
2. Allowable loads have not been increased for wind or seismic.
3. Tabulated loads are based on 1/2" diameter bolt with 1/2" Type A plain washer with a nominal outside diameter of 1.062" & nominal thickness of 0.095".
4. It is the responsibility of the design professional to design the connection of the RCC to the supporting structure.
5. Use linear interaction for combination of F1, F2, and M1.
6. The 1/4" thick Heavy Duty Washer (HDW) meets ASTM A36 Standard Specification for Carbon Structural Steel and is made from hot rolled flat bar and painted gray for corrosion resistance.

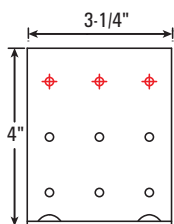

RCC358 & RCC600 with 3 screws pattern

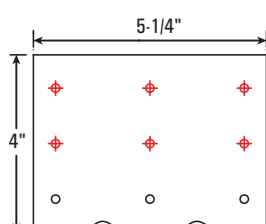

RCC358 & RCC600 with 6 screws pattern

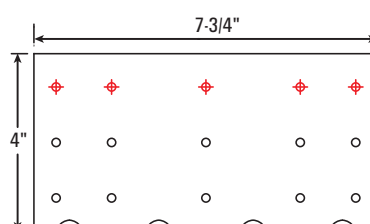

RCC800 with 5 screws pattern

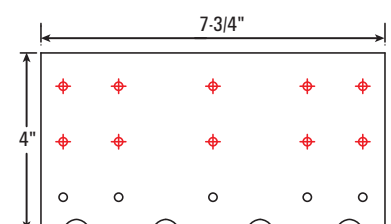

RCC800 with 10 screws pattern

RIGID CONNECTORS

HOLDOWN (S/HD & S/HDS)



The S/HD series of holdowns is designed for installation with either screws or bolts into the studs or column. The S/HDS series installs with #14 screws and has been designed to utilize fewer fasteners to reduce installation time. The S/HDB series is ideal for bolt-on applications where the cold-formed stud manufacturer can re-punch the bolt holes.

MATERIAL: S/HD8 and S/HD10 – 118 mil (10 ga) with 3/8" plate, S/HD15 – 171 mil (7 ga) with 1/2" plate.

FINISH: Simpson gray paint. Hot-dip galvanized is available.

INSTALLATION:

- Use all specified fasteners.
- The design engineer may specify any alternate anchorage calculated to resist the tension load for your specific job.
- Anchor bolt washer is not required.

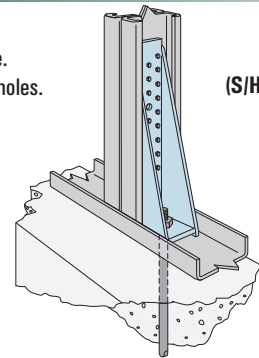

S/HD10
(S/HD10S similar)

Model No.	Dimensions (in.)			Fasteners		Allowable Tension Loads (133) Back-to-Back Stud			Holdown Deflection at Highest Allowable Design Load
	W	H	CL	Anchor Dia.	Screws	2–33 mil. (2–20 ga.)	2–43 mil (2–18 ga.)	2–54 mil (2–16 ga.)	
S/HD8	2-1/2	13-7/8	1-1/2	7/8	24-#10	7615	8460	8940	0.085
S/HD10	2-1/2	16-1/8	1-1/2	7/8	30-#10	9520	9665	9665	0.093
S/HD15	2-3/4	21-1/2	1-1/2	1	48-#10	–	12200	14405	0.070
S/HD8S	2-5/16	11	1-1/2	7/8	17-#14	8580	11070	11070	0.0695
S/HD10S	2-5/16	13-1/2	1-1/2	7/8	22-#14	8580	11120	12200	0.0960
S/HD15S	2-7/16	17	1-3/8	1	30-#14	8580	11120	13500	0.0970

S/HD15

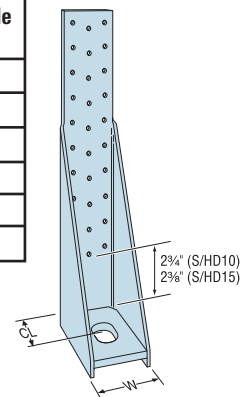

Notes:

1. For load at (100), multiply table value by 0.75 where the 1/3 increase is not permitted.
2. Values are test limited. For load at (100), no reduction necessary. For load at (133) for 1/3 increase, no further increase allowed.
3. The Designer shall specify the anchor embedment and configuration.
4. Deflection at Highest allowable Design Load: The deflection of a holddown measured between the anchor bolt and the strap portion of the holddown when loaded to the highest allowable load listed in the catalog table. This movement is strictly due to the holddown deformation under a static load test conducted on a steel jig.

TENSION TIE (S/LTT & S/HTT)



The S/HTT14 is a single-piece formed tension tie—no rivets, and a 4-ply formed seat which won't unfold during loading. No washers are required. The S/LTT and S/HTT Tension Ties are ideal for retrofit or new construction projects. They provide high strength, post-pour, concrete-to-steel connections.

MATERIAL: See table.

FINISH: Galvanized – G90

INSTALLATION:

- Use all specified fasteners.
- Use the specified number and type of screws to attach the strap portion to the steel stud. Bolt the base to the wall or foundation with a suitable anchor; see table for the required bolt diameter.

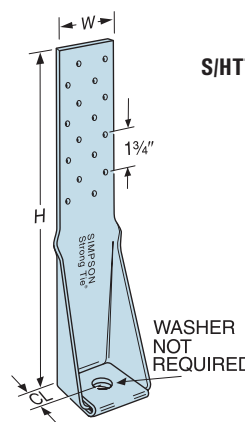

S/HTT14

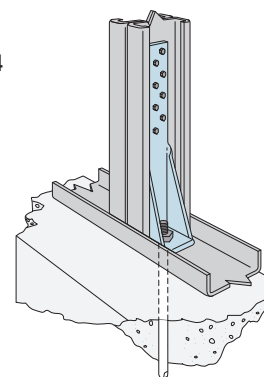

WASHER NOT REQUIRED

Model No.	Material (mil/ga)		Dimensions (in.)			Fasteners		Allowable Tension Loads (133)	Holdown Deflection at Highest Allowable Design Load
	Strap	Plate	W	H	CL	Anchor Bolts	Screws		
S/LTT20	97 (12 ga)	229 (3 ga)	2	20	1-1/2	1/2	8-#10	1600	0.209
S/HTT14	111 (11 ga)	–	2-1/2	15	1-1/4	5/8	14-#10	4325	0.041

S/LTT20

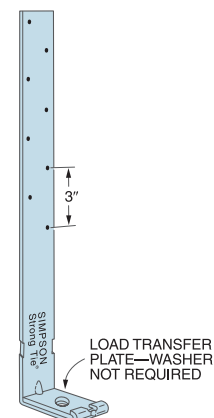

LOAD TRANSFER PLATE—WASHER NOT REQUIRED

Notes:

1. The Designer shall specify the anchor embedment and configuration.
2. Load at (100), no reduction necessary. Load at (133) for 1/3 increase, no further increase allowed.
3. Loads are based on attachment of CFS members having a minimum thickness of 33 mil (20 ga).
4. Deflection at Highest allowable Design Load: The deflection of a holddown measured between the anchor bolt and the strap portion of the holddown when loaded to the highest allowable load listed in the catalog table. This movement is strictly due to the holddown deformation under a static load test conducted on a steel jig.

WRC RIGID CLIP

NEW

The WRC series of clips connects exterior studs to the building structure and resists horizontal and lateral loads. The WRC has embossments and a continuous flange to allow for excellent load values. 25 pieces per box.

Part No.	Ga. (Mil)	Material	Finish	Size
WRC362	14ga (68)	50 KSI	G-90	4" x 1.5" x 3.5"
WRC600	14ga (68)	50 KSI	G-90	4" x 1.5" x 5.5"
WRC800	14ga (68)	50 KSI	G-90	4" x 1.5" x 7.5"
WRC1000	14ga (68)	50 KSI	G-90	4" x 1.5" x 9.5"
WRC1200	14ga (68)	50 KSI	G-90	4" x 1.5" x 11.5"

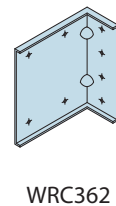
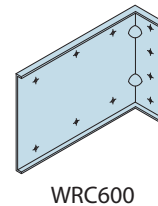
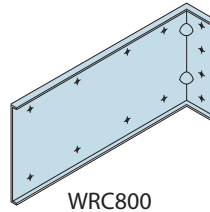
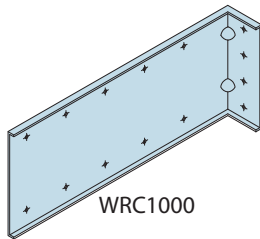
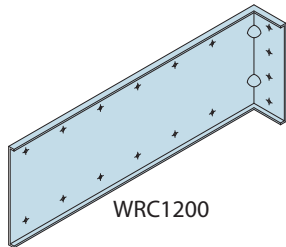
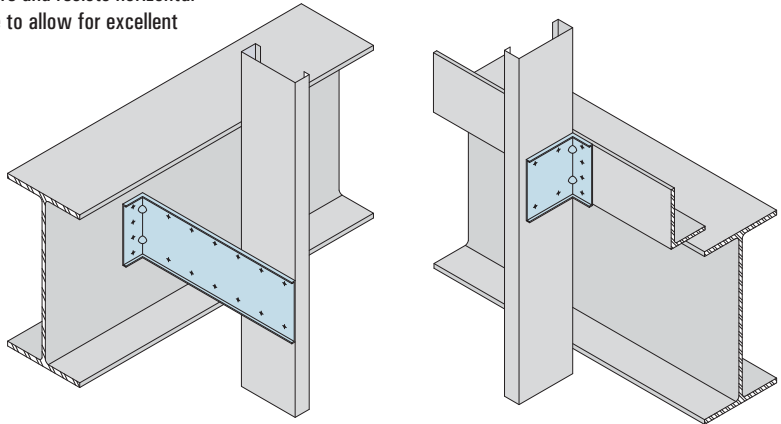

SEISMIC & HURRICANE TIE (S/H1A)

SIMPSON Strong-Tie

S/H1A was designed to fit within several proprietary truss chords to provide uplift resistance.

MATERIAL: 18 ga (43 mil) 33ksi

FINISH: Galvanized – G90

INSTALLATION:

- Use all specified fasteners.
- S/H1A can be installed with flanges facing outward (reverse of the illustration) when installed inside a wall for truss applications.
- S/H1A does not replace solid blocking.

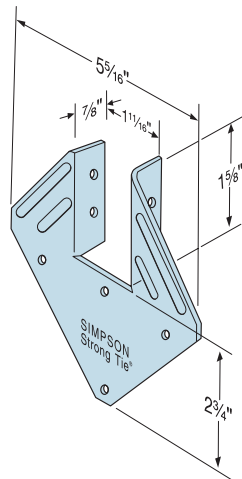

S/H1A

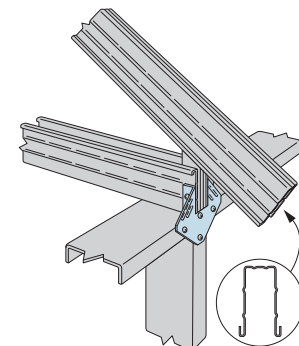
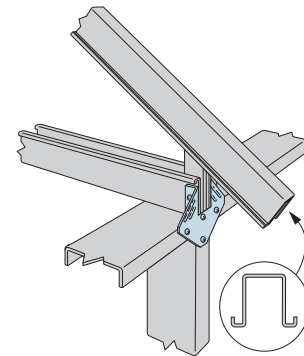

Model No.	Fasteners			Truss Thickness mil (ga)	Allowable Loads (100)		
	Truss	Top Track	Studs		Plate/Wall Stud Thickness mil (ga)		
					33 mil (20 ga)	43 mil (18 ga)	54 mil (16 ga)
S/H1A	4-#10	3-#10	1-#10	27 (22 ga)	470	470	470
	4-#10	3-#10	1-#10	33 (20 ga)	510	550	690
	4-#10	3-#10	1-#10	43 (18 ga)	510	550	690
	4-#10	3-#10	1-#10	54 (16 ga)	590	675	850

Notes:

1. Load at (100), no reduction is necessary. Load at (133) for 1/3 increase, no further increase allowed.
2. Loads are based on truss steel properties of $F_y=50$ ksi and $F_u=65$ ksi. Reduce load direct proportionally for lower steel strength. For example: Truss with 43 mil (18 ga) thickness has a steel properties of $F_y=33$ ksi, $F_u=45$ ksi and is connected to 43 mil plate and wall stud. The adjusted allowable load = $550 \text{ lbs} \times \text{minimum } [33/50 \text{ or } 45/65] = 363 \text{ lbs}$.

SEISMIC & HURRICANE TIE (S/H)



Designed to provide seismic and wind ties for trusses or joists, this versatile line may be used for general tie purposes, strongback attachments, and as all-purpose ties where one member crosses another.

MATERIAL: 18 ga (43 mil) 33ksi

FINISH: Galvanized – G90

INSTALLATION:

- Use all specified fasteners.
- The S/H1 can be installed with flanges facing outward (reverse of illustration) when installed inside a wall for truss applications.
- Hurricane Ties do not replace solid blocking
- S/H2.5 ties are only shipped in equal quantities of rights and lefts.

Model No.	Fasteners			Truss Thickness (mil/ga)	Allowable Tension Loads (100 & 133)		
	Rafter	Plate	Stud		Uplift	Lateral	
						F1	F2
S/H1	3-#10	2-#10	1-#10	43 (18 ga)	265	100	115
S/H2	3-#10	-	3-#10	43 (18 ga)	315	-	-
S/H2.5	4-#10	-	4-#10	43 (18 ga)	415	90	125

Notes:

1. Load at (100), no reduction is necessary. Load at (133) for 1/3 increase, no further increase allowed.
2. Loads are based on attachment of cold-formed steel members having a minimum thickness of 33 mil (20 ga).
3. Hurricane Ties are shown installed on the outside of wall for clarity. Installation inside of wall is acceptable. For Continuous Load Path, connections must be on same side of wall.

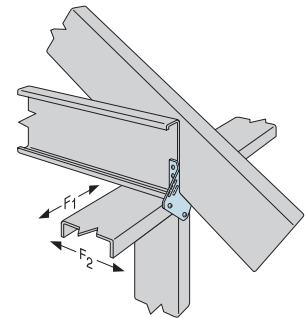
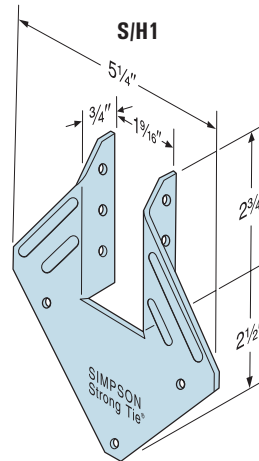

Typical S/H1 installation

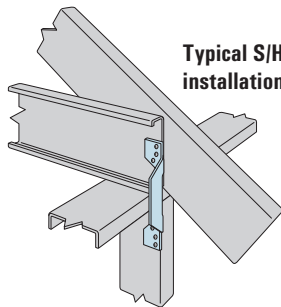

Typical S/H2 installation

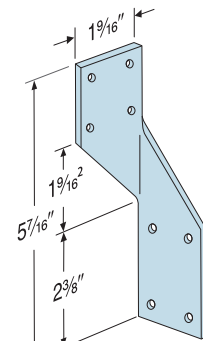
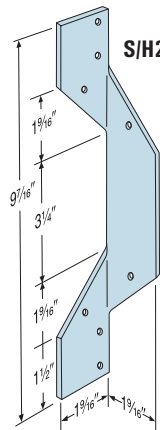

S/H2.5

TWIST STRAP (MTS)



Twist straps provide a tension connection between two members. They resist uplift at the heel of a truss economically. The 3" bend section eliminates interference at the transition points between steel members.

MATERIAL: 16 ga (54 mil) 50ksi

FINISH: Galvanized – G90

INSTALLATION:

- Use all specified fasteners.

Model No.	Material Thickness (mil/ga)	Length	Fasteners (Total)			Allowable Tension Loads			
			Rafter/Stud/Joist Thickness			33 mil (20ga)		43 mil (18ga)	
			33 mil (20ga)	43 mil (18ga)	54 mil (16ga)	(100)	(133)	(100)	(133)
MTS12	54 (16ga)	12"	12 -#10	8 -#10	5 -#10	995	995	995	995

Notes:

1. All straps have additional fastener holes.
2. Install half of the fasteners on each end of strap to achieve full loads.
3. Load at (100), no reduction necessary. Load at (133) for 1/3 increase, no further increase allowed.
4. All straps have the twist in the center of the strap.
5. Twist straps do not have to be wrapped over the truss to achieve the load.
6. May be installed on the inside face of the stud.
7. Loads are based on steel with 43 mil (18 ga) minimum.
8. Not all fastener holes need to be filled as additional fastener holes provided. Install fasteners symmetrically.

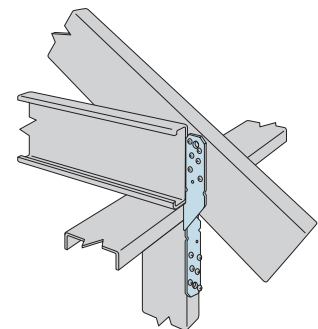
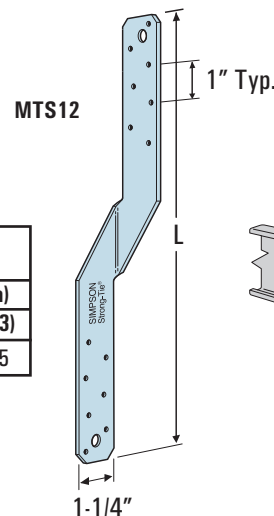

Typical installation truss to steel studs

GUSSET PLATE (UNPUNCHED) (GP)

Designed for a variety of construction connections. Used for conditions such as roof, wall and floor framing connections. GPU Plate is used for in plane truss chord connections, header to jamb connections and tension strap connections. Adapts to varying construction tolerances.

MATERIAL: See Table, 50ksi

FINISH: Galvanized coating weight as requested.

INSTALLATION:

- As specified by design.
- 16 Gauge (54 mils) .0566" Design Thickness
- 12 Gauge (97 mils) .1017" Design Thickness
- Custom sizes available upon request.



Gusset Plate (Unpunched)

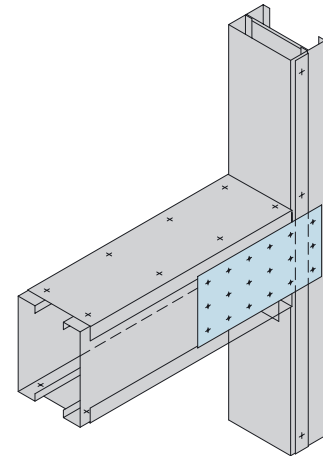

Model No.	Gauge	Size
GPU66-16	16	6"x6"
GPU612-16	16	6"x12"
GPU1212-16	16	12"x12"
GPU66-12	12	6"x6"
GPU612-12	12	6"x12"
GPU1212-12	12	12"x12"

STRAP TIE (ST/LSTA/MST/MSTA)



Straps are load rated and provide the correct thickness and number of fasteners the specifier is looking for compared with the field fabricated straps.

Install Strap Ties where top or bottom plates are cut, at wall intersections, and as ridge ties. LSTA and MSTA straps are engineered for use on members with a minimum width of 1-1/2". Reduce the allowable load based on the size and quantity of fasteners used.

Refer to applicable code for minimum edge and end distances.

FINISH: Galvanized – G90

INSTALLATION:

- Use all specified fasteners.

S/MST

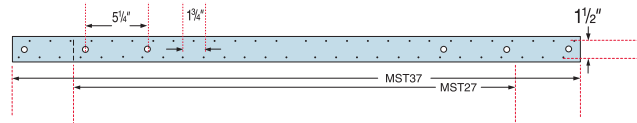

ST

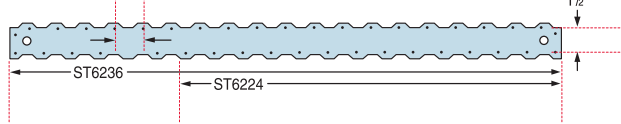

LSTA and MSTA

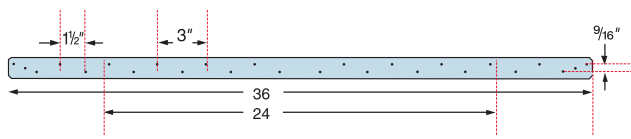

Model No.	Material Thickness mil (ga)	Dimensions		Fasteners (Total)			Allowable Tension Loads					
				Rafter/Stud/Joist Thickness			33 mil (20 ga)		43 mil (18 ga)		54 mil (16 ga)	
		W	L	33 mil (20 ga)	43 mil (18 ga)	54 mil (16 ga)	(100)	(133)	(100)	(133)	(100)	(133)
LSTA24	33 (20 ga)	1-1/4	24	14-#10	12-#10	10-#10	1190	1590	1190	1590	1190	1590
LSTA36	43 (18 ga)	1-1/4	36	18-#10	16-#10	14-#10	1555	2070	1555	2070	1555	2070
MSTA24	43 (18 ga)	1-1/4	24	18-#10	12-#10	10-#10	1555	2070	1555	2070	1555	2070
MSTA36	54 (16 ga)	1-1/4	36	24-#10	18-#10	16-#10	1950	2600	1950	2600	1950	2600
ST6224	54 (16 ga)	2-1/16	23-5/16	28-#10	20-#10	12-#10	2455	3275	2455	3275	2455	3275
ST6236	68 (14 ga)	2-1/16	33-13/16	40-#10	30-#10	18-#10	3535	4715	3760	5015	3760	5015
MST27	97 (12 ga)	2-1/16	27	30-#10	30-#10	22-#10	2650	3535	3945	5260	5025	6700
MST37	97 (12 ga)	2-1/16	37-1/2	42-#10	40-#10	22-#10	3710	4950	5025	6700	5025	6700

Notes:

1. Use half of the fasteners in each member being connected to achieve the listed loads.
2. Loads are based on lesser of steel capacity and fastener calculation.
3. Tabulated loads shown at (100) do not include steel stress increase.
Tabulated loads shown at (133) include a 1/3 stress increase on the steel.

SOLID BLOCKING (JB)

Joist Blocking is pre-cut to fit securely between joists to prevent joist rotation. Joist Blocking is a one piece system in lieu of the typical 3 piece detail offering an economical alternative to installing conventional clips and solid web members.

MATERIAL: 16 ga (54 mil) 50ksi

FINISH: Galvanized – G90

INSTALLATION:

- Position the pre-cut Joist Blocking to fit securely between the joists.
- (4) #10 - 16 screws are required to secure the blocking to the joist flanges using the pre-punched holes.
- Solid blocking should be installed 7' o.c. maximum along the joist length.
- Fits up to 2" flange joist product.
- Blocking for 2-1/2" and 3" flanges available as a special order.

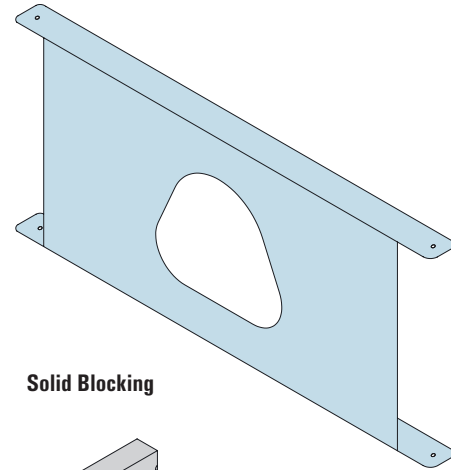

Solid Blocking

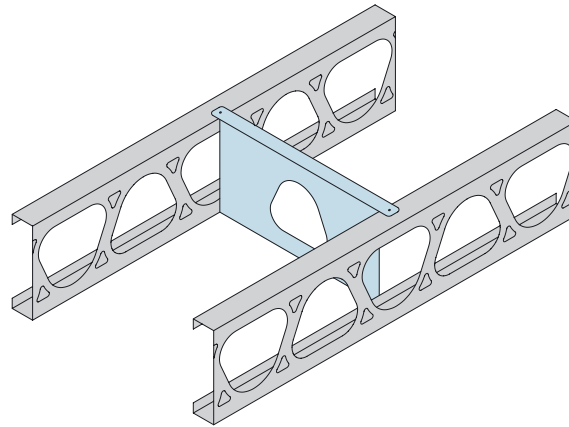

Model No.	Size	Spacing (o.c.)	Box Quantity
800JB-12	8"	12	10
925JB-12	9-1/4"	12	10
1000JB-12	10"	12	10
1125JB-12	11-1/4"	12	10
1200JB-12	12"	12	10
1400JB-12	14"	12	10
800JB-16	8"	16	10
925JB-16	9-1/4"	16	10
1000JB-16	10"	16	10
1125JB-16	11-1/4"	16	10
1200JB-16	12"	16	10
1400JB-16	14"	16	10
800JB-24	8"	24	10
925JB-24	9-1/4"	24	10
1000JB-24	10"	24	10
1125JB-24	11-1/4"	24	10
1200JB-24	12"	24	10
1400JB-24	14"	24	10

WEB STIFFENER (JS)

Web Stiffeners are used to provide reinforcement of joist webs to prevent crippling. Web reinforcement is often required by design to enhance the load capacity of joists. Web stiffeners are installed on the inside or outside of the joist.

MATERIAL: 16 ga (54 mil) 50ksi

FINISH: Galvanized – G90

INSTALLATION:

- Web stiffeners are centered within the load or reaction bearing width.
- Web stiffeners require full bearing along their supported ends.
- (4-6) #10 - 16 screws are required to attach the stiffener to the joist web using pre-punched holes.

Web Stiffener

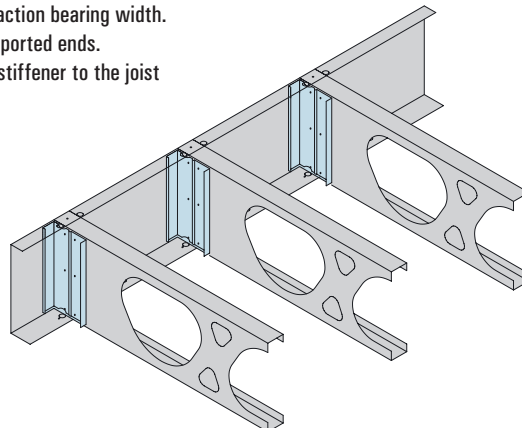
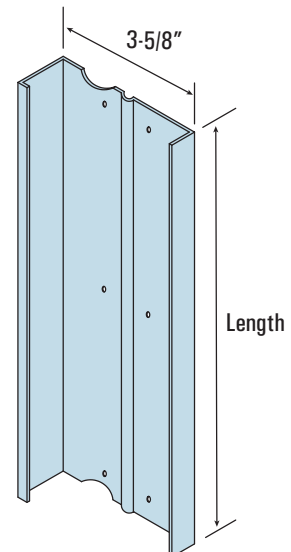

Model No.	Size	Box Quantity
8JS-362	8"	24
925JS-362	9 1/4"	24
10JS-362	10"	24
1125JS-362	11 1/4"	24
12JS-362	12"	24
14JS-362	14"	24



REINFORCING & SKEWABLE ANGLE (LS)

LS angles are load rated and provide the correct thickness and number of fasteners the specifier is looking for compared with field fabricated clip angles. General utility reinforcing angles with multiple uses. LS—Field-adjustable angles attach members at intersecting angles.

MATERIAL: LS – 18 ga (43 mil) 33ksi

FINISH: Galvanized – G90

INSTALLATION:

- Use all specified fasteners.
- LS—field-skewable; bend one time only.
- Joist must be constrained against rotation when using a single S/LS per connection.

Model No.	Length	Screws	Allowable Loads (100)				
			33 mil (20ga)		43 mil (18ga)		54 mil (16ga)
			F1	F2	F1	F1	F1
LS50	4-7/8"	4 – #10	200	–	420	500	–
LS70	6-3/8"	6 – #10	465	–	630	715	–
LS90	9"	10 – #10	795	–	1050	1740	–

Notes:
 1. Tabulated loads are governed by tests and may not be increased.
 2. Loads are for one part only.

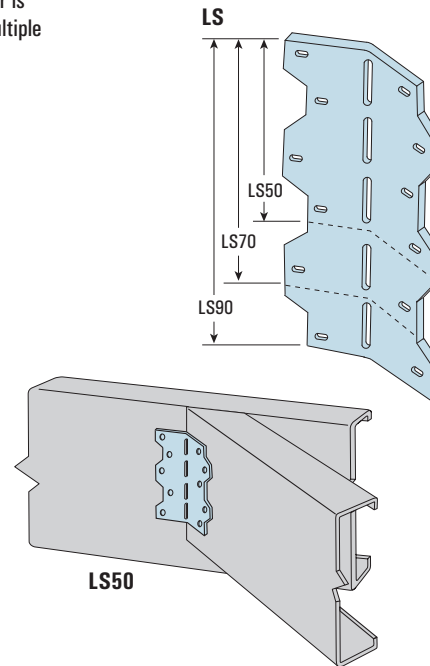

COILED STRAP (CS)

CS are continuous utility straps which can be cut to length on the job site. Packaged in lightweight (about 40 pounds) cartons.

MATERIAL: 33 mil (20 ga), 43 mil (18 ga) & 54 mil (16 ga)

FINISH: Galvanized – G90

INSTALLATION:

- Use all specified fasteners.
- Refer to the applicable code for minimum edge and end distances.
- The table shows the maximum allowable loads and the screws required to obtain them. See footnote #1. Fewer screws may be used; reduce the allowable load by the code lateral load for each fastener subtracted from each end.

Coiled Strap

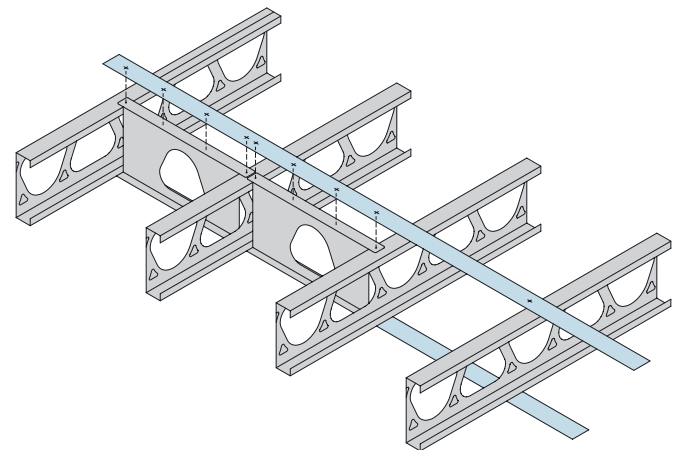
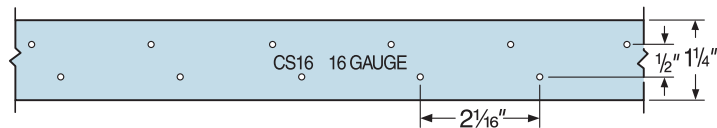

Typical CS installation as a floor-to-floor tie

Model No.	Length	Material Thickness (mil/ga)	Width	Fasteners (Total)			Allowable Tension Loads	
				Rafter/Stud/Joist Thickness			33 mil (20ga), 43 mil (18ga) & 54 mil (16ga)	
				33 mil (20ga)	43 mil (18ga)	54 mil (16ga)	(100)	(133)
CS16	150'	54 (16ga)	1-1/4"	18 – #10	12 – #10	8 – #10	1550	2065
CS18	200'	43 (18ga)	1-1/4"	14 – #10	10 – #10	6 – #10	1235	1645
CS20	250'	33 (20ga)	1-1/4"	12 – #10	8 – #10	6 – #10	945	1260

Notes:
 1. Use half of the fasteners in each member being connected to achieve the listed loads.
 2. For CS straps: End Length (inches) = 1/2 total fasteners + 1".
 3. Total Cut Length = End Length + Clear Span + End Length.
 4. For a reduced number of screws, allowable load = (#screws used/#screws in table) x table load.
 5. Loads are based on lesser of steel strap capacity and 2001 AISI NASPEC fastener calculation.
 6. Tabulated loads shown at (100) do not include steel stress increase.
 Tabulated loads shown at (133) include a 1/3 stress increase on the steel.

JOIST FRAMING CONNECTORS

S/LBV HANGER



Precision forming with manufacturing quality control provides dimensional accuracy and helps ensure proper bearing area and connection. S/LBV flanges encapsulate the top flange of the joist.

MATERIAL: S/LBV – 14 ga (68 mil) 50ksi

FINISH: Galvanized – G90

INSTALLATION:

- S/LBV may be used for weld-on applications; a minimum of 1/8" x 2" fillet weld on each top flange is required. Distribute the weld equally on both top flanges. Consult the code for special considerations when welding galvanized steel. Uplift loads do not apply.

OPTIONS:

- Skew only: S/LBV series can be factory skewed to a maximum of 45 degrees.

Model No.	Dimensions			Screws			Allowable Down Loads (100)	
	W	H	B	Top	Face	Joist	68 mil (14ga)	Welded
S/LBV	1-9/16" to 5-1/2"	6" to 20"	2-1/4"	4 -#10	2-#10	3-#10	2870	—
				4 -#10	2-#10	3-#10	2025	—
				Weld	—	3-#10	—	2865

Notes:
 1. Tabulated loads are governed by tests and may not be increased.
 2. Designer shall insure that the joist member adequately transfers load to the hanger.
 Steel header must be braced to prevent buckling per Designer specification.

S/LBV Hanger

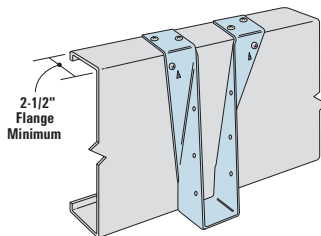
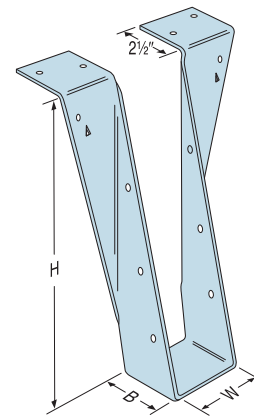

S/LBV installation with a CFS steel header

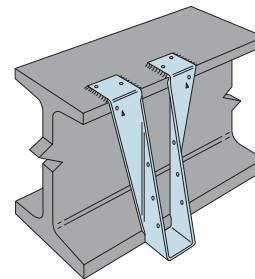

S/LBV are acceptable for weld-on applications

S/BA HANGER



The S/BA top-flange hanger is a cost-effective alternative to heavier, special-order hangers. The S/BA is value engineered and tested to achieve higher allowable loads and increased performance. It may be fastened with screws or powder actuated fasteners or welded to the header, providing more design options and greater versatility.

MATERIAL:

68 mil (14 ga) FINISH: Galvanized

INSTALLATION:

- Use all specified fasteners. See General Notes in the Cold-Formed Steel Connectors catalog (C-CFS).
- S/BA may be used for weld-on applications. The minimum required weld to the top flanges is 1/8" x 2" fillet weld to each side of each top flange tab. Consult the AWS Structural Welding Code for special considerations when welding galvanized steel.
- S/BA may be installed using powder-actuated fasteners. A 0.157" x 5/8," powder-actuated fastener shall be installed using the appropriate level of powder load so the entire pointed portion of the fastener penetrates through the steel. A powder-actuated fastener with a "tophat" crush sleeve is recommended in case the head of the fastener is not fully flush with the connector.
- Uplift loads do not apply.

S/BA

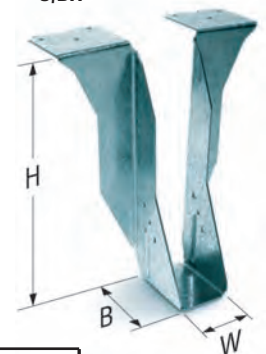

S/BA Series Model No.	W (in)	H (in)
S/BA2.12/8	2-1/8"	8
S/BA2.12/10		10
S/BA2.12/12		12
S/BA2.12/14		14
S/BA4.18/8	4-3/16"	8
S/BA4.18/10		10
S/BA4.18/12		12
S/BA4.18/14		14

Model No.	Dimensions			Fasteners		Allowable Downloads
	W	H	B	Top	Joist	
S/BA - Screw ⁷	See table	See table	3	6-#10Screws	1-#10	3290
S/BA - Weld				1/8" x 2" Weld	1-#10	2920
S/BA - P.A.T. fasteners ⁶				6-P.A.T. fasteners ^{4,5,6}	1-#10	2685

Notes:
 1. Tabulated loads are governed by tests and may not be increased. Refer to the Cold-Formed Steel Connectors catalog (C-CFS) for additional information.
 2. Designer shall ensure that the joist member adequately transfers load to the hanger.
 3. Steel header by Designer.
 4. Powder-actuated fasteners may be installed in up to 3/8" steel. Steel header shall have minimum Fy = 36,000 psi.
 5. Loads are based on using the Simpson Strong-Tie® PDPAT-62KP powder-actuated fastener and a minimum Red (level 5) powder load.
 6. Installations of powder-actuated fasteners may vary due to, but not limited to, the type of powder-actuated tool, cleanliness of tool, type of powder load and steel.
 7. Allowable loads are based on testing with a minimum of 2-1/2" flange supporting member, and CFS thickness of 68 mil (14 ga) for header and joist.

LEDGER CONNECTOR SYSTEM (ICFVL)

The ICFVL Ledger connector System is engineered to solve the challenges of mounting steel ledgers to insulated concrete form (ICF) walls. Simpson's ICF component of the system, the ICFVL, is designed to provide both vertical and lateral, in-plane performance. The System is still quick, versatile and easy to use but now provides so much more! There are many benefits over traditional anchor bolting, including better on center spacing in most cases, faster installation.

Simpson's ICFVL is made from galvanized, 14 gauge steel. The embedded legs are embossed for additional stiffness and the hole allows for concrete to flow through and around the connector. The exposed flange on the face of the ICF provides a structural surface for mounting a steel ledger.

MATERIAL: ICFVL – 14 ga (68 mil) 50ksi

FINISH: Galvanized – G90

Ledger Type	Fasteners	Allowable Loads (lbs)	
		Download (100/115/125)	Lateral F1 (133/160)
Steel	4 – #14" x 3/4"	1660	1525

Notes:

1. Loads apply to ICF foam thicknesses of 2-5/8" or less.
2. Alternately, #14 x 3/4" fastener may be used.
3. Tabulated loads may not be increased.
4. Concrete $f'c = 2500$ psi minimum.
5. When combining download and lateral loads, Designer shall evaluate as follows: Design Download/Allowable Lateral Load + Design Lateral Load/Allowable Lateral Load ≤ 1 .

Ledger Type	ICFVL Spacing to Replace Anchor Bolts (in.)							
	1/2" Dia. Anchors at:				5/8" Dia. Anchors at:			
	12" o.c.	24" o.c.	36" o.c.	48" o.c.	12" o.c.	24" o.c.	36" o.c.	48" o.c.
68 mils (0.068")	11	22	33	44	9	18	27	36
54 mils (0.054")	15	30	45	48	12	24	36	48

Notes:

1. The Designer may specify different spacing based on the load requirements.
2. For steel ledgers, the 68 mil ledger spacing is closer than the 54 mil ledger because the calculated load of a bolt is higher in a thicker piece of steel.
3. Steel ledger values are based on steel. $F_u = 60$ ksi.

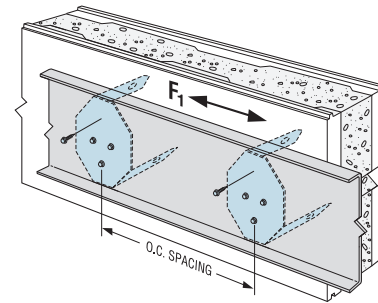
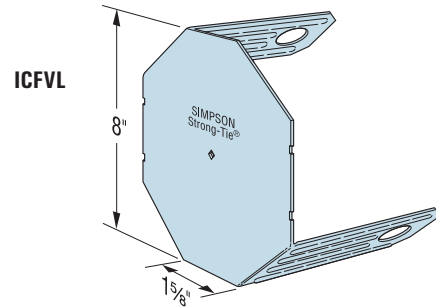

FRAMING PLATE (LTP5)

The LTP5 spans subfloor at the top of the blocking or rim joist. The embossments enhance performance and allows for design flexibility.

MATERIAL: LTP5 – 20 ga (33 mil) 33ksi

FINISH: Galvanized – G90

INSTALLATION:

- Use all specified fasteners.

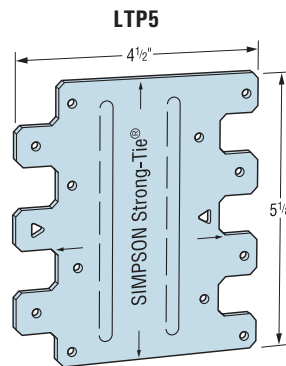

LTP5 Installation

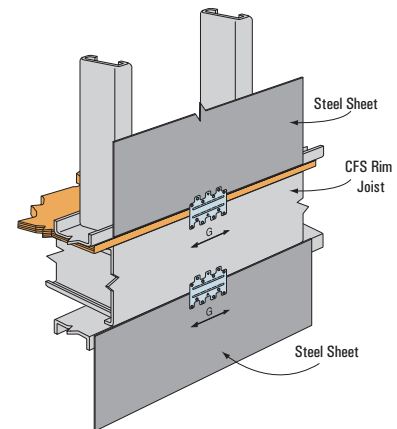

Model No.	Type of Connection	Direction of Load	Fasteners		Allowable Loads 43 mil (18ga)	
			To Rim Joist	To Plates & Shearwall	(100)	(133)
			1		7 – #10	7 – #10
LTP5	2	G	7 – #10	7 – #10	1110	1110
	3		7-8D X 1-1/2	7 – #10	625	730

Notes:

1. Tabulated loads shown at (100) do not include steel stress increase. Tabulated loads shown at (133) include a 1/3 increase on the steel.
2. Allowable loads are for one anchor.
3. When anchors are installed on each side of joist, the minimum joist thickness is 3".
4. Allowable loads are based on steel (stud & sheet) of 43 mil (18ga) minimum.

STEEL JOIST HANGER (S/HJCT)



New improved higher load capacity joist hangers. The increased thickness of the S/HJCT increases the allowable load capacity to use with joists. Joist can be attached from either side or doubled up. This hanger can be used with either steel or wood headers.

MATERIAL: S/HJCT – 12 ga (97 mil) 50ksi

FINISH: Galvanized – G90

INSTALLATION:

- Attach hanger with specified fasteners.
- Use round holes for minimum load, use round and triangle holes for maximum load.
- May be used for weld-on applications. The minimum required weld to the top flange is 1/8" x 2-1/2" fillet weld to each side of top flange. Consult the code for special considerations when welding galvanized steel.

FEATURES:

- Uni-directional: Joist can be attached from left or right.
- One size fits joists 8" through 14" deep.
- Optional holes for additional load capacity.
- Simplicity of design.
- Quick and easy installation.
- Field skewable up to 45 degrees left or right.
- Backing in steel beam cavity is not required behind the hanger.

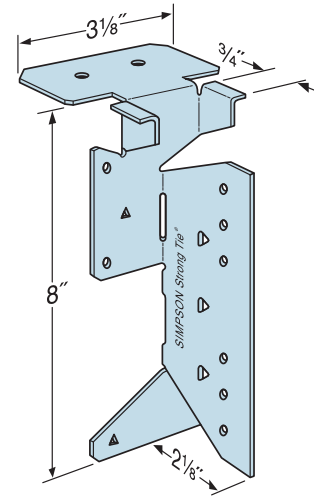

S/HJCT

Model No.	Screws		Joist	Allowable Load ^{1,2}	
	Steel Header			Uplift (100)	Down (100)
	Top	Face			
Steel Header: Straight Hanger					
S/HJCT (min)	2 -#10	4 -#14	6 -#14	1510	2920
S/HJCT (max)	2 -#10	8 -#14	9 -#14	1670	3855
Steel Header: Skewed Hanger					
S/HJCT (min)	2 -#10	4 -#14	6 -#14	1510	2305
Welded to Steel Beam – Straight Hanger					
S/HJCT (min)	1/8" x 2-1/2" fillet weld to each side of top flange		4 -#14	–	1450
Attached to Masonry – Straight Hanger					
S/HJCT (min)	2 – 1/4" x 2-1/4" Titen	4 – 1/4" x 2-1/4" Titen	6 -#14	710	1785

Notes:

1. Allowable loads for CFS headers are based on a single 54 mil (16ga) steel.
2. Steel header must be braced to prevent web buckling per designer specification.
3. Steel joist shall be laterally braced per Designer specification.
4. Screws shall be installed using joist hanger holes screwing through the hanger into the joist.
5. Tabulated loads may not be increased.
6. For joists with up to a 0.50" gap (short cut) use an adjustment factor of 0.87.
7. For joists with a 0.50" to 0.90" gap (short cut) use an adjustment factor of 0.75.

Joist Framing Connectors

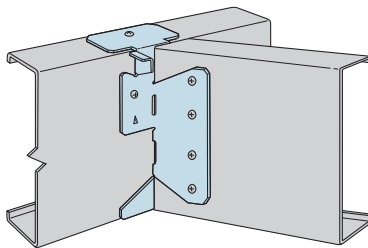

S/HJCT Skewed 45 Degrees Installation

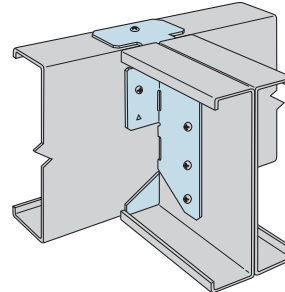

S/HJCT Double Joist Installation

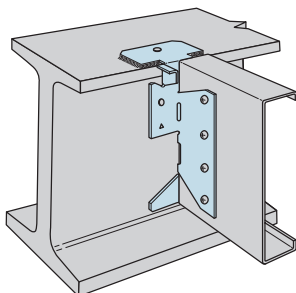

S/HJCT Weld-On Installation with an I-Beam.

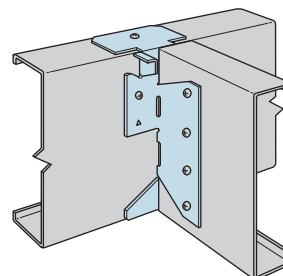

S/HJCT Installation With a CFS Steel Header

BRIDGERITE CLIP (BR)

BridgeRite Clips are ready to use to attach cold rolled channel to wall studs. This easy to use clip will save time and money from having to cut longer length angles down to size.

MATERIAL: 16 ga (54) 50ksi

FINISH: Galvanized – G90

INSTALLATION:

- Attach BridgeRite clip to web of stud and cold rolled channel #10 - 16 screws through pre-punched holes.

Model No.	Size	Box Quantity
BRC3	3-5/8", 4"	100
BRC6	6", 8"	100

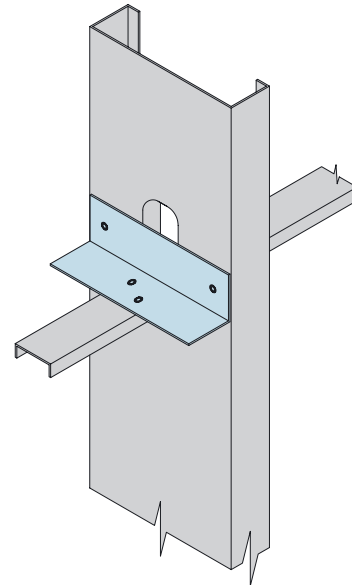
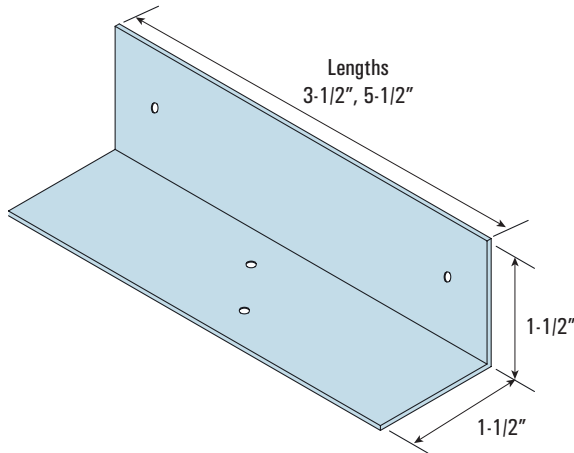

COILED STRAP (CS)



CS are continuous utility straps which can be cut to length on the job site. Packaged in lightweight (about 40 pounds) cartons.

FINISH: Galvanized – G90

INSTALLATION:

- Use all specified fasteners.
- Refer to the applicable code for minimum edge and end distances.
- The table shows the maximum allowable loads and the screws required to obtain them. See footnote #1. Fewer screws may be used; reduce the allowable load by the code lateral load for each fastener subtracted from each end.

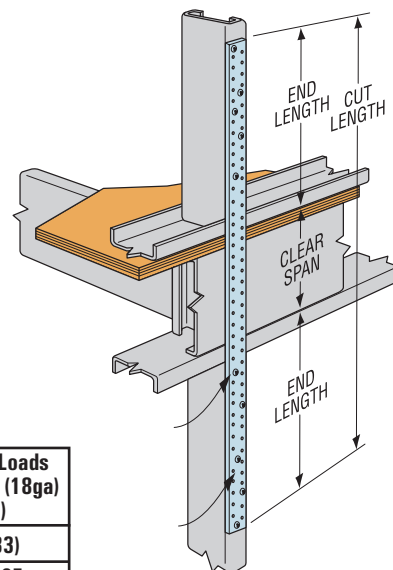
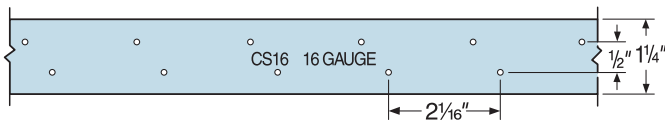

Typical CS installation as a floor-to-floor tie

Model No.	Length	Material Thickness (mil/ga)	Width	Fasteners (Total)			Allowable Tension Loads	
				Rafter/Stud/Joist Thickness			33 mil (20ga), 43 mil (18ga) & 54 mil (16ga)	
				33 mil (20ga)	43 mil (18ga)	54 mil (16ga)	(100)	(133)
CS16	150'	54 (16ga)	1-1/4"	18 -#10	12 -#10	8 -#10	1550	2065
CS18	200'	43 (18ga)	1-1/4"	14 -#10	10 -#10	6 -#10	1235	1645
CS20	250'	33 (20ga)	1-1/4"	12 -#10	8 -#10	6 -#10	945	1260

Notes:

1. Use half of the fasteners in each member being connected to achieve the listed loads.
2. For CS straps: End Length (inches) = 1/2 total fasteners + 1".
3. Total Cut Length = End Length + Clear Span + End Length.
4. For a reduced number of screws, allowable load = (#screws used/#screws in table) x table load.
5. Loads are based on lesser of steel strap capacity and 2001 AISI NASPEC fastener calculation.
6. Tabulated loads shown at (100) do not include steel stress increase. Tabulated loads shown at (133) include a 1/3 stress increase on the steel.

KATZ BLOCKING (KB)

Katz Blocking has been designed to provide top of wall attachment between parallel framing members. Product is pre-punched to work in 16" and 24" spacing of parallel framing members of wood or steel.

MATERIAL: See Table. 18 ga (43 mil) 33ksi; 20 ga (30 mil) 33ksi; 25 ga (18 mil) 33ksi

FINISH: Galvanized – G40

INSTALLATION:

- Insert the pre-cut structural blocking to fit securely between the underside of the floor/ceiling joist or roof trusses.
- Using #8 minimum self-drilling screws secure the blocking to steel framing of #8d nail to wood framing using the pre-punched holes.
- Use Katz blocking at 4' o.c. or maximum specified.

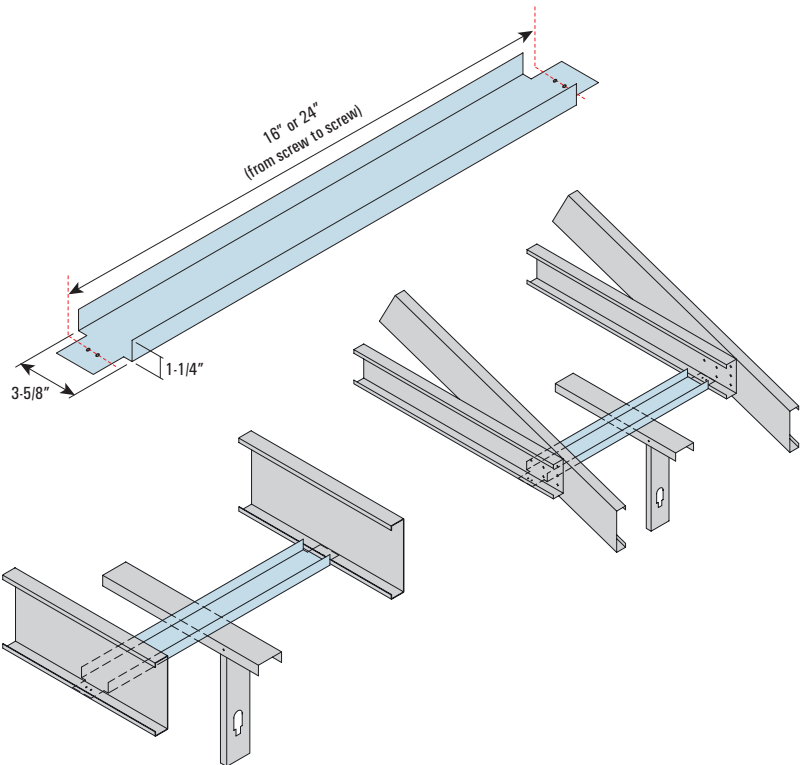

Model No.	Length	Gauge	Size	Pallet Qty
KATZ16	16"	25	3-5/8"	500
KATZ24	24"	25	3-5/8"	500
KATZ2024	24"	20	3-5/8"	500
KATZ1816	16"	18	3-5/8"	200
KATZ1824	24"	18	3-5/8"	200

TENSION BRIDGING (TB)



TB bridging is a cost effective way to provide bracing between floor joists when compared with field fabricated blocking and clip angles with multiple fasteners. TB is a tension-type bridging with maximum fastener flexibility. Use two #10 screws of the seven screw holes at each end.

MATERIAL: 20 ga (33) 50ksi

FINISH: Galvanized – G90

INSTALLATION:

- Bridging will fit flange widths from 1-5/8" to 3"

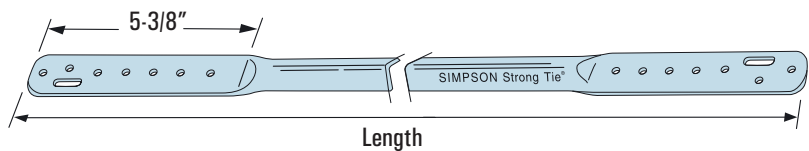

Model No.	Length	Web Heights	Spacing (o.c.)
TB20	20"	6"	12"
TB20	20"	8"	12"
TB20	20"	10"	12"
TB27	27"	12"	12"
TB27	27"	6"	16"
TB27	27"	8"	16"
TB27	27"	10"	16"
TB27	27"	12"	16"
TB36	36"	10"	24"
TB36	36"	12"	24"

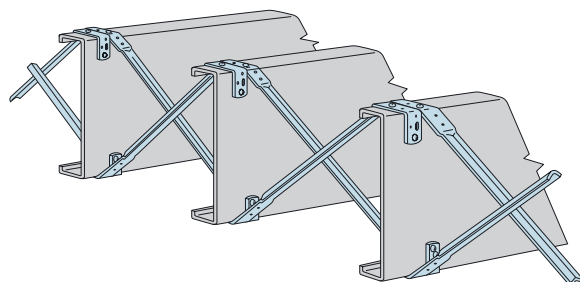

BREAKAWAY CLIP (BA)

Breakaway Clips are manufactured from aluminum and designed to melt under extreme heat allowing a fire damaged structure to collapse while permitting the fire wall to remain in place to protect adjacent units.

MATERIAL: Aluminum .063"

INSTALLATION:

- Must be used in conjunction with Area Separation Wall Systems.
- Attach the Breakaway Clip to the completed Area Separation Wall Assembly.
- One Clip should be located at each side of each H Stud.
- Fasten BA Clip to H Stud with a screw through pre-punched holes.
- Attach to wood or steel adjacent framing with nails or screws respectively.

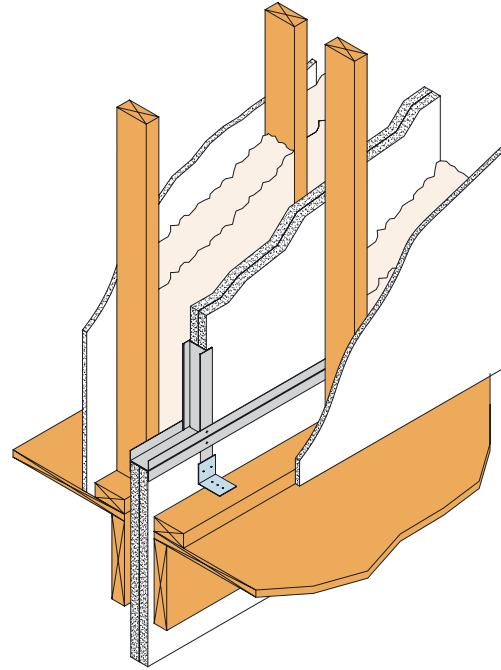
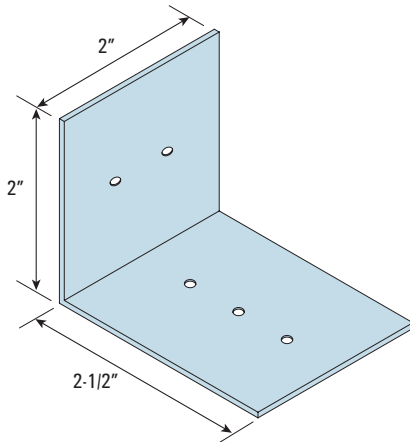

GROMMET

Grommets snap easily into stud and joist knockouts. They are used to protect electrical wiring and plumbing lines from contacting metal. Grommets can be used in commercial and residential construction for stud sizes of 3-1/2" and larger.

INSTALLATION:

- Install grommets in all stud knockouts where wiring and plumbing lines will be inserted.
- Simple one piece snap in installation.
- 25 parts to a bag/500 to a box.

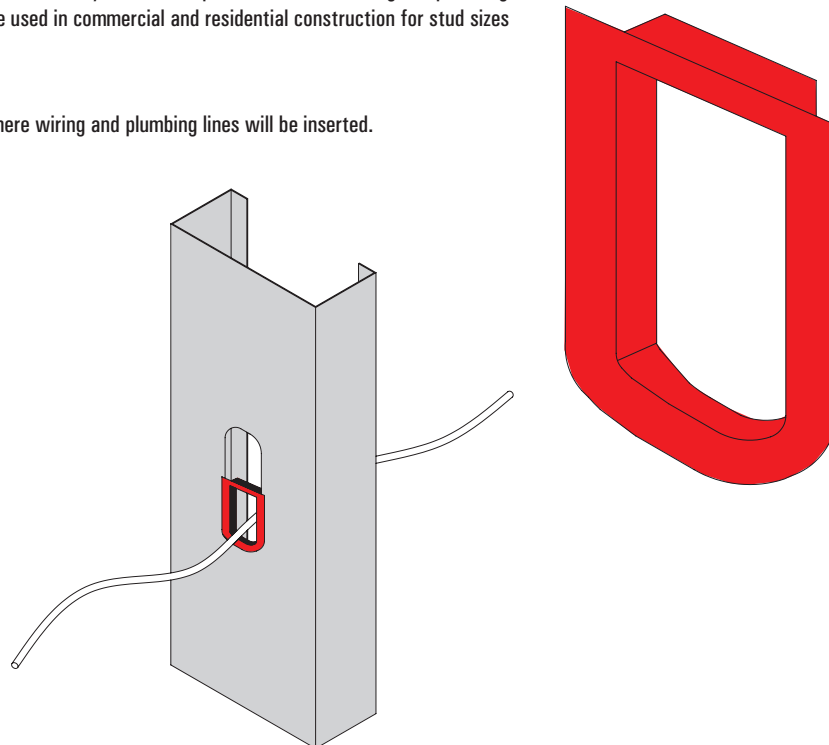

U-FLEX TRACK

U-Flex is a flexible steel track whose main feature is its great flexibility in every direction, both horizontally and vertically. It was designed for curved steel and wood framing and works great for walls, ceilings, arches, columns, etc. U-Flex easily adapts to all types of curves. U-Flex fits together to create identical shapes and is simple, fast, economical and professional.

INSTALLATION:

It's so easy to apply. It's a valuable time-saver. It's the assurance of doing a complex job. It's the satisfaction of a job well done. No more headaches or complicated calculations. No more of the arduous and often inaccurate work performed by the metallic scissors. No more doubt or hesitation when faced with a curved-surface project.

Model No.	Web	Leg	Minimum Radius	Radius with Cut	Gauge (mil)
212UFT2508	2-1/2"	1-11/32"	5-1/4"	2-3/4"	25 (.018)
358UFT2508	3-5/8"	1-11/32"	8-1/4"	4-3/4"	25 (.018)
358UFT2008	3-5/8"	1-11/32"	8-1/4"	4-3/4"	20 (.033)
600UFT2008	6"	1-3/4"	24"	16"	20 (.033)

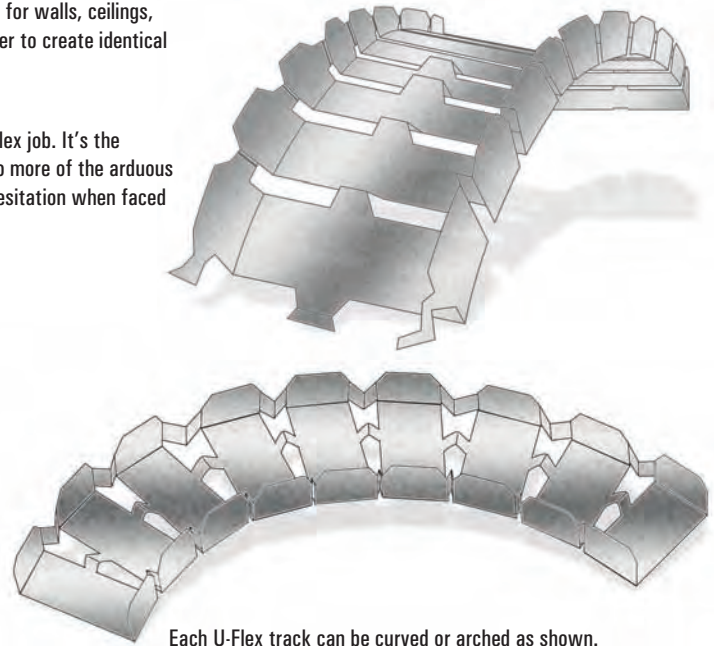

Each U-Flex track can be curved or arched as shown.

RESILMOUNT SOUND ISOLATION CLIP

NEW

Acoustic control for airborne sound has become a major issue for architects and interior designers for high density apartment living, condos, townhouses, studios and theaters. Resilmount's range of resilient mounts fit standard furring channels for effective noise control. Resilient mount clips are the most effective acoustic control system, as they isolate the system from the building structure.

INSTALLATION:

- Maximum dead load 55lbs each clip
- Maximum spacing of clip is 4' on center
- Screws and masonry sleeve anchors recommended for all attachments (See fasteners manufacturers specifications)
- Suitable for use with 7/8" and 1-1/2" furring channels
- Tested to achieve a rating of STC 63 per ASTM E90
Test numbers TL08-240 and TL08-239 by Riverbank Acoustical Laboratories
- Patents pending

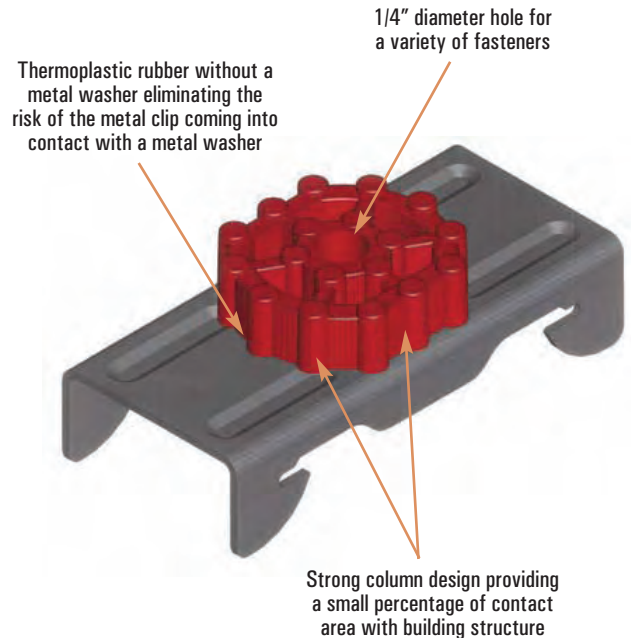
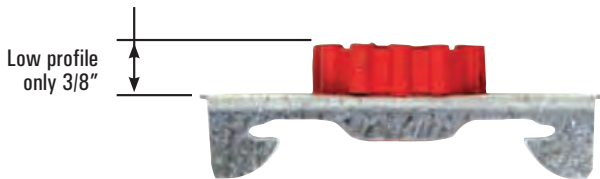

Specialty Products



Warranty & Limitations

All products presented herein are warranted to the buyer to be free from defects in material and workmanship. The foregoing warranty is non-assignable and in lieu of and excludes all other warranties not expressly set forth herein, whether express or implied by operation of law or otherwise, including but not limited to any implied warranties of merchantability or fitness for a particular purpose. All details and specifications presented herein are intended as a general guide for the use of MarinoWARE® framing systems. These products should not be used without evaluation by a qualified engineer or architect to determine their suitability for a specific use.

MarinoWARE® assumes no responsibility for failure resulting from use of its details or specifications, or for failure resulting from improper application or installation of these products.

Governing Law

All issues arising in connection with your order and all transactions associated with it shall be interpreted according to the laws of the State of New Jersey, and all actions or other proceedings arising out of such issues shall be brought only in Superior Court, State of New Jersey, County of Essex, or United States District Court for the District of New Jersey. No action may be brought more than one year after accrual of the cause of action therefore.



www.MarinoWARE.com

For more information, please contact MarinoWARE® Technical Services at 866-545-1545.

This technical information reflects the most current information available and supersedes any and all previous publications effective May 21, 2009. #FRC2-5/2009

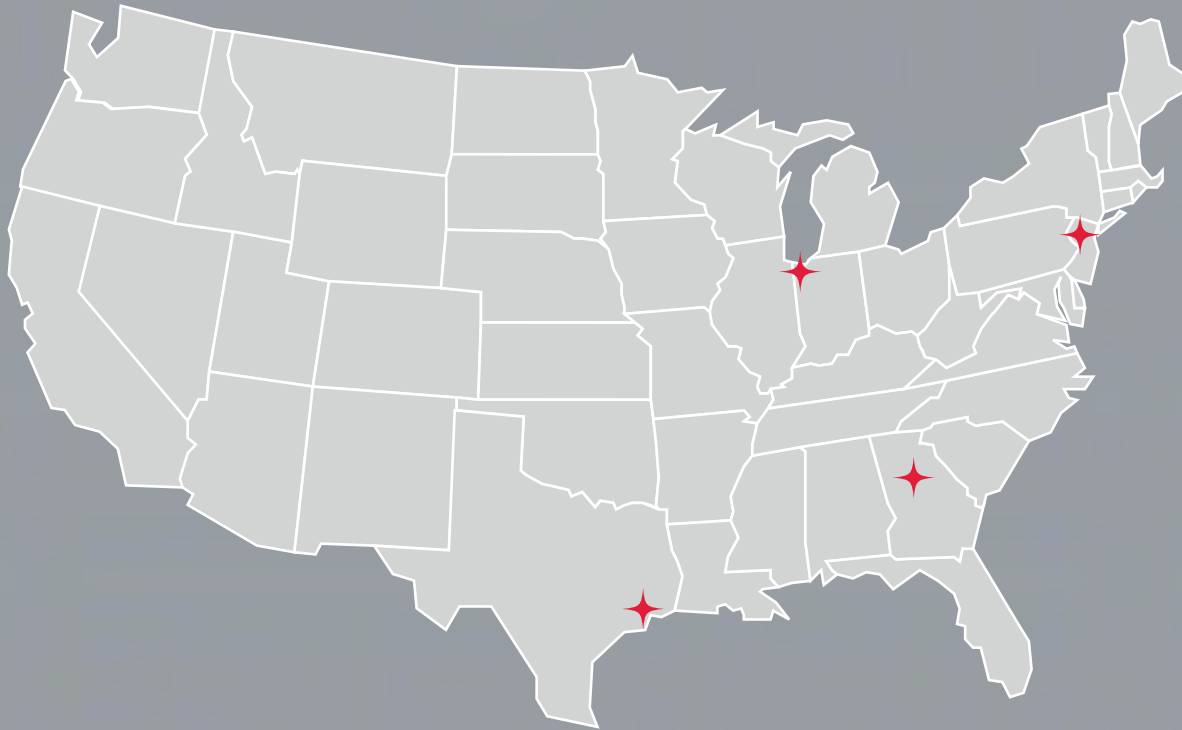

MARINO WARE®

★ **MarinoWARE®**
New Jersey Plant
400 Metuchen Rd.
South Plainfield, NJ 07080
P: 800.627.4661
F: 908.412.1442

★ **MarinoWARE®**
Georgia Plant
777 Greenbelt Pkwy.
Griffin, GA 30223
P: 800.504.8199
F: 678.688.1379

★ **MarinoWARE®**
Indiana Plant
4245 Railroad Ave.
East Chicago, IN 46312
P: 219.378.7100
F: 219.378.7106

★ **MarinoWARE®**
Texas Plant
10101 Bay Area Blvd.
Pasadena, TX 77507
P: 800.504.8199
F: 281.283.8105

★ **MarinoWARE®**
New York Sales Office
134 Broadway, Ste. C
Amityville, NY 11701
P: 800.627.4667
F: 631.691.1492

★ **MarinoWARE®**
Engineering Office
200 Business Center Drive
Stockbridge, GA 30281
P: 866-545-1545
F: 770.507.2605

www.MarinoWARE.com

For more information, please contact MarinoWARE® Technical Services at 866-545-1545

This technical information reflects the most current information available and supersedes any and all previous publications effective May 12, 2011. #FRC2-5/2011