



SOUND SOLUTIONS
Solutions Catalog



SOUND SOLUTIONS GUIDE





**Image above showcases SoundGuard® by MarinoWARE*

TECHNICAL SERVICES + SUPPORT | **DesignGroup™**

Our commitment to quality products extends to best-in-class design support. The MarinoWARE® DesignGroup™ offers a full range of technical support and engineering services, including professionally engineered stamped shop drawings, design and installation assistance on all MarinoWARE manufactured products, and expert advice on structural, nonstructural, fire and acoustic assemblies.

If you have questions or need more information on any of the products listed in this catalog, contact our Technical Services department at technicalservices@marinoware.com, or at 866.545.1545. In most cases Technical Services representatives can provide an immediate response.

Warranty & Limitations

All products presented herein are warranted to the buyer to be free from defects in material and workmanship. The foregoing warranty is non-assignable and in lieu of and excludes all other warranties not expressly set forth herein, whether express or implied by operation of law or otherwise, including but not limited to any implied warranties of merchantability or fitness for a particular purpose. All details and specifications presented herein are intended as a general guide for the use of MarinoWARE® framing systems. These products should not be used without evaluation by a qualified engineer or architect to determine their suitability for a specific use.

MarinoWARE® assumes no responsibility for failure resulting from use of its details or specifications, or for failure resulting from improper application or installation of these products.

Governing Law

All issues arising in connection with your order and all transactions associated with it shall be interpreted according to the laws of the State of New Jersey, and all actions or other proceedings arising out of such issues shall be brought only in Superior Court, State of New Jersey, County of Essex, or United States District Court for the District of New Jersey. No action may be brought more than one year after accrual of the cause of action therefore.

Table of Contents **of Sound Tested Assemblies**

StudRite®	6
SoundGuard®	7
Sure-Board® Floor	9
Sure-Board® Wall	11
ViperStud®	13
RC-MAX®	15
Firestopping	17
GenieClip®	23
Shaftwall.....	26
JoistRite®	27

This guide represents a compilation of MarinoWARE sound tested assemblies, always verify UL or other Listed fire-rated designs for additional requirements.

The Basics of Sound Isolation in Construction

Sound isolation in construction involves the use of various materials and techniques to minimize the transmission of sound from one space to another. Some common strategies for achieving sound isolation include using resilient channels, sound-absorbing materials, and sound-blocking materials.

Resilient channels are thin metal channels that are installed between the framing and drywall of a wall or ceiling. They create a separation between the two layers of drywall, which helps to reduce the transmission of sound vibrations between rooms. The channels work by allowing the outer layer of drywall to vibrate independently of the framing, which helps to dissipate sound energy.

Sound-absorbing materials such as fiberglass insulation and acoustic panels can also be used to help reduce the transmission of sound. These materials work by absorbing sound energy rather than reflecting it back into the room. When placed within walls or ceilings, they can help to reduce the amount of sound that passes through the structure.

Sound-blocking materials such as gypsum board can also be used to reduce sound transmission. Gypsum board is dense, which helps to block the transmission of sound waves. When used in combination with other sound isolation techniques, they can help to create a more acoustically isolated space.

There are also several construction techniques that can be used to help achieve sound isolation, such as staggered stud walls and double-layered walls. Staggered stud walls involve alternating the placement of studs on opposite sides of a wall, which helps to reduce the direct transmission of sound between rooms. Double-layered walls involve the use of two layers of drywall separated by a layer of sound-absorbing insulation, which helps to reduce both airborne and impact noise transmission.

Primary Methods for Reducing Sound Transfer

There are three primary methods of reducing sound transfer in buildings: increasing mass, decoupling, and using sound-dampening products.

Increasing Mass: Adding mass to walls, ceilings, and floors is a highly effective way to reduce sound transfer. This is because heavier materials are better able to absorb and block sound waves. Common materials used for this purpose include concrete, brick, and heavy-duty drywall. According to the National Institute of Standards and Technology (NIST), “the effectiveness of mass in blocking sound is proportional to the square of its thickness” (NIST, 2010).

Decoupling: Decoupling involves separating two surfaces to prevent sound waves from traveling through them. This is typically achieved by creating a “floating” structure, in which walls or ceilings are not directly connected to the building’s structure. This can be accomplished through the use of resilient channels, spring isolators or decoupled steel framing. Resilient channels, for example, are thin metal channels that are installed between the framing and drywall of a wall or ceiling. They create a separation between the two layers of drywall, which helps to reduce the transmission of sound vibrations between rooms. An example of decoupled steel framing is the SoundGuard Steel Framing System.

Sound-Dampening Products: Sound-dampening products are materials that are designed to absorb sound waves and prevent them from bouncing around a room. These products are typically made from materials like fiberglass, foam, or cork, and are often used in conjunction with other sound-reducing methods like mass and decoupling. Sound-dampening products can be applied to walls, ceilings, and floors to help reduce the amount of sound that enters or exits a room.

The importance of ASTM E90 for sound solutions

ASTM E90 is a standard test method used to measure airborne sound transmission loss through building partitions. The test involves measuring the sound intensity levels on either side of a partition and determining the difference between the two. The results are then used to calculate the sound transmission class (STC) rating of the partition.

The ASTM E90 standard has been widely adopted by the construction industry as a means of quantifying the acoustic performance of building partitions. It is frequently used in the design and construction of buildings where acoustic privacy and sound isolation are important considerations, such as hospitals, schools, and office buildings.

One example of the use of ASTM E90 in the construction industry can be seen in the LEED (Leadership in Energy and Environmental Design) certification process. LEED certification is a globally recognized rating system that measures the environmental sustainability of buildings. One of the requirements for LEED certification is that buildings must meet certain acoustic performance standards, including a minimum STC rating for building partitions. ASTM E90 is one of the approved test methods for measuring STC ratings and is commonly used to demonstrate compliance with LEED requirements.

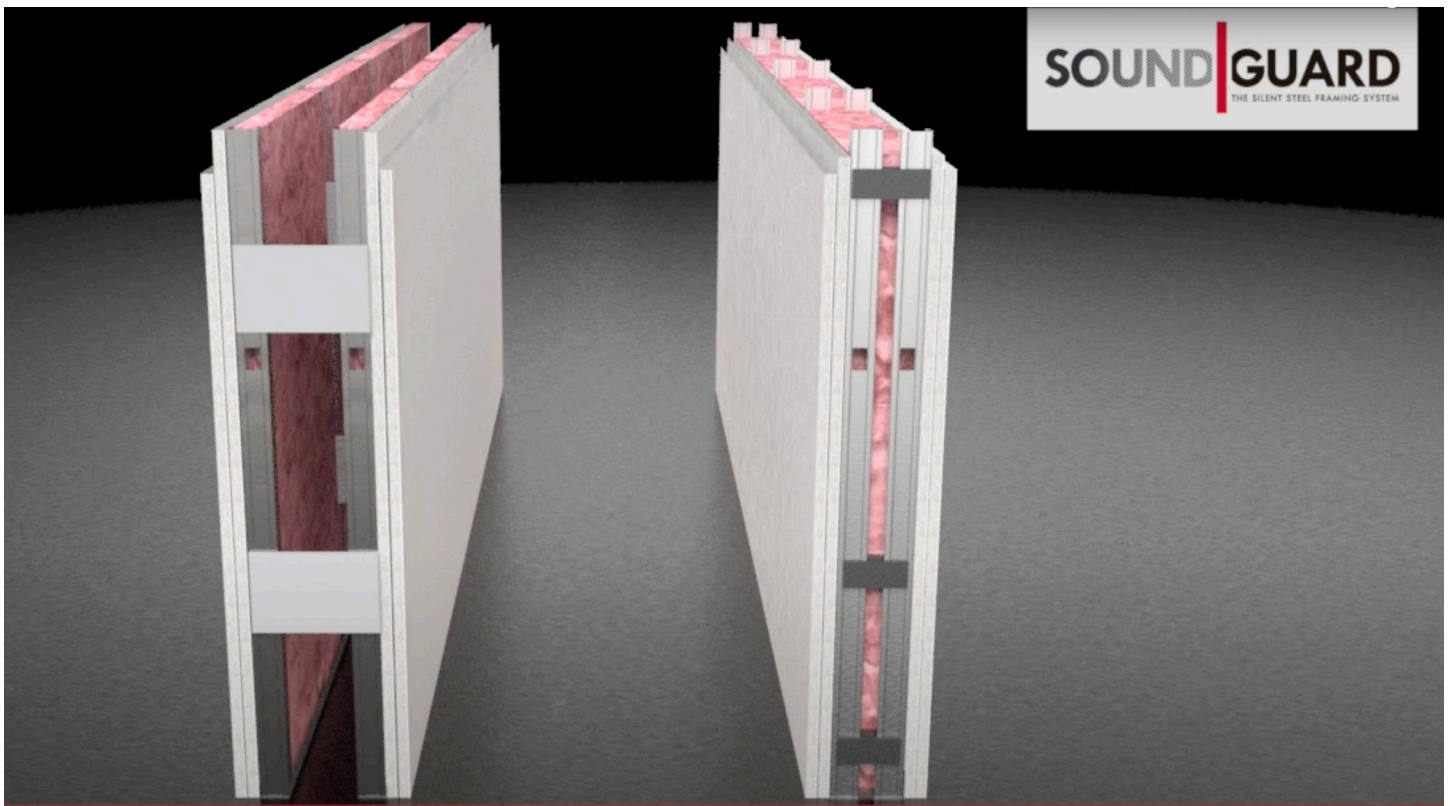

**Image above, illustration on the right showcases SoundGuard® by MarinoWARE*

Sources:

American Society of Interior Designers. (2014). Sound isolation in construction. <https://www.asid.org/resources/sound-isolation-construction> Building Science Corporation. (2010). Acoustical isolation. <https://www.buildingscience.com/documents/information-sheets/info-sheet-acoustical-isolation> National Institute of Building Sciences. (2015). Sound isolation. <https://www.wbdg.org/design-objectives/sound-isolation>

National Institute of Standards and Technology (NIST). (2010). How to soundproof a room. https://www.nist.gov/system/files/documents/el/building_materials_soundproofing.pdf American Society of Interior Designers. (2014). Sound isolation in construction. <https://www.asid.org/resources/sound-isolation-construction> Building Science Corporation. (2010). Acoustical isolation. <https://www.buildingscience.com/documents/information-sheets/info-sheet-acoustical-isolation>

StudRite is a steel framing stud that utilizes continuous lip reinforced triangular knockouts. The large knockouts help reduce noise transmission and make for an effecting sound solution.

3-5/8" StudRite® (18mil) 24" O.C.

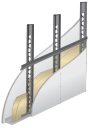
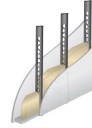
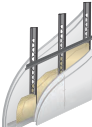

STC Rating

 <p>Wall Type A</p>	<ul style="list-style-type: none"> • Fiberglass insulation • RC-Max resilient channel 1 side • 1 layer of 5/8" type X GWB, each side 	<p style="text-align: center;">52</p> <p style="text-align: right;">TR: 2015113</p>
 <p>Wall Type B</p>	<ul style="list-style-type: none"> • Fiberglass insulation • 1 layer of 5/8" type X GWB, each side 	<p style="text-align: center;">44</p> <p style="text-align: right;">TR: 2016028</p>
 <p>Wall Type C</p>	<ul style="list-style-type: none"> • Fiberglass insulation • RC-Max resilient channel 1 side • 2 layers of 5/8" type X GWB, each side 	<p style="text-align: center;">61</p> <p style="text-align: right;">TR: 2015114</p>

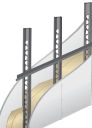
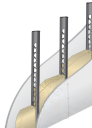
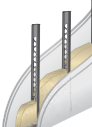
3-5/8" StudRite® (18mil) 16" O.C.

 <p>Wall Type A</p>	<ul style="list-style-type: none"> • Fiberglass insulation • RC-Max resilient channel, 1 side • 1 layer 5/8" type X GWB, each side 	<p style="text-align: center;">52</p> <p style="text-align: right;">TR: 2015115</p>
 <p>Wall Type B</p>	<ul style="list-style-type: none"> • Fiberglass insulation • 1 layer of 5/8" type X GWB, each side 	<p style="text-align: center;">47</p> <p style="text-align: right;">TR: 2016029</p>
 <p>Wall Type E</p>	<ul style="list-style-type: none"> • Fiberglass insulation • 2 layers of 5/8" type X GWB, each side 	<p style="text-align: center;">54</p> <p style="text-align: right;">TR: 2016030</p>

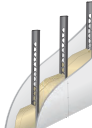
3-5/8" StudRite® (30mil) 16" O.C.

 <p>Wall Type B</p>	<ul style="list-style-type: none"> • Fiberglass insulation • 1 layer of 5/8" type X GWB, each side 	<p style="text-align: center;">40</p> <p style="text-align: right;">TR: 2015118</p>
 <p>Wall Type D</p>	<ul style="list-style-type: none"> • Fiberglass insulation • 1 layer of 5/8" type X GWB, one side • 2 layers of 5/8" type X GWB, other side 	<p style="text-align: center;">44</p> <p style="text-align: right;">TR: 2015119</p>

6" StudRite® (54mil) 16" O.C.

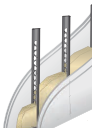
 <p>Wall Type E</p>	<ul style="list-style-type: none"> • Fiberglass insulation • 2 layers of 5/8" type X GWB, each side 	<p style="text-align: center;">43</p> <p style="text-align: right;">TR: NOAL19-0110</p>
--	---	--

SoundGuard®

SoundGuard is an acoustically decoupled steel stud. The stud is assembled in the factory using a closed cell foam isolator to create an air gap. This gap contributes to reducing sound transmission.

Single Layer 5/8" Type X GWB 1x1 Application

Wall Size	Application	STC Rating		Conventional Partition Range
		16" o.c. ²	24" o.c. ¹	
3 5/8" Wall	2-1 5/8" Studs, Single GWB each side, 3-1/2" Fiberglass Batts	51	52	50-54
4" Wall	2-1 5/8" Studs, Single GWB each side, 3-1/2" Fiberglass Batts	51	52	
6" Wall	2-2 1/2" Studs, Single GWB each side, 6-1/2" Fiberglass Batts	53	52	

1. Based on 4" Wall Testing 2. Based on 19 mil Design Thickness 3. Fiberglass or ROCKWOOL™ stone wool insulation is acceptable

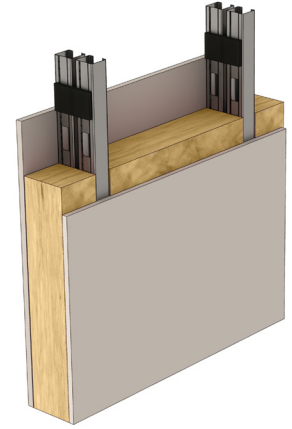

NOAL19-1001R, NOAL19-1004R, RAL-TL15-075

3 5/8" Wall with 1x1 Application

6" Wall with 1x1 Application

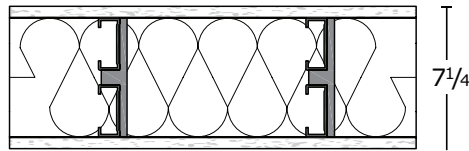
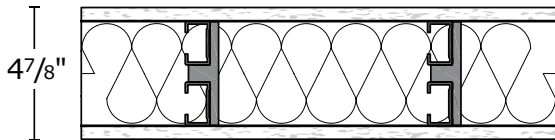

Unbalanced 5/8" Type X GWB 2x1 Application

Wall Size	Application	STC Rating		Conventional Partition Range
		16" o.c. ²	24" o.c. ¹	
3 5/8" Wall	2-1 5/8" Studs, Single GWB one side, Double GWB other side, 3-1/2" Batts Fiberglass	54	57	55-59
4" Wall	2-1 5/8" Studs, Single GWB one side, Double GWB other side, 3-1/2" Batts Fiberglass	54	57	
6" Wall	2-2 1/2" Studs, Single GWB one side, Double GWB other side, 6-1/2" Fiberglass Batts	56	57	

1. Based on 4" Wall Testing 2. Based on 19 mil Design Thickness 3. Fiberglass or ROCKWOOL™ stone wool insulation is acceptable

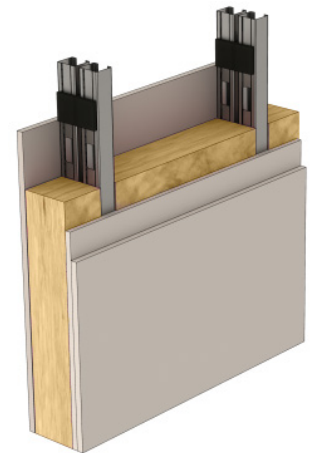

NOAL19-1002R, NOAL19-1005R, RAL-TL15-073

3 5/8" Wall with 2x1 Application

6" Wall with 2x1 Application

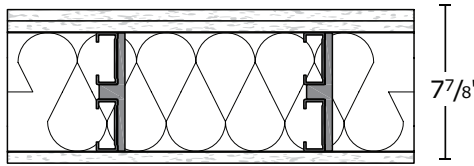
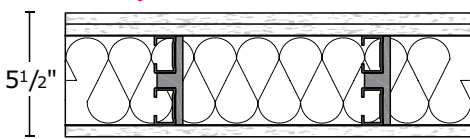

Double Layer 5/8" Type X GWB 2x2 Application

Wall Size	Application	STC Rating		Conventional Partition Range
		16" o.c. ²	24" o.c. ¹	
3 5/8" Wall	2-1 5/8" Studs, Double GWB each side, 3-1/2" Fiberglass Batts	57	60	60-64
4" Wall	2-1 5/8" Studs, Double GWB each side, 3-1/2" Fiberglass Batts	57	60	
6" Wall	2-2 1/2" Studs, Double GWB each side, 6-1/2" Fiberglass Batts	60	60	

1. Based on 4" Wall Testing 2. Based on 19 mil Design Thickness 3. Fiberglass or ROCKWOOL™ stone wool insulation is acceptable

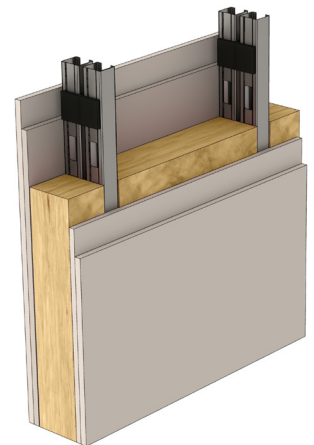

NOAL19-1003R, NOAL19-1006R, RAL-TL15-074

3 5/8" Wall with 2x2 Application

6" Wall with 2x2 Application

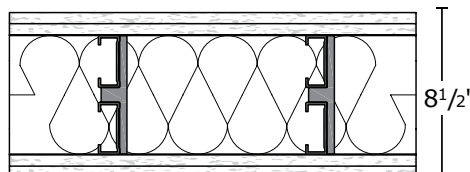
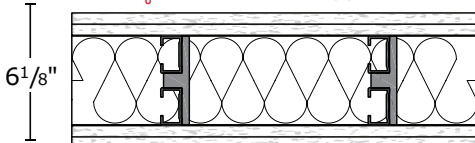

SoundGuard® Plumbing Wall

SoundGuard Plumbing Wall is an acoustically decoupled steel stud. The stud is assembled in the factory using a closed cell foam isolator to create a large air gap. This gap contributes to reducing sound transmission and is large enough to accommodate a 2-3/4" pipe.

Single Layer 5/8" Type X GWB 1x1 Application

Wall Size	Application	STC Rating 16" o.c. ²	Conventional Partition Range
6" Plumbing	2 - 1 5/8" Studs, Single GWB each side, R-13 Insulation, 2 3/4" cavity	53	50-54

1. Based on 6" Wall Testing 2. Based on 19 mil Design Thickness 3. Fiberglass or ROCKWOOL™ stone wool insulation is acceptable

6" Wall with 1x1 Application

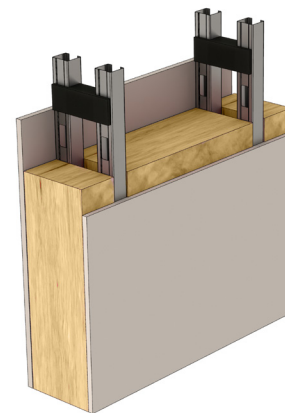
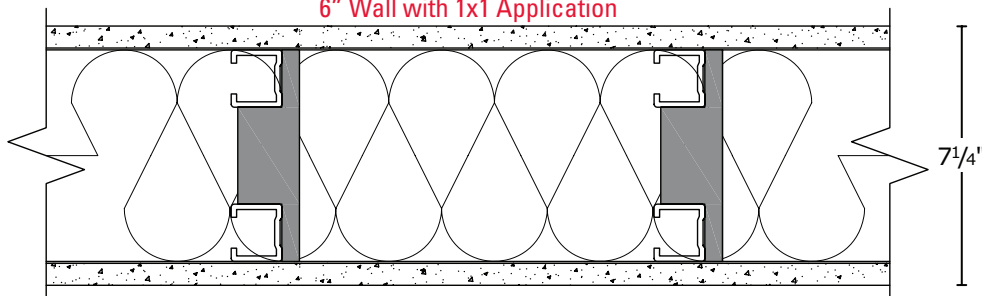

NOAL19-1004R

Unbalanced 5/8" Type X GWB 2x1 Application

Wall Size	Application	STC Rating 16" o.c. ²	Conventional Partition Range
6" Plumbing	2 - 1 5/8" Studs, Single GWB one side, Double GWB other side, R-13 Insulation, 2 3/4" cavity	56	55-59

1. Based on 6" Wall Testing 2. Based on 19 mil Design Thickness 3. Fiberglass or ROCKWOOL™ stone wool insulation is acceptable

6" Wall with 2x1 Application

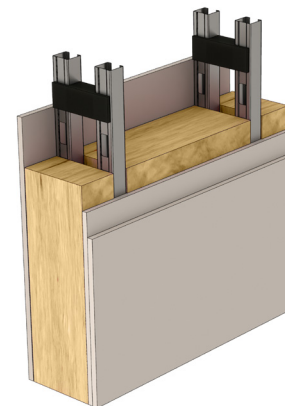
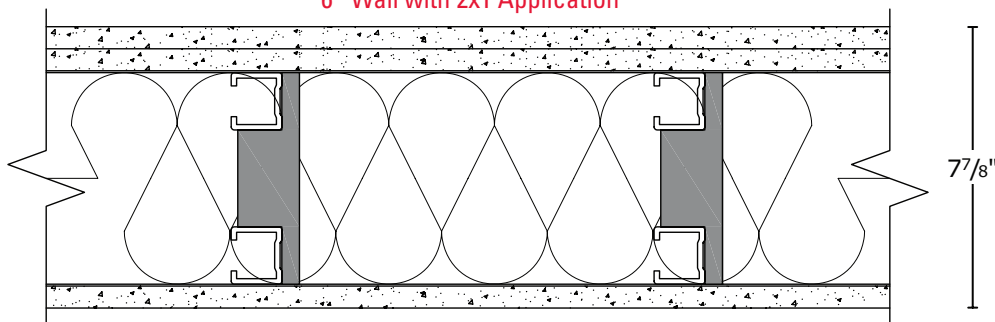

NOAL19-1005R

Double Layer 5/8" Type X GWB 2x2 Application

Wall Size	Application	STC Rating 16" o.c. ²	Conventional Partition Range
6" Plumbing	2 - 1 5/8" Studs, Double GWB each side, R-13 Insulation, 2 3/4" cavity	60	60-64

1. Based on 6" Wall Testing 2. Based on 19 mil Design Thickness 3. Fiberglass or ROCKWOOL™ stone wool insulation is acceptable

6" Wall with 2x2 Application

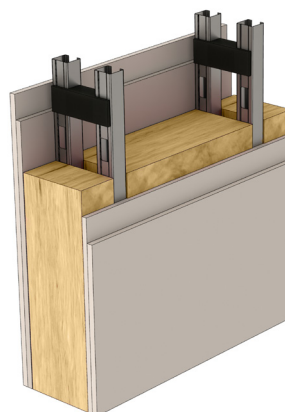
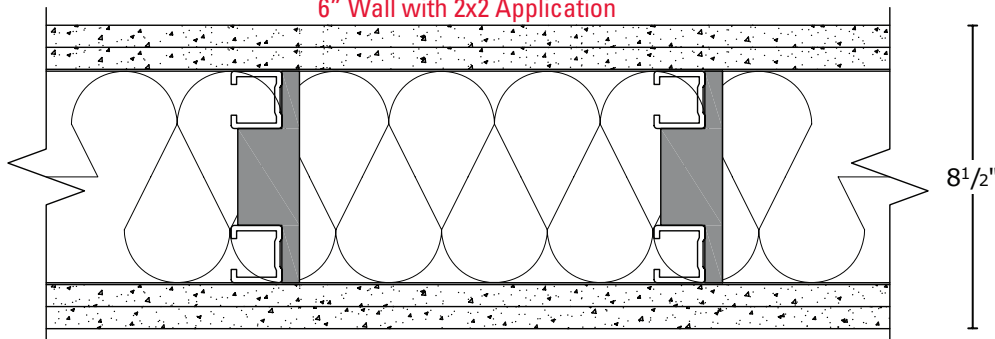

NOAL19-1006R

Sure-Board® Floor

Sure-Board Floor is a composite underlayment floor sheathing utilizing a structural 3/4" substrate laminated to 33 mil steel sheet. The floor sheathing offers high load values and is tested in multiple configurations for sound transmission.

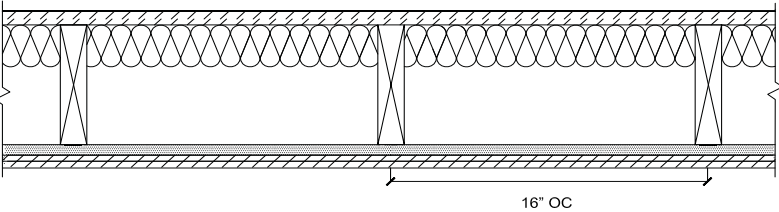
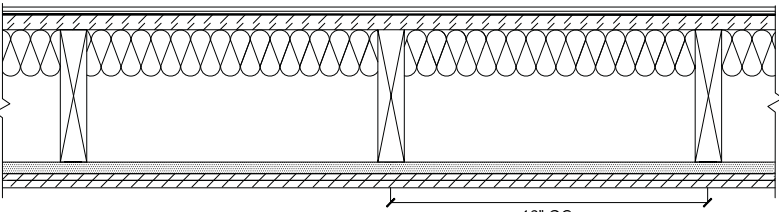
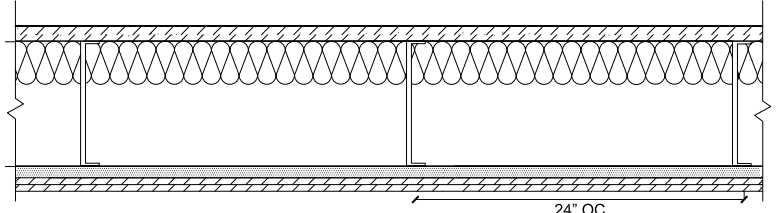
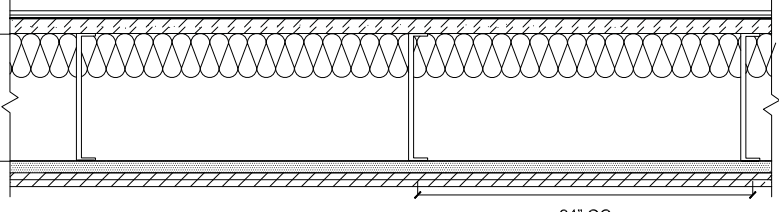
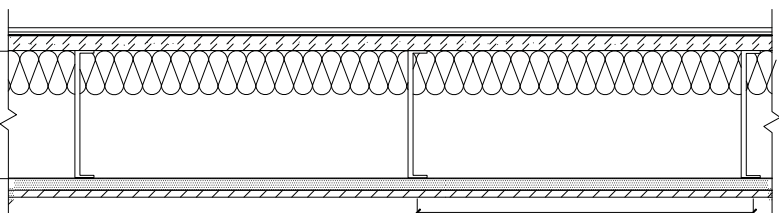
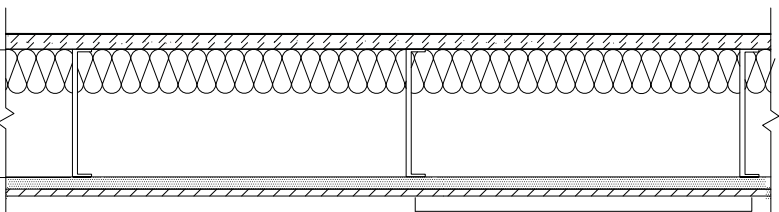
Floor/Ceiling Assemblies	Descriptions	STC/IIC Rating
 <p>16" OC</p>	<ul style="list-style-type: none"> • 3/4" Sureboard 200S • 1 5/8" Self-piercing screws at 6'-0" o.c. • 6 1/4" R19 Fiberglass Insulation • 2x10" WOOD JOIST • RC1 at 24" o.c. • 2 layers 5/8" Type C Gypsum Wallboard 	<p>60/47</p> <p>OL15-1018</p>
 <p>16" OC</p>	<ul style="list-style-type: none"> • 3/4" Carpet • 1/2" Carpet Pad • 3/4" Sureboard 200S • 1 5/8" Self-piercing screws at 6'-0" o.c. • 6 1/4" R19 Fiberglass Insulation • 2x10" WOOD JOIST • RC1 at 24" o.c. • 2 layers 5/8" Type C Gypsum Wallboard 	<p>61/74</p> <p>OL15-1019</p>
 <p>24" OC</p>	<ul style="list-style-type: none"> • 3/4" Sureboard 200S • 1 5/8" Self-piercing screws at 6'-0" o.c. • 6 1/4" R19 Fiberglass Insulation • 10" 16ga. Steel Joist • RC1 at 24" o.c. • 2 layers 5/8" Type C Gypsum Wallboard 	<p>61/41</p> <p>OL16-0201</p>
 <p>24" OC</p>	<ul style="list-style-type: none"> • 3/4" Carpet • 1/2" Carpet Pad • 3/4" Sureboard 200S • 1 5/8" Self-piercing screws at 6'-0" o.c. • 6 1/4" R19 Fiberglass Insulation • 10" 16ga. Steel Joist • RC1 at 24" o.c. • 2 layers 5/8" Type C Gypsum Wallboard 	<p>61/78</p> <p>OL16-0202</p>
 <p>24" OC</p>	<ul style="list-style-type: none"> • 3/4" Carpet • 1/2" Carpet Pad • 3/4" Sureboard 200S • 1 5/8" Self-piercing screws at 6'-0" o.c. • 6 1/4" R19 Fiberglass Insulation • 10" 16ga. Steel Joist • RC1 at 24" o.c. • 1 layer 5/8" Type C Gypsum Wallboard 	<p>59/74</p> <p>OL16-0203</p>
 <p>24" OC</p>	<ul style="list-style-type: none"> • 3/4" Sureboard 200S • 1 5/8" Self-piercing screws at 6'-0" o.c. • 6 1/4" R19 Fiberglass Insulation • 10" 16ga. Steel joist • RC1 at 24" o.c. • 1 layer 5/8" Type C Gypsum Wallboard 	<p>58/35</p> <p>OL16-0204</p>

* Information used with permission from International Materials®, Inc. MarinoWARE® is a licensed partner.

Sure-Board® Floor

Floor/Ceiling Assemblies

Descriptions

STC/IIC Rating

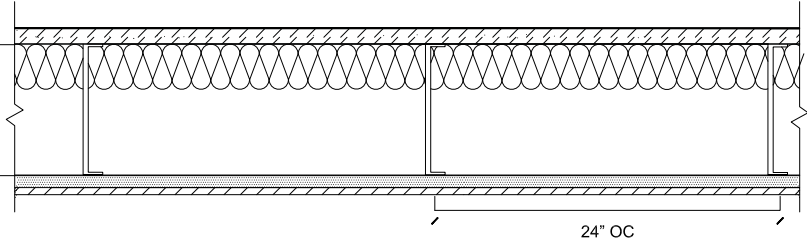
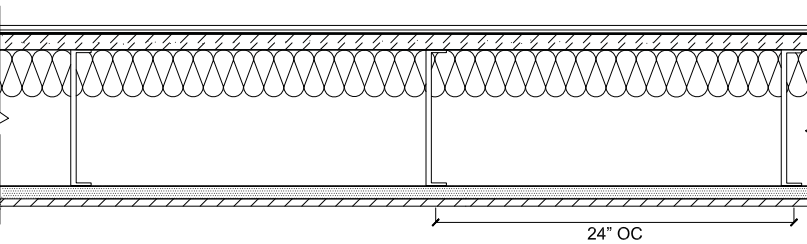
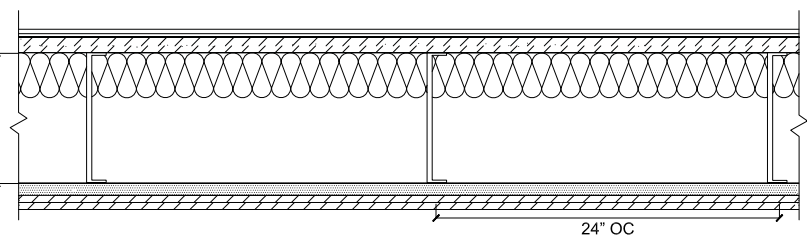
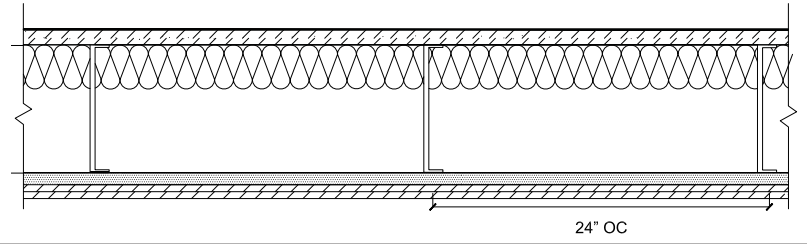
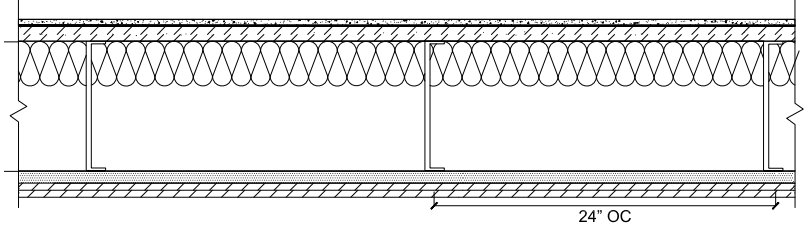
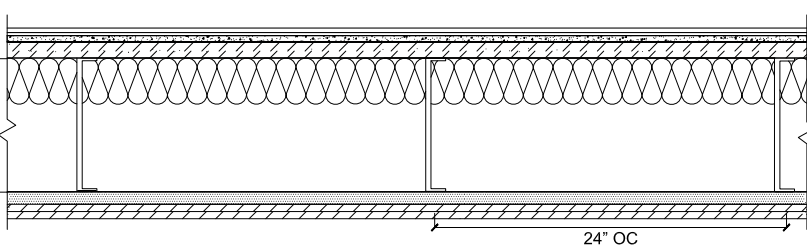
 <p style="text-align: center;">24" OC</p>	<ul style="list-style-type: none"> • 3/4" Sureboard 200S • 1 5/8" Self-piercing screws at 6'-0" o.c. • 6 1/4" R19 Fiberglass Insulation • 10" 16ga. Steel Joist • RC1 at 24" o.c. • 5/8" Type C Gypsum Wallboard 	<p>57/31</p> <p style="text-align: right;">OL16-0205</p>
 <p style="text-align: center;">24" OC</p>	<ul style="list-style-type: none"> • 3/4" Carpet • 1/2" Carpet Pad • 3/4" Sureboard 200S • 1 5/8" Self-piercing screws at 6'-0" o.c. • 6 1/4" R19 Fiberglass Insulation • 10" 16ga. Steel Joist • RC1 at 24" o.c. • 5/8" Type C Gypsum Wallboard 	<p>58/74</p> <p style="text-align: right;">OL16-0206</p>
 <p style="text-align: center;">24" OC</p>	<ul style="list-style-type: none"> • 3/4" Carpet • 1/2" Carpet Pad • 3/4" Sureboard 200S • 1 5/8" Self-piercing screws at 6'-0" o.c. • 6 1/4" R19 Fiberglass Insulation • 10" 16ga. Steel Joist • RC1 at 24" o.c. • 2 layers 5/8" Type C Gypsum Wallboard 	<p>61/79</p> <p style="text-align: right;">OL16-0207</p>
 <p style="text-align: center;">24" OC</p>	<ul style="list-style-type: none"> • 3/4" Sureboard 200S • 1 5/8" Self-piercing screws at 6'-0" o.c. • 6 1/4" R19 Fiberglass Insulation • 10" 16ga. Steel Joist • RC1 at 24" o.c. • 2 layers 5/8" Type C Gypsum Wallboard 	<p>60/38</p> <p style="text-align: right;">OL16-0208</p>
 <p style="text-align: center;">24" OC</p>	<ul style="list-style-type: none"> • 1" Maxxon Gyp-Crete on • 1/4" Maxxon Axoustic-Mat II • 3/4" Sureboard 200S • 1 5/8" Self-piercing screws at 6'-0" o.c. • 6 1/4" R19 Fiberglass Insulation • 10" 16ga. Steel Joist • RC1 at 24" o.c. • 2 layers 5/8" Type C Gypsum Wallboard 	<p>63/51</p> <p style="text-align: right;">OL16-0301</p>
 <p style="text-align: center;">24" OC</p>	<ul style="list-style-type: none"> • 3/4" Carpet • 1/2" Carpet Pad • 1" Maxxon Gyp-Crete on • 1/4" Maxxon Axoustic-Mat II • 3/4" Sureboard 200S • 1 5/8" Self-piercing screws at 6'-0" o.c. • 6 1/4" R19 Fiberglass Insulation • 10" 16ga. Steel joist • RC1 at 24" o.c. • 2 layers 5/8" Type C Gypsum Wallboard 	<p>64/83</p> <p style="text-align: right;">OL16-0302</p>

* Information used with permission from International Materials®, Inc. MarinoWARE® is a licensed partner.

Sure-Board® Wall

Sure-Board Wall is a shearwall sheathing used to resist lateral loads in a structure. Many shearwalls are not tested for sound, but Sure-Board has both shear values and sound ratings, providing a complete design solution.

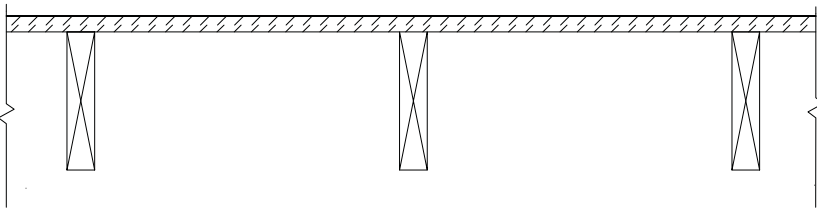
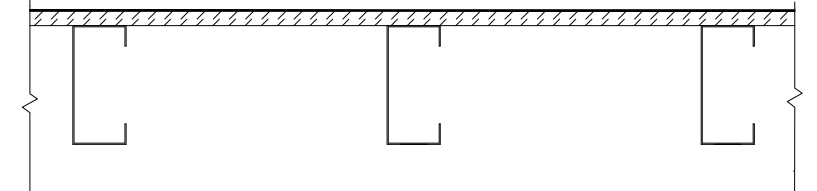
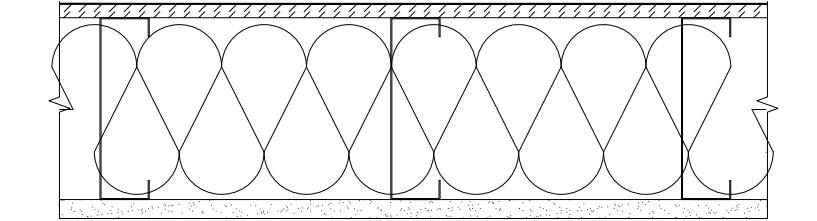
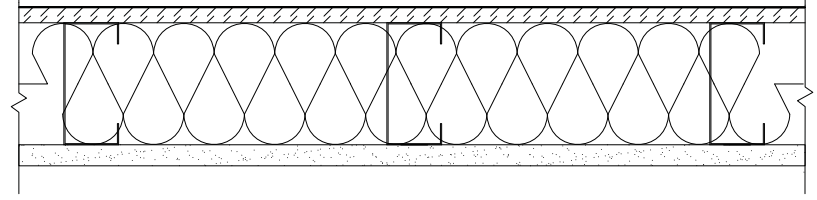
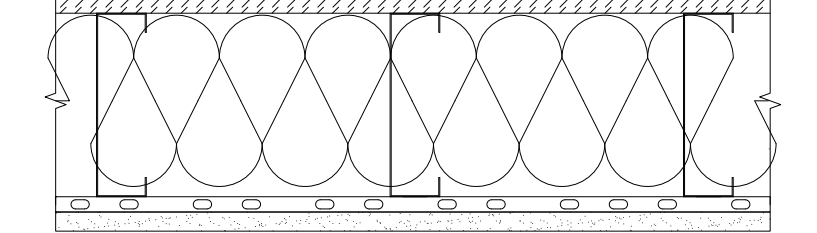
Assemblies	Descriptions	STC Rating
	<ul style="list-style-type: none"> • 2x4 wood studs @ 16" o.c. • Single 2x4 sill & double 2x4 head • 5/8" SureBoard Series 200 vertically one side only • 2 1/2" #8 drywall screws @ 8" o.c. On perimeter and 12" o.c. in the field 	<p style="text-align: center;">32</p> <p style="text-align: right;">TL05-387</p>
	<ul style="list-style-type: none"> • 1 layer SureBoard Series 200 vertically oriented one side only • 1 5/8" x 3 1/2" 20 gauge steel studs @ 24" o.c. 	<p style="text-align: center;">33</p> <p style="text-align: right;">TL05-391</p>
	<ul style="list-style-type: none"> • 1 layer SureBoard Series 200 one side • R19 fiberglass insulation • 6" metal studs 16 gauge by 1 1/4", 16" o.c. • 1 layer 5/8" Type X other side 	<p style="text-align: center;">47</p> <p style="text-align: right;">TL06-402</p>
	<ul style="list-style-type: none"> • 1 layer SureBoard Series 200 one side • 1 5/8" x 3 1/2" 20 gauge steel studs @ 24" o.c. • R19 fiberglass insulation • 1 layer 5/8" Type X other side 	<p style="text-align: center;">48</p> <p style="text-align: right;">TL05-392</p>
	<ul style="list-style-type: none"> • 1 layer SureBoard Series 200 one side • R19 fiberglass insulation • 6" metal studs 16 gauge by 1 1/4" @ 16" o.c. • RC1 Resilient channel other side • 5/8" Type X 	<p style="text-align: center;">54</p> <p style="text-align: right;">TL06-403</p>

* Information used with permission from International Materials®, Inc. MarinoWARE® is a licensed partner.

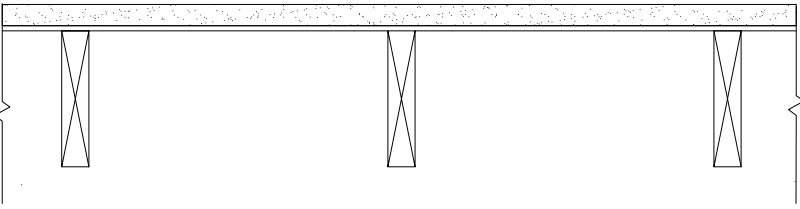
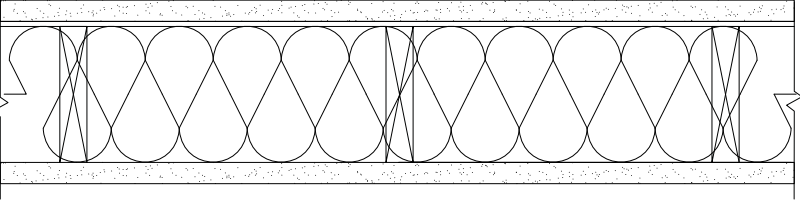
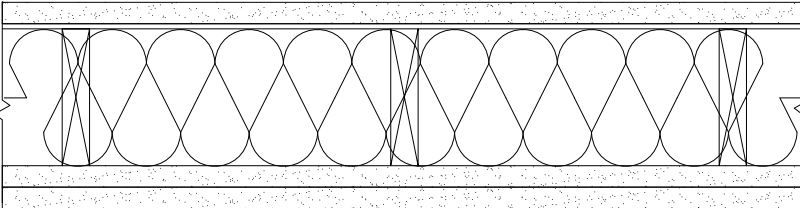
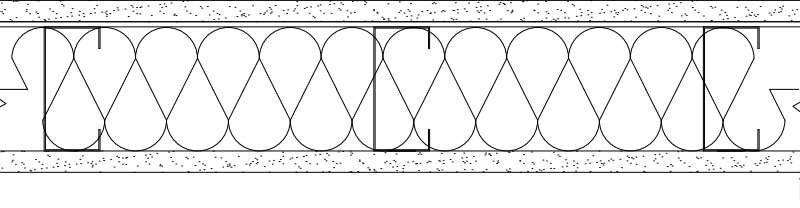
Assemblies	Descriptions	STC Rating
	<ul style="list-style-type: none"> • 1 layer SureBoard 200W • 1 layer 5/8" Type X same side • 2x4 wood studs 16" o.c. • Single 2x4 sill, double 2x4 head 	<p style="text-align: center;">34</p> <p style="text-align: right;">TL05-388</p>
	<ul style="list-style-type: none"> • 1 layer SureBoard 200W • 1 layer 5/8" Type X same side • 2x4 wood studs spaced horizontally @ 16" o.c. • Single 2x4 sill and double 2x4 head • R13 fiberglass insulation • 1 layer 5/8" Type X other side 	<p style="text-align: center;">41</p> <p style="text-align: right;">TL05-389</p>
	<ul style="list-style-type: none"> • 1 layer SureBoard 200W • 5/8" thick Type X drywall one side • 2x4 wood studs @ 16" o.c. • Single 2x4 sill & double 2x4 head • 2" #8 drywall screws @ 8" o.c. On perimeter and 12" o.c. in the field • R13 fiberglass insulation • 2 layers of 5/8" Type X other side 	<p style="text-align: center;">44</p> <p style="text-align: right;">TL05-390</p>
	<ul style="list-style-type: none"> • 1 layer SureBoard 200W • 1 layer 5/8 Type X same side • 1 5/8" x 3 1/2" 20 gauge steel studs @ 24" o.c. • R19 fiberglass insulation • 1 layer 5/8" Type X other side 	<p style="text-align: center;">49</p> <p style="text-align: right;">TL05-393</p>

* Information used with permission from International Materials®, Inc. MarinoWARE® is a licensed partner.

ViperStud®

The ViperStud is a high performance engineered drywall framing stud. Made from high-strength thinner steel, ViperStud provides a lighter, more efficient system. Using less steel helps reduce noise transmission.

3-5/8" VIPER25 @ 24" O.C.

STC Ratings

 <p>Wall Type A</p>	<ul style="list-style-type: none"> • Fiberglass Insulation • RC-Max resilient channel • 1 layer of 5/8" type X GWB, each side 	<p>52</p> <p>NOAL 18-0821</p>
 <p>Wall Type B</p>	<ul style="list-style-type: none"> • Fiberglass Insulation • 1 layer of 5/8" type x GWB, each side 	<p>46</p> <p>TL08-175</p>
 <p>Wall Type C</p>	<ul style="list-style-type: none"> • Fiberglass Insulation • RC-Max resilient channel • 2 layers of 5/8" type X GWB, each side 	<p>61</p> <p>NOAL 18-0823</p>
 <p>Wall Type F</p>	<ul style="list-style-type: none"> • 1 layer of 5/8" type X GWB, each side 	<p>41</p> <p>TL08-119</p>
 <p>Wall Type G</p>	<ul style="list-style-type: none"> • Fiberglass Insulation • RC-Max resilient channel • 1 layer 5/8" type X GWB, one side • 2 layers of 5/8" type X GWB, other side 	<p>57</p> <p>NOAL 18-0822</p>

3-5/8" VIPER25 @ 16" O.C.

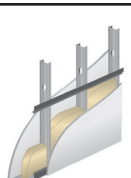
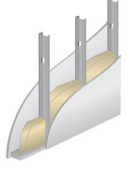
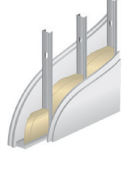
 <p>Wall Type A</p>	<ul style="list-style-type: none"> • Fiberglass Insulation • RC-Max resilient channel • 1 layer 5/8" type X GWB, each side 	<p>51</p> <p>96748.01A</p>
 <p>Wall Type B</p>	<ul style="list-style-type: none"> • Fiberglass Insulation • 1 layer 5/8" type X GWB, each side 	<p>47</p> <p>96748.01B</p>
 <p>Wall Type E</p>	<ul style="list-style-type: none"> • Fiberglass Insulation • 2 layers of 5/8" type X GWB, each side 	<p>55</p> <p>NOAL 18-0825</p>

3-5/8" VIPER20 @ 16" O.C.

STC Ratings

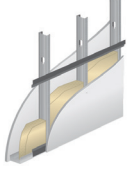
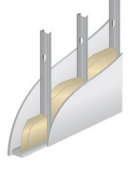
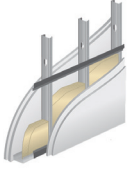
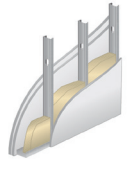
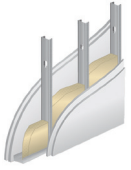
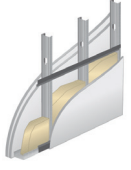

 <p>Wall Type A</p>	<ul style="list-style-type: none"> • Fiberglass Insulation • RC-Max resilient channel • 1 layer of 5/8" type X GWB, each side 	<p>51</p> <p>NOAL 18-0826</p>
 <p>Wall Type B</p>	<ul style="list-style-type: none"> • Fiberglass Insulation • 1 layer of 5/8" type x GWB, each side 	<p>44</p> <p>96749.01A</p>
 <p>Wall Type C</p>	<ul style="list-style-type: none"> • Fiberglass Insulation • RC-Max resilient channel • 2 layers of 5/8" type X GWB, each side 	<p>59</p> <p>NOAL 18-0828</p>
 <p>Wall Type D</p>	<ul style="list-style-type: none"> • Fiberglass Insulation • 1 layer of 5/8" type X GWB, one side • 2 layers of type X GWB, other side 	<p>49</p> <p>96749.01B</p>
 <p>Wall Type E</p>	<ul style="list-style-type: none"> • Fiberglass Insulation • 2 layers of 5/8" type X GWB, each side 	<p>50</p> <p>NOAL 18-0830</p>
 <p>Wall Type G</p>	<ul style="list-style-type: none"> • Fiberglass Insulation • RC-Max resilient channel • 1 layer 5/8" type X GWB, one side • 2 layers of 5/8" type X GWB, other side 	<p>55</p> <p>NOAL 18-0827</p>

RC-MAX®

RC-MAX is used as a furring over wood or steel framed walls and ceilings. The reduced contact RC-MAX affords with the supporting member offers economical means for controlling sound transmission. For walls, resilient furring channels should be installed with the mounting flange down, except at the starter row where the mounting flange may be installed with the flange up.

RC-MAX® with 3-5/8" ViperStud®

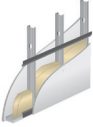
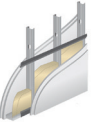
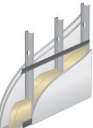
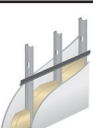
STC Rating

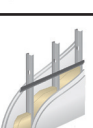
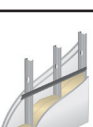
	Wall Type A	<ul style="list-style-type: none"> • Viper25 24" O.C. • Fiberglass insulation • RC-Max resilient channel • 1 Layer of 5/8" type X GWB, each side 	52	TR:18-0821
	Wall Type C	<ul style="list-style-type: none"> • Viper25 24" O.C. • Fiberglass insulation • RC-Max resilient channel • 2 layers of 5/8" type X GWB, each side 	61	TR:18-0823
	Wall Type G	<ul style="list-style-type: none"> • Viper25 24" O.C. • Fiberglass insulation • RC-Max resilient channel • 1 Layer 5/8" type X GWB, one side • 2 Layers of 5/8" type X GWB, other side 	57	TR:18-0822
	Wall Type A	<ul style="list-style-type: none"> • Viper25 16" O.C. • Fiberglass insulation • RC-Max resilient channel • 1 Layer 5/8" type X GWB, each side 	51	TR:96748.01A
	Wall Type A	<ul style="list-style-type: none"> • Viper20 16" O.C. • Fiberglass insulation • RC-Max resilient channel • 1 Layer 5/8" type X GWB, each side 	51	TR18-0826
	Wall Type C	<ul style="list-style-type: none"> • Viper20 16" O.C. • Fiberglass insulation • RC-Max resilient channel • 2 layers of 5/8" type X GWB, each side 	59	TR:18-0828
	Wall Type G	<ul style="list-style-type: none"> • Viper20 16" O.C. • Fiberglass insulation • RC-Max resilient channel • 1 Layer 5/8" type X GWB, one side • 2 Layers of 5/8" type X GWB, other side 	55	TR:18-0827

RC-MAX® with 3-5/8" StudRite®

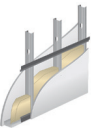
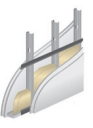
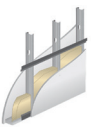
	Wall Type A	<ul style="list-style-type: none"> • StudRite (18 mil) 16" O.C. • Fiberglass insulation • RC-Max resilient channel • 1 Layer of 5/8" type X GWB, each side 	52	TR:2015115
	Wall Type C	<ul style="list-style-type: none"> • StudRite (18 mil) 24" O.C. • Fiberglass insulation • RC-Max resilient channel • 2 layers of 5/8" type X GWB, each side 	61	TR:2015114
	Wall Type A	<ul style="list-style-type: none"> • StudRite (18 mil) 24" O.C. • Fiberglass insulation • RC-Max resilient channel • 1 Layer 5/8" type X GWB, each side 	52	TR:2015113

18" Open Web Wood Truss

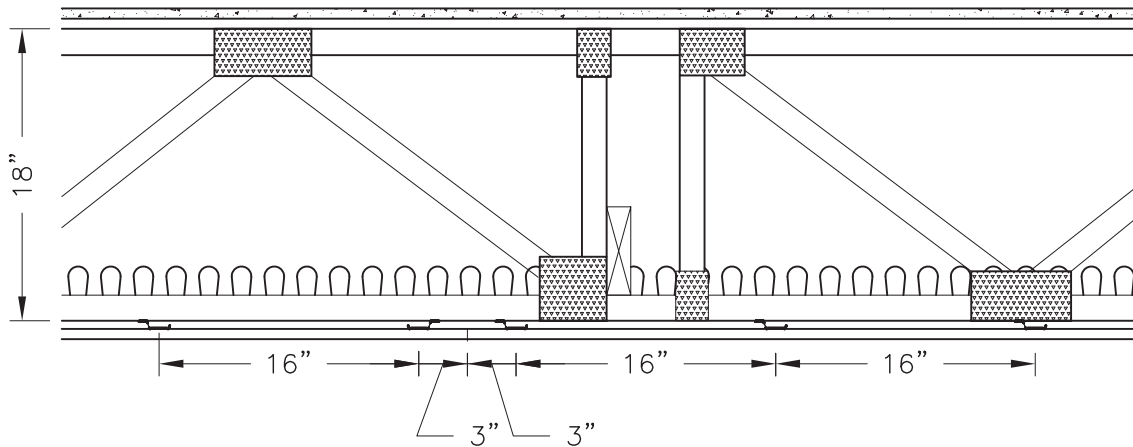

1 HR Assembly

- 3/4" gypsum concrete
- 1/8" sound attenuation mat
- 23/32" wood structural panel
- 18" OWT 24" o.c.
- Insulation (see chart)
- RC-MAX® spaced 16" o.c.
- 1 layer 5/8" type X

*check UL designs for specific assembly information

WITH FIBERGLASS	STC	IIC	TEST REPORTS
Bare Floor	57	48	L4816.05
Luxury Vinyl Tile	56	48	L4817.06
Engineered Wood	56	50	L4816.07

18" BLOWN-IN INSULATION	STC	IIC	TEST REPORTS
Bare Floor	59	50	L4816.09

11 7/8 Wood I-Joist

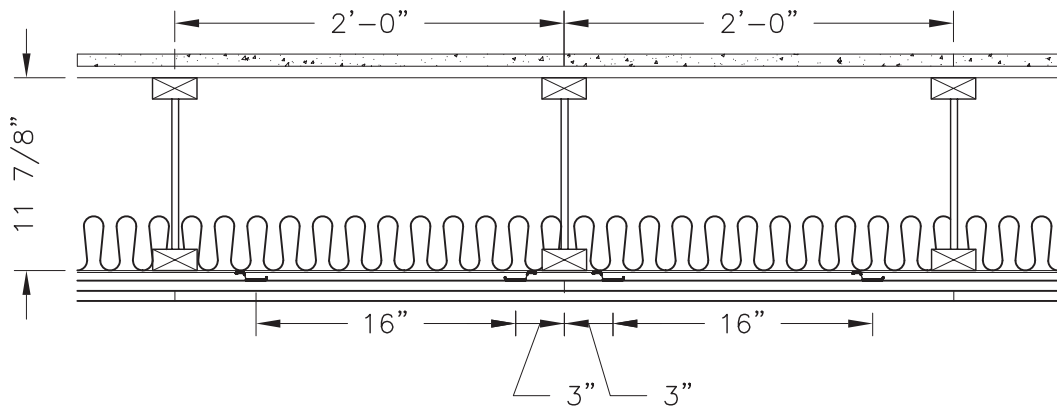

1 HR Assembly

- 3/4" gypsum concrete
- 1/8" sound attenuation mat
- 23/32" wood structural panel
- 11-7/8" wood i-joist 24" o.c.
- 3-1/2" fiberglass insulation
- RC-MAX® spaced 16" o.c.
- 2 layer 5/8" type X

*check UL designs for specific assembly information

WITH FIBERGLASS	STC	IIC	TEST REPORTS
Bare Floor	58	43	L4816.01
Luxury Vinyl Tile	58	51	L4816.02
Engineered Wood	58	55	L4816.03

Sound Rated Firestopping for Building Joints

MarinoWARE offers fire rated accessories that are effective at reducing sound transmission, in addition to their fire resistive properties. These accessories offer faster, easier installation and great acoustic benefits.

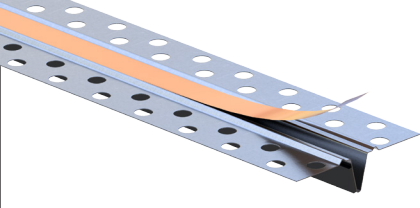
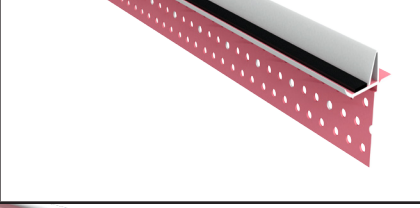
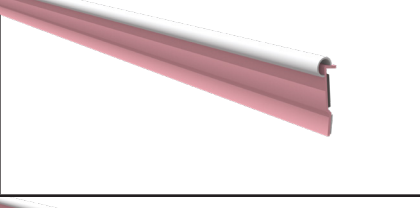
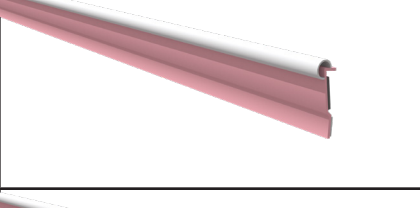
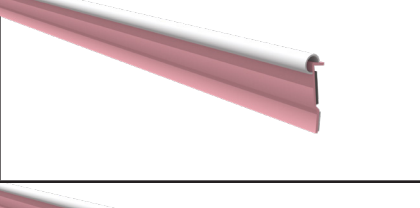
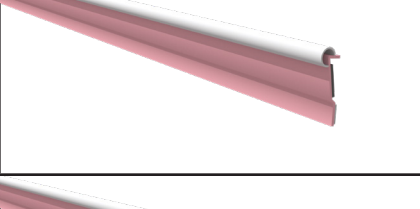
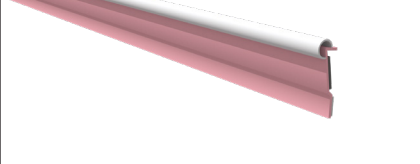
		STC Ratings		
	FAS093X	<ul style="list-style-type: none"> • 1 layer 5/8" Type X • 3-5/8" Viper (20EQ) Studs, 24" o.c. • Back to back studs @ center joint • FAS093X vertically at center joint • R13 fiberglass insulation • RC 1 resilient channel other side • 2 layers 5/8" Type X other side 	57	TL14-215
	Fire Bead	<ul style="list-style-type: none"> • Fire Bead at head-of-wall, both sides • 2 layers 5/8" Type X • 3-5/8" Viper (20EQ) Stud, 24" o.c. • R13 fiberglass insulation • 1 layer 5/8" Type X other side 	50	NOAL19-0116
	Fire Gasket	<ul style="list-style-type: none"> • Fire Gasket at head-of-wall, both sides • 2 layers 5/8" Type X • 3-5/8" Viper (20EQ) Studs, 24" o.c. • R13 Fiberglass insulation • 1 layer 5/8" Type X other side 	51	NOAL18-0762
	Fire Gasket	<ul style="list-style-type: none"> • Fire Gasket at head-of-wall, both sides • 2 layers 5/8" Type X • 3-5/8" Viper (20EQ) Studs, 24" o.c. • R13 Fiberglass insulation • 2 layers 5/8" Type X other side 	55	NOAL18-0763
	Fire Gasket	<ul style="list-style-type: none"> • Fire Gasket at head-of-wall, both sides • 1 layer 5/8" Type X • Double row 2-1/2" Viper (20EQ) studs (1" air space) 24" o.c. • Double layer R13 Fiberglass insulation • 1 layer 5/8" Type X other side 	58	NOAL18-0764
	Fire Gasket	<ul style="list-style-type: none"> • Fire Gasket at head-of-wall, both sides • 2 layers 5/8" Type X • Double row 2-1/2" Viper (20EQ) studs (1" air space) 24" o.c. • Double layer R13 Fiberglass insulation • 1 layer 5/8" Type X other side 	63	NOAL18-0765
	Fire Gasket	<ul style="list-style-type: none"> • Fire Gasket at head-of-wall, both sides • 2 layers 5/8" Type X • Double row 2-1/2" Viper (20EQ) studs (1" air space) 24" o.c. • Double layer R13 Fiberglass insulation • 2 layers 5/8" Type X other side 	67	NOAL18-0766

* Information used with permission from CEMCO®, LLC. MarinoWARE® is a licensed partner.

**Always check UL Design for specific assembly information.

STC Ratings

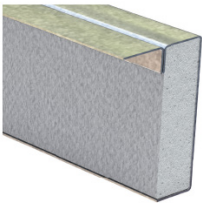
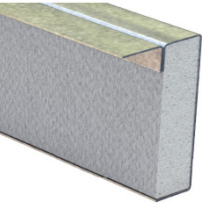
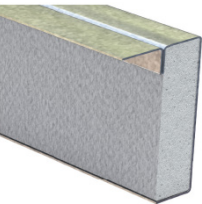
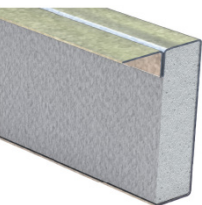
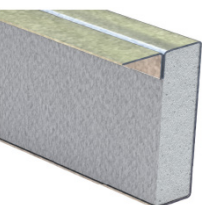
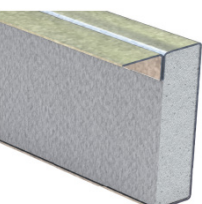
 <p style="text-align: right;">Fire Rip</p>	<p>Floor Assembly</p> <ul style="list-style-type: none"> • 2-1/2" lightweight concrete • 3" Composite metal deck • 6 pcf bare mineral fiber flute fill <p>Joint</p> <ul style="list-style-type: none"> • Marino\WARE FireRip4-both sides (2" joint) • 5/8" Type X both sides • Slotted track • 3-5/8" ViperStud 18mil 24" o.c. • 3-1/2 fiberglass batt 	<p style="text-align: center; font-size: 24pt; color: red;">46</p> <p style="text-align: right;">NOAL 25-12022</p>
 <p style="text-align: right;">Fire Rip</p>	<p>Floor Assembly</p> <ul style="list-style-type: none"> • 2-1/2" lightweight concrete • 3" Composite metal deck • Branded encapsulated flute fill <p>Joint</p> <ul style="list-style-type: none"> • MarinoWARE FireRip4 – on both sides (2" joint) • 5/8" Type X both sides • Slotted Track • 3-5/8" ViperStud 18mil @ 24" o.c. • 3-1/2" unfaced glass fiber batt insulation (R13) 	<p style="text-align: center; font-size: 24pt; color: red;">46</p> <p style="text-align: right;">NOAL 25-12023</p>
 <p style="text-align: right;">Fire Rip</p>	<p>Floor Assembly</p> <ul style="list-style-type: none"> • 2-1/2" lightweight concrete • 3" Composite metal deck • Branded encapsulated flute fill <p>Joint</p> <ul style="list-style-type: none"> • MarinoWARE FireRip4 – on both sides (2" joint) • (1) 5/8" Type X by (2) 5/8" Type X • Slotted Track • 3-5/8" ViperStud 18mil @ 24" o.c. • 3-1/2" unfaced glass fiber batt insulation (R13) 	<p style="text-align: center; font-size: 24pt; color: red;">51</p> <p style="text-align: right;">NOAL 25-12024</p>
 <p style="text-align: right;">Fire Rip</p>	<p>Floor Assembly</p> <ul style="list-style-type: none"> • 2-1/2" lightweight concrete • 3" Composite metal deck • 6 pcf bare mineral fiber flute fill <p>Joint</p> <ul style="list-style-type: none"> • MarinoWARE FireRip4 – on both sides (2" joint) • (1)5/8" Type X by (2) 5/8" Type X • Slotted Track • 3-5/8" ViperStud 18mil @ 24" o.c. • 3-1/2" unfaced glass fiber batt insulation (R13) 	<p style="text-align: center; font-size: 24pt; color: red;">51</p> <p style="text-align: right;">NOAL 25-12025R1</p>
 <p style="text-align: right;">Fire Rip</p>	<p>Floor Assembly</p> <ul style="list-style-type: none"> • 2-1/2" lightweight concrete • 3" Composite metal deck • 6 pcf bare mineral fiber flute fill <p>Joint</p> <ul style="list-style-type: none"> • MarinoWARE FireRip4 – on both sides (2" joint) • (2) 5/8" Type X by (2) 5/8" Type X • Slotted Track • 3-5/8" ViperStud 18mil @ 24" o.c. • 3-1/2" unfaced glass fiber batt insulation (R13) 	<p style="text-align: center; font-size: 24pt; color: red;">53</p> <p style="text-align: right;">NOAL 25-12026R1</p>
 <p style="text-align: right;">Fire Rip</p>	<p>Floor Assembly</p> <ul style="list-style-type: none"> • 2-1/2" lightweight concrete • 3" Composite metal deck • 6 pcf bare mineral fiber flute fill <p>Joint</p> <ul style="list-style-type: none"> • Marino\WARE FireRip2 – on both sides (1" joint) • (2)5/8" Type X by (2) 5/8" Type X • Slotted Track • 3-5/8" ViperStud 18mil @ 24" o.c. • 3-1/2" unfaced glass fiber batt insulation (R13) 	<p style="text-align: center; font-size: 24pt; color: red;">54</p> <p style="text-align: right;">NOAL 25-12027</p>

* Information used with permission from CEMCO®, LLC. MarinoWARE® is a licensed partner.

**Always check UL Design for specific assembly information.

STC Ratings

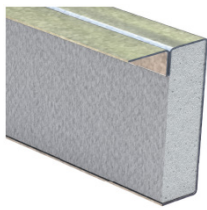
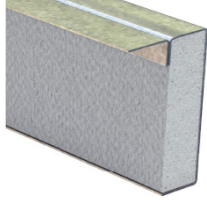
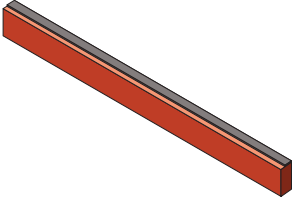
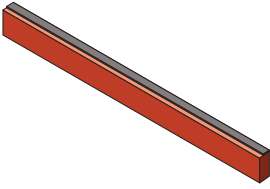
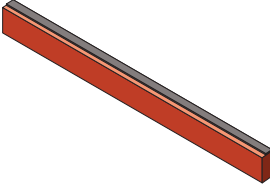
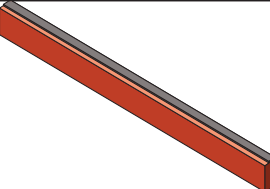
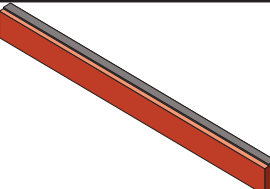
 <p>Fire Rip</p>	<p>Floor Assembly</p> <ul style="list-style-type: none"> • 2-1/2" lightweight concrete • 3" Composite metal deck • 4 pcf bare mineral fiber flute fill (33% compressed) <p>Joint</p> <ul style="list-style-type: none"> • MarinoWARE FireRip2 – on both sides (1" joint) • 5/8" Type X both sides • Slotted Track • 3-5/8" ViperStud 18mil @ 24" o.c. • 3-1/2" unfaced glass fiber batt insulation (R13) 	<p>47</p> <p>NOAL 25-12028</p>
 <p>Fire Rip</p>	<p>Floor Assembly</p> <ul style="list-style-type: none"> • 2-1/2" lightweight concrete • 3" Composite metal deck • 4 pcf bare mineral fiber flute fill (33% compressed) <p>Joint</p> <ul style="list-style-type: none"> • MarinoWARE FireRip4 (one side-2" joint) • 1" Shaft liner • 4" J Track (perimeter) • Bare mineral fiber (4" strip of compressed within top track) • 4" MarinoWARE CT studs @ 24" o.c. • 2-1/2" unfaced glass fiber batt insulation (R8) • (2) 5/8" Type x 	<p>50</p> <p>NOAL 25-12031R1</p>
 <p>HotRod Type X</p>	<ul style="list-style-type: none"> • HotRod Type X at head-of-wall one side only • 2 layers 5/8" Type X • 3-5/8" Viper (20EQ) studs, 24" o.c. • R13 Fiberglass insulation • 1 layer 5/8" Type X other side 	<p>51</p> <p>OL15-1012</p>
 <p>HotRod Type X</p>	<ul style="list-style-type: none"> • HotRod Type X, at head-of-wall one side • Backer rod at head-of-wall other side • 1 layer 5/8" Type X • 3-5/8" Viper (20EQ) studs, 24" o.c. • R13 Fiberglass insulation • 1 layer 5/8" Type X other side 	<p>54</p> <p>OL15-1017</p>
 <p>HotRod Type X</p>	<ul style="list-style-type: none"> • HotRod Type X at head-of-wall, both sides • 1 layer 5/8" Type X • Double row 2-1/2" Viper (20EQ) studs • (1" air space) 24" o.c. • Double layer R11 Fiberglass insulation • 1 layer 5/8" Type X other side 	<p>60</p> <p>TL17-430</p>
 <p>HotRod Type X</p>	<ul style="list-style-type: none"> • HotRod Type X at head-of-wall, both sides • 2 layers 5/8" Type X • 3-5/8" Viper (20EQ) Studs, 16" o.c. • R11 Fiberglass insulation • 2 layers 5/8" Type X other side 	<p>51</p> <p>TL17-418</p>
 <p>HotRod Type X</p>	<ul style="list-style-type: none"> • HotRod Type X at head-of-wall, both sides • 1 layer 5/8" Type X • Double row 2-1/2" Viper (20EQ) studs • (1" air space) 24" o.c. • Double layer R11 Fiberglass insulation • 2 layers 5/8" Type X other side 	<p>63</p> <p>TL17-433</p>

* Information used with permission from CEMCO®, LLC. MarinoWARE® is a licensed partner.

**Always check UL Design for specific assembly information.

STC Ratings

 <p>HotRod Type X</p>	<ul style="list-style-type: none"> • HotRod Type X at head-of-wall, both sides • 2 layers 5/8" Type X • Double row 2-1/2" Viper (20EQ) studs • (1" air space) 24" o.c. • Double layer R13 Fiberglass insulation • 2 layers 5/8" Type X other side 	<p>68</p> <p>TL14-285</p>
 <p>HotRod XL</p>	<ul style="list-style-type: none"> • HotRod XL at head-of-wall, both sides • 2 layers 5/8" Type X • 3-5/8" Viper (20EQ) Studs, 24" o.c. • R13 Fiberglass insulation • 1 layer 5/8" Type X other side 	<p>50</p> <p>NOAL19-0117</p>
 <p>HotRod XL</p>	<ul style="list-style-type: none"> • HotRod XL at head-of-wall, both sides • 1 layer 5/8" Type X • 3-5/8" Viper (20EQ) Studs, 24" o.c. • R13 Fiberglass insulation • RC1 resilient channel other side • 1 layer 5/8" Type X other side 	<p>52</p> <p>NOAL19-1039</p>
 <p>HotRod XL</p>	<ul style="list-style-type: none"> • HotRod XL at head-of-wall, both sides • 2 layers 5/8" Type X • 3-5/8" Viper (20EQ) Studs, 24" o.c. • R13 Fiberglass insulation • RC1 resilient channel other side • 1 layer 5/8" Type X other side 	<p>55</p> <p>NOAL19-1040</p>
 <p>HotRod XL</p>	<ul style="list-style-type: none"> • HotRod XL at head-of-wall, both sides • 2 layers 5/8" Type X • Double row 2-1/2" Viper (20EQ) studs • (1" air space) 24" o.c. • Double layer R13 Fiberglass insulation • 1 layer 5/8" Type X other side 	<p>63</p> <p>NOAL19-1048</p>
 <p>HotRod XL</p>	<ul style="list-style-type: none"> • HotRod XL at head-of-wall, both sides • 2 layers 5/8" Type X • Double row 2-1/2" Viper (20EQ) studs • (1" air space) 24" o.c. • Double layer R13 Fiberglass insulation • 2 layers 5/8" Type X other side 	<p>68</p> <p>NOAL19-1049</p>
 <p>Smoke & Sound Stop</p>	<ul style="list-style-type: none"> • Smoke & Sound Stop, both sides • 1 layer 5/8" Type X • Double row- 2-1/2" Viper (20EQ) studs • (1" air space) 24" o.c. • Double layer R13 Fiberglass insulation • 1 layer 5/8" Type X other side 	<p>60</p> <p>TL17-431</p>

* Information used with permission from CEMCO®, LLC. MarinoWARE® is a licensed partner.

**Always check UL Design for specific assembly information.

STC Ratings

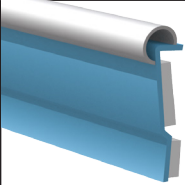
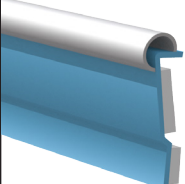
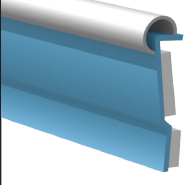
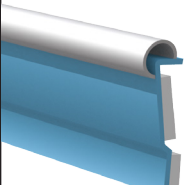
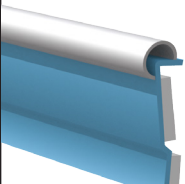
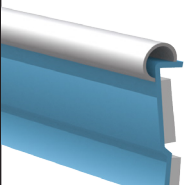
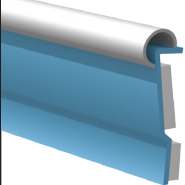
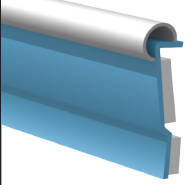
	Sound Gasket	<ul style="list-style-type: none"> • Sound Gasket around perimeter both sides • 2 layers 5/8" Type X • 3-5/8" Viper (20EQ) Studs, 24" o.c. • R13 Fiberglass insulation • 1 layer 5/8" Type X other side 	50	NOAL19-1043
	Sound Gasket	<ul style="list-style-type: none"> • Sound Gasket Head-of-wall, both sides • 2 layers 5/8" Type X • 3-5/8" Viper (20EQ) Studs, 24" o.c. • R13 Fiberglass insulation • Type X other side 1 layer 5/8" 	51	NOAL18-0762S
	Sound Gasket	<ul style="list-style-type: none"> • Sound Gasket at head-of-wall, both sides • 2 layers 5/8" Type X • 3-5/8" Viper (20EQ) Studs, 24" o.c. • R13 Fiberglass insulation • 2 layers 5/8" Type X other side 	55	NOAL18-0763S
	Sound Gasket	<ul style="list-style-type: none"> • Sound Gasket at head-of-wall, both sides • 1 layer 5/8" Type X • Double row 2-1/2" Viper (20EQ) studs (1" air space) 24" o.c. • Double layer R13 Fiberglass insulation • 1 layer 5/8" Type X other side 	58	NOAL18-0764S
	Sound Gasket	<ul style="list-style-type: none"> • Sound Gasket around perimeter, both sides • 2 layers 5/8" Type X • Double row 2-1/2" Viper (20EQ) studs (1" air space) 24" o.c. • Double layer R13 Fiberglass insulation • 1 layer 5/8" Type X other side 	62	NOAL19-1045
	Sound Gasket	<ul style="list-style-type: none"> • Sound Gasket at head-of-wall, both sides • 2 layers 5/8" Type X • Double row- 2-1/2" Viper (20EQ) studs (1" air space) 24" o.c. • Double layer R13 Fiberglass insulation • 1 layer 5/8" Type X other side 	63	NOAL18-0765S
	Sound Gasket	<ul style="list-style-type: none"> • Sound Gasket around perimeter, both sides • 2 layers 5/8" Type X • Double row 2-1/2" Viper (20EQ) studs (1" air space) 24" o.c. • Double layer R13 Fiberglass insulation • 2 layers 5/8" Type X other side 	66	NOAL19-1046
	Sound Gasket	<ul style="list-style-type: none"> • Sound Gasket at head-of-wall, both sides • 2 layers 5/8" Type X • Double row 2-1/2" Viper (20EQ) studs (1" air space) 24" o.c. • Double layer R13 Fiberglass insulation • 2 layers 5/8" Type X other side 	67	NOAL19-0766S

* Information used with permission from CEMCO®, LLC. MarinoWARE® is a licensed partner.
**Always check UL Design for specific assembly information.

STC Ratings

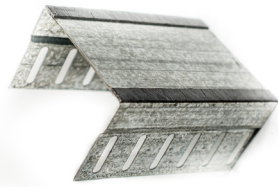
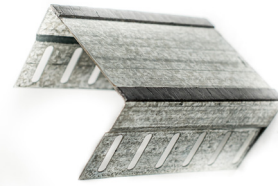
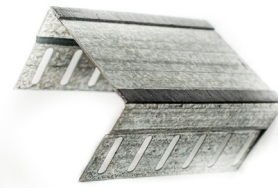
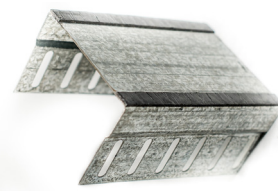
 <p>FAS Track 1000</p>	<ul style="list-style-type: none"> • FAS Track 1000 at head-of-wall • 2 layers 5/8" Type X • 3-5/8" Viper (20EQ) Studs, 24" o.c. • R13 Fiberglass Insulation • 1 layer 5/8" Type X other side 	<p style="text-align: center;">50</p> <p style="text-align: right;">OL15-1013</p>
 <p>FAS Track 1000</p>	<ul style="list-style-type: none"> • FAS Track 1000 at head-of-wall • 1 layer 5/8" Type X • RC1 resilient channel • 3-5/8" 20 GA Studs, 24" o.c. • R13 Fiberglass insulation • 1 layer 5/8" Type X other side 	<p style="text-align: center;">52</p> <p style="text-align: right;">TL08-696</p>
 <p>FAS Track 1000</p>	<ul style="list-style-type: none"> • FAS Track 1000 at head-of-wall • 1 layer 5/8" Type X • Double row 2-1/2" Viper (20EQ) studs (1" air space) 24" o.c. • Double layer R13 Fiberglass insulation • 1 layer 5/8" Type X other side 	<p style="text-align: center;">60</p> <p style="text-align: right;">TL12-475</p>
 <p>FAS Track 1000</p>	<ul style="list-style-type: none"> • FAS Track 1000 at head-of-wall • 1 layer 5/8" Type X • Double row 2-1/2" Viper (20EQ) studs (1" air space) 24" o.c. • Double layer R13 Fiberglass insulation • 2 layers 5/8" Type X other side 	<p style="text-align: center;">63</p> <p style="text-align: right;">TL12-476</p>

* Information used with permission from CEMCO®, LLC. MarinoWARE® is a licensed partner.

**Always check UL Design for specific assembly information.

GenieClip®

GenieClip is an engineered sound clip designed for superior acoustical performance in walls and ceilings. It is attached to 25 gauge furring channel, which is used to attach gypsum panel products.

Floor-Ceiling Assemblies

Test Report Number	Ceiling Type	Structure	Finish Floor	Underlayment	Subfloor	STC Rating (ASTM E90)	IIC Rating (ASTM E492)
G0535.09	GenieClip® RST, 5/8" GWB Type C	Open Web Truss	Vinyl Plank	GenieMat RST02PS	3/4" Gypsum, 3/4" OSB	63	59
G1707.07	GenieClip® RST, 5/8" GWB Type C	Open Web Truss	Porcelain Tile	GenieMat RST02PS	3/4" Gypsum, 3/4" OSB	62	54
G1707.08	GenieClip® RST, 5/8" GWB Type C	Open Web Truss	Wood	GenieMat FF06	3/4" Gypsum, 3/4" OSB	62	60
E5958.16	GenieClip® RST, 5/8" GWB Type C	Open Web Truss	Vinyl Plank	GenieMat RST05	3/4" OSB	60	55
E5958.17	GenieClip® RST, 5/8" GWB Type C	Open Web Truss	Vinyl Plank	None	3/4" OSB	60	51
F4832.12	GenieClip RST, 2x 1/2" GWB Type C	Engineered Joist	None	None	3/4" Gypsum, GenieMat FF25, 3/4" OSB	61	59
F4832.14	GenieClip RST, 2x 1/2" GWB Type C	Engineered Joist	Wood	GenieMat RST02	1/2" Plywood, 3/4" OSB	58	61
F4832.18	GenieClip RST, 2x 1/2" GWB Type C	Engineered Joist	Porcelain Tile	GenieMat RST02	1/2" Plywood, 3/4" OSB	59	55
F5500.03	GenieClip RST, 2x 1/2" GWB Type C	Engineered Joist	Vinyl Plank	GenieMat RST02	1/2" Plywood, 3/4" OSB	61	60
F5500.05	GenieClip RST, 2x 1/2" GWB Type C	Engineered Joist	Carpet	None	1/2" Plywood, 3/4" OSB	61	82
5013136 7013208	GenieClip RST, 1/2" GWB Type C	2x10 Solid Wood Joist	Ceramic Tile	GenieMat RST02	5/8" Plywood, 1/2" Plywood	58	52
5013143 7013216	GenieClip RST, 1/2" GWB Type C	2x10 Solid Wood Joist	Vinyl Plank	GenieMat RST02	5/8" Plywood, 1/2" Plywood	55	50
5013119 7013183	GenieClip RST Retrofit	2x10 Solid Wood Joist	Ceramic Tile	GenieMat RST02	5/8" Plywood, 1/2" Plywood	60	50
5014139 7014190	GenieClip RST, 1/2" GWB Type C	2x10 Solid Wood Joist	None	GenieMat RST02	3/4" Gypsum, GenieMat FF06, 5/8" Plywood	59	52

* GenieClip® data re-published with permission from Pliteq®

Floor-Ceiling Assemblies

Test Report Number	Ceiling Type	Structure	Finish Floor	Underlayment	Subfloor	STC Rating (ASTM E90)	IIC Rating (ASTM E492)
E5958.05	6" Drop Ceiling, GenieClip® LB, 5/8" GWB Type X	7" CLT	None	None	2x 11/16" AdvanTech Wood Subfloor, GenieMat® FF25	61	55
E5958.07	12" Drop Ceiling, GenieClip LB, 5/8" GWB Type X	7" CLT	Vinyl Plank	GenieMat RST05	None	58	58
F2761.08	GenieClip RST, 5/8" GWB Type C	7" CLT	Wood	GenieMat RST02	None	54	50
F2761.09	GenieClip RST, 5/8" GWB Type C	7" CLT	Porcelain Tile	GenieMat RST12	None	55	51
F3052.11	1/2" Gypsum, GenieClip RST, 5/8" GWB Type X	16" Insulated Concrete Form	None	None	None	64	55
F3052.12	1/2" Gypsum, GenieClip RST, 5/8" GWB Type X	16" Insulated Concrete Form	Wood	GenieMat RST05	1 1/4" Gypsum, 9/16" Steel Deck	63	65
F2761.04	GenieClip RST, 5/8" GWB Type C	10" Steel Joist	None	3/8" Sound Mat	3/4" Concrete Panel	59	52
F5689.18	GenieClip RST, 2x 5/8" GWB Type C	10" Steel Joist	Porcelain Tile	GenieMat RST12	None	62	50
F5689.20	GenieClip RST, 2x 5/8" GWB Type C	10" Steel Joist	Vinyl Plank	GenieMat RST02	None	60	52
F5689.05	GenieClip RST, 5/8" GWB Type C	4" Composite Deck	Vinyl Plank	GenieMat RST02	None	54	55
F5689.06	GenieClip RST, 5/8" GWB Type C	4" Composite Deck	Wood	GenieMat RST05	None	55	54
F0223.05	GenieClip RST, 5/8" GWB Type C	8" Hollow Core Plank	Vinyl Plank	GenieMat RST05	None	60	58
F0223.06	GenieClip RST, 5/8" GWB Type C	8" Hollow Core Plank	None	None	None	60	55
F0223.08	GenieClip RST, 5/8" GWB Type C	8" Hollow Core Plank	Porcelain Tile	GenieMat RST05	None	58	59
F1751.01	12" Drop Ceiling, 5/8" GWB Type C	6" Concrete Slab	None	None	None	63	42
F1751.02	12" Drop Ceiling, GenieClip C3, 5/8" GWB Type C	6" Concrete Slab	None	None	None	63	52
F1751.05	12" Drop Ceiling, GenieClip LB, 5/8" GWB Type C	6" Concrete Slab	None	None	None	64	53
F1751.03	12" Drop Ceiling, GenieClip C3, 5/8" GWB Type C	6" Concrete Slab	Wood	GenieMat RST05	None	62	68
F1751.04	12" Drop Ceiling, GenieClip LB, 5/8" GWB Type C	6" Concrete Slab	Wood	GenieMat RST05	None	63	69
F9365.07	6" Drop Ceiling, GenieClip LB, 5/8" GWB Type C	6" Concrete Slab	Vinyl Plank	GenieMat RST02PS	None	62	60

* GenieClip® data re-published with permission from Pliteq®

For more information, please contact MarinoWARE® Technical Services at 866.545.1545

This technical information reflects the most current information available and supersedes any and all previous publications effective Jun 3, 2026 | MW_SoundSolutionsGuide | © WARE Industries, Inc., 2026

Steel Stud Wall Assemblies

Test Report Number	Product	Steel Stud Wall Structure	GWB Layers (5/8" Type X)	TL @80 Hz (dB)	TL @100 Hz (dB)	STC Rating (ASTM E413)
TL07-620	GenieClip® RST	20 Ga., 3 5/8" wide spaced 24" O.C.	1x1	17	25	56
TL07-617	GenieClip RST	20 Ga., 3 5/8" wide spaced 24" O.C.	2x1	24	31	60
TL07-618	GenieClip RST	20 Ga., 3 5/8" wide spaced 24" O.C.	2x2	32	37	64
TL09-600	2x GenieClip RST	20 Ga., 3 5/8" wide spaced 24" O.C.	1x1	22	28	59
TL09-601	2x GenieClip RST	20 Ga., 3 5/8" wide spaced 24" O.C.	2x1	28	36	63
TL09-602	2x GenieClip RST	20 Ga., 3 5/8" wide spaced 24" O.C.	2x2	53	42	66

* GenieClip® data re-published with permission from Pliteq®

Wood Stud Assemblies

TL07-673	GenieClip RST	2x4 spaced 16" O.C.	1X1	20	27	57
TL07-672	GenieClip RST	2x4 spaced 16" O.C.	2x1	27	22	61
TL07-670	GenieClip RST	2x4 spaced 16" O.C.	2x2	31	39	64
TL07-644	GenieClip RST	2x4 spaced 16" O.C.	1x1 +1 layer	16	18	48
TL07-697	GenieClip RST	2x4 spaced 16" O.C.	2x1 +1 layer	17	24	54

* GenieClip® data re-published with permission from Pliteq®

Shaftwall

CT studs are non-load bearing and provide fire protection for shafts, stairwells, and areas where a one-sided application is necessary.

1 Hour Shaftwall Assembly

STC Rating

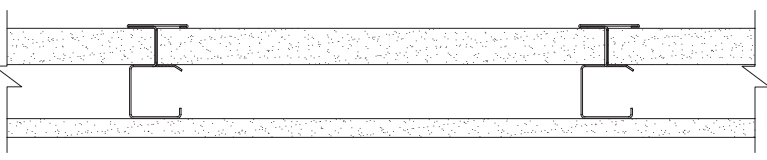
	<ul style="list-style-type: none"> Any UL Classified 1" thick Liner Board Type X MarinoWARE CT Stud and Tabbed Track Any UL Classified of one layer of 5/8" Type X or 1/2" Type C gypsum wallboard, oriented vertically 	2 1/2"	38/41*
		4"	41/47*
		6"	44/48*

2 Hour Shaftwall Assembly

STC Rating

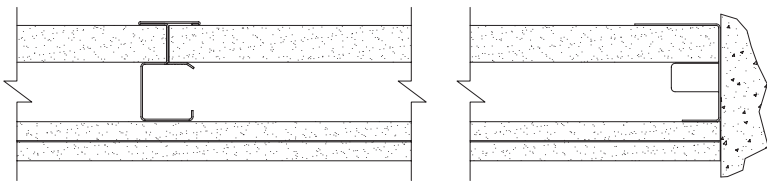
	<ul style="list-style-type: none"> Any UL Classified 1" thick Liner Board Type X MarinoWARE CT Stud and Tabbed Track Any UL Classified of two layers of 5/8" Type X or 1/2" Type C gypsum wallboard, oriented vertically 	2 1/2"	41/46*
		4"	44/49*
		6"	46/49*

2 Hour Stairwall Assembly

STC Rating

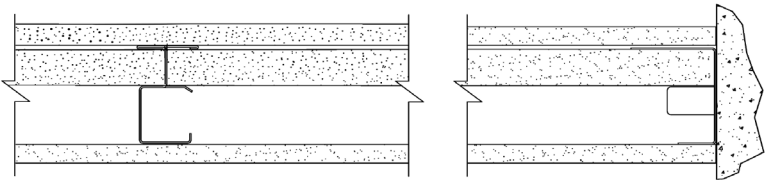
	<ul style="list-style-type: none"> Any UL Classified 1" thick Liner Board Type X MarinoWARE CT Stud and Tabbed Track Any UL Classified of two layers of 5/8" Type X or 1/2" Type C gypsum wallboard, oriented vertically. 	2 1/2"	40/45*
		4"	45/49*
		6"	45/50*

* Represents the same assembly with the addition of 1-1/2" of blanket insulation installed in the cavity.

JoistRite®

JoistRite is a steel framing stud that utilizes continuous lip reinforced triangular knockouts. The large knockouts help reduce noise transmission and make for an effective sound solution.

Summary for 1 Hour Fire & Sound Test

STC/IIC

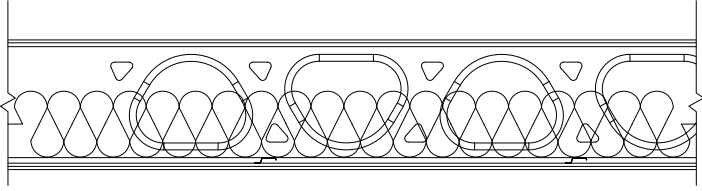
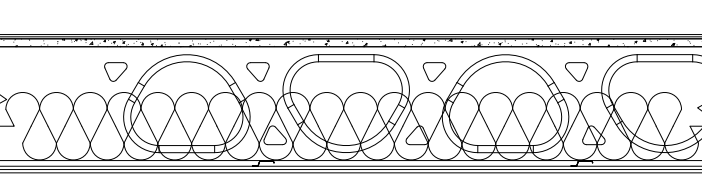
	<ul style="list-style-type: none"> • 3/4" thick T & G Plywood • 10" deep JoistRite steel joist @ 16" o.c. (16 GA) • 4", 4.5pcf mineral wool insulation (friction fitted between joists just under plywood) • RC-1 resilient channel spaced 16" o.c. below joists • Two layers of 1/2" thick Type C gypsum wallboard <p>For IIC 68 add:</p> <ul style="list-style-type: none"> • *44oz/ 7/16" thick carpet & • 3/8" foam rubber underlayment 	<p>52/45 68*</p> <p>5004025 / 7004075</p>
	<ul style="list-style-type: none"> • 1-1/2" thick Gypsum-concrete floor underlayment • 3/4" thick T & G Plywood • 10" deep JoistRite steel joist @ 16" o.c. (16 GA) • 4", mineral wool insulation (friction fitted between joists just under plywood) • RC-1 resilient channel spaced 16" o.c. below joists • Two layers of 1/2" thick Type C gypsum wallboard <p>For IIC 74 add:</p> <ul style="list-style-type: none"> • 44oz/ 7/16" thick carpet • 3/8" foam rubber underlayment 	<p>59/74</p> <p>5005013 / 7005028</p>

TECHNICAL SERVICES + SUPPORT | DesignGroup™

Our commitment to quality products extends to best-in-class design support. The Marino\WARE® DesignGroup™ offers a full range of technical support and engineering services, including professionally engineered stamped shop drawings, design and installation assistance on all Marino\WARE manufactured products, and expert advice on structural, nonstructural, fire and acoustic assemblies.

If you have questions or need more information on any of the products listed in this catalog, contact our Technical Services department at technicalservices@marinoware.com, or at 866.545.1545. In most cases Technical Services representatives can provide an immediate response.

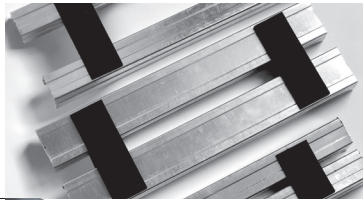

**Image above showcases StudRite® by Marino\WARE*

Specialists in Cold-Formed Steel Framing, Fire, + Sound Solutions



SOUND GUARD
THE SILENT STEEL FRAMING SYSTEM



- Narrower allowable wall thicknesses with better or equal STC ratings
- Does not require additional bracing or resilient channel



MARINO WARE®
Firestopping
Fire Board • Fire Gasket • HoRod XL

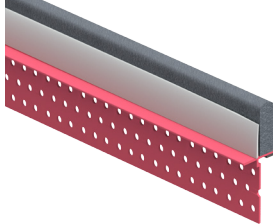

- Firestopping and sound control for building joints
- Innovative firestop devices for faster installation
- Prevents passage of fire, smoke and toxic fumes



StudRite®
JoistRite®

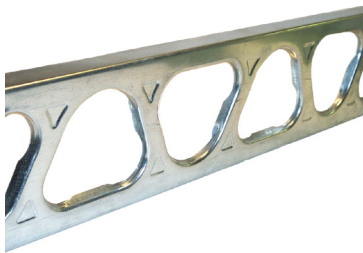

- High strength-to-mass ratio
- Easy to handle, increasing safety
- Increased structural performance due to lip reinforced triangular cutouts and embossments
- Efficient design for installing mechanical, electrical, plumbing, and other trades



SB



- Unsurpassed resistance against loads imposed by seismic activity, hurricane force winds, fire, mold, impact and blast, while actively reducing sound transmission



RC-MAX®

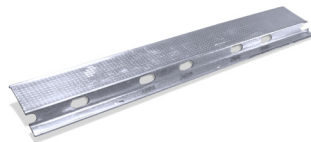

- RC-MAX is manufactured from 0.0190" 50 KSI steel for additional strength
- Offers economical means for controlling sound transmission



ClipSource

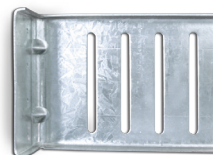

- A comprehensive line of connectors for cold formed steel framing
- Designed to facilitate quicker, more cost-effective installation, while making proper attachment of cold formed steel members easier



GenieClip®

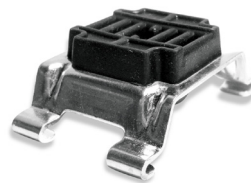

- Engineered for superior acoustical performance in reducing the transmission of airborne and impact sound through wall and floor/ceiling assemblies
- Easy and fast to install using standard steel furring channel



QuickFrame
Rough Opening System

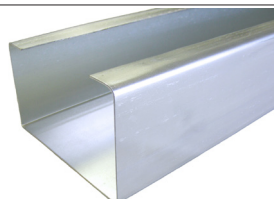

- Eliminates the need for multiple piece headers, jamps, and sills, reducing jobsite labor assembly time by up to 50%

YOUR SUCCESS DEPENDS ON QUALITY BUILDING PRODUCTS AND SO DOES OURS.

For over 30 years, Marino\WARE® , a division of Ware Industries, has provided customers with top quality cold-formed steel framing products.

We are committed to providing a superior customer experience through a vast selection of readily available products, a knowledgeable sales team, comprehensive technical support and services, prompt delivery through our fleet of trucks, and an extensive distribution network.

Our best-in-class product development team delivers innovative solutions to installation and cost challenges with products designed to save time, labor, and materials. In addition, we utilize the latest in roll forming techniques, maintain the latest level of technology available to the steel framing industry, and strictly adhere to all ASTM specifications.

Marino\WARE is 100% American-owned and operated. We take pride in creating local jobs, supporting local communities, and manufacturing products that reflect the uncompromising skill and ethics of our professional team. We operate state-of-the-art production facilities in New Jersey, Georgia, and Indiana, as well as a sales office in New York.

Visit MarinoWARE.com to experience our full line of innovative solutions.

For more information, please contact Marino\WARE® Technical Services at 866.545.1545

This technical information reflects the most current information available and supersedes any and all previous publications effective Jun 3, 2026 | MW_SoundSolutionsGuide | © WARE Industries, Inc., 2026

SOUND|GUARD

ISI StudRite®

SB

JoistRite®

ViperStuds

RC-MAX®

GenieClip™

Marino\WARE® operates state-of-the-art production facilities in New Jersey, Georgia, and Indiana, as well as a sales office in New York.

New Jersey Facility

400 Metuchen Road
South Plainfield, NJ 07080
800.627.4661
908.757.9000
Fax: 908.412.1442

Georgia Facility

777 Greenbelt Parkway
Griffin, GA 30223
800.504.8199
678.688.1312
Fax: 678.688.1379

Indiana Facility

4245 Railroad Avenue
East Chicago, IN 46312
866.636.6002
219.378.7100
Fax: 219.378.7106

New York Sales Office

51 John St. Ste. 1
Babylon, NY 11702
800.627.4667
631.691.2200
Fax: 631.691.1492

Marino\WARE® DesignGroup™

100 Hendrick Drive, Suite 200
McDonough, GA 30253
866.545.1545
678.688.7780
Fax: 770.507.2605