



NYC Department of Buildings
280 Broadway, New York, NY 10007
Patricia Lancaster, FAIA, Commissioner
(212) 566-5000, TTY: (212) 566-4769

Report of Materials and Equipment Acceptance Division

Pursuant to Administrative Code Section 27-131, the following equipment or material has been found acceptable for use subject to the terms and conditions contained herein.

MEA 226-07-M

Manufacturer:	MARINOWARE, 400 Metuchen Road, South Plainfield, NJ 07080
Trade Name(s):	JoistRite
Product:	2-hour fire-rated JoistRite floor/ceiling assembly for Class I construction
Pertinent Code Section(s)	27-323, 27-324, 27-280
Prescribed Test(s):	RS 5-1 (ASTM E119)
Laboratory:	Underwriters Laboratories, Inc.
Test Report(s):	UL File R25058 dated May 4, 2007 and UL Design G563

Description – Fire-rated floor/ceiling assembly consisting of 9¼” minimum depth 16-gauge JoistRite channel-shaped joists 24” o.c. with 9/16” deep, 22 gauge galvanized corrugated fluted steel deck and floor topping mixture, Maxxon Type D-C with a 3½” thick glass fiber insulation. Single layer of 5/8” thick, gypsum board attached to 25-gauge galvanized resilient channels (RC-1) secured perpendicular to the joist 12” o.c. with #10-16 x ¾” long self-drilling screw. The assembly shall be installed in accordance with manufacturer’s instructions and the Underwriter’s Laboratories Inc.’s listed on following pages in achieving the required fire-resistance rating.

Design No. G563

Unrestrained Assembly Ratings - 2 Hr

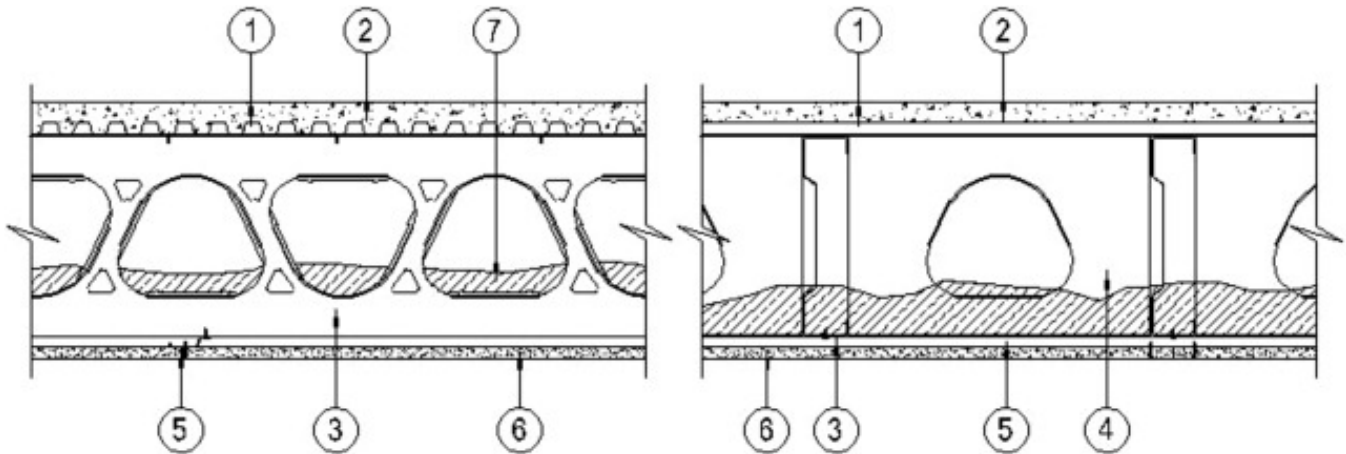

1. Steel Deck — Minimum 9/16 inch deep, 22 MSG galvanized corrugated fluted steel deck. Attached to each joist with #10 ¾ inch long screws at each side joint and no more than 10 inches o.c. between sides.

2. Floor Topping Mixture* — Compressive strength to the 3500 psi minimum. Minimum thickness to be 1 inch as measured from the top plane of the deck. Refer to manufacturer's instructions accompanying the material for specific mix design. An acrylic provided by the floor-topping manufacturer shall be applied to the steel deck prior to the installation of the floor topping mixture at a maximum application rate of 300 ft²/gallon.

MAXXON CORPORATION — Type D-C.

3. Structural Steel Members* — JoistRite channel-shaped joists, minimum 9¼ inches deep with minimum 2 inch wide flanges and ¾ inch long stiffening flanges. The web of each joist is provided with ¾ inch deep lip-reinforced trapezoidal cutouts as shown in the illustration. JoistRite rim track, minimum 9-3/8 inch deep with minimum 1½ inch top flange and minimum 2-5/16 inch bottom flange. The joists and rim tracks are fabricated from minimum 16 MSG galvanized steel. Joists spaced maximum 24 inches o.c. Floor joists attached to rim track using channel-shaped steel web stiffeners. At rim track splices bearing on supports, rim tracks are connected using an overlapping section of a 12 inch long splice plate, with four ¾ inch long self-drilling #10 screws to each rim piece.

MARINOWARE, Division of Ware Industries Inc. — Type JR JoistRite floor joists, Type JT JoistRite rim track.

4. Blocking and Bridging — Installed before construction loads are applied. The blocking consists of JoistRite solid blocking placed between each joist. Blocking attached to the top and bottom joist flanges with one #10 ¾ inch long self-drilling screw at each end tab of blocking. Blocking is fabricated from minimum 18 MSG galvanized steel, minimum 1-15/16 inch flanges, having the same depth as the joists. In addition, bridging consists of ½ inch by 1½ inch cold-rolled channel, minimum No. 16 gauge, attached to the bottom flanges of the joists and blocking. Cold-rolled channel attached to each blocking bottom flange with four #10 ¾ inch long self-drilling screws and to joist bottom flange with two screws.

5. Resilient Channels — ½ inch deep formed of minimum 26 MSG galvanized steel, spaced 12 inches o.c. perpendicular to joists. Channel splices overlapped 6 inches beneath steel joists. Channels secured to each joist with one #10 ¾ inch long self-drilling screw. Channels oriented opposite at wallboard butt joints (spaced 6 inches o.c.) as shown in the above illustration.

6. Gypsum Board — Nom 5/8 inch thick, 48 inch wide gypsum panels installed with long dimension perpendicular to resilient channels. Side joints centered between joists. Gypsum panels secured with 1 inch long Type S bugle-head screws spaced 8 inches o.c. in both the field and the perimeter, and 1 inch from side edges of the board.

NATIONAL GYPSUM CO — Types FSW-C

7. Batts and Blankets* — Glass fiber insulation, minimum 3½ inch thick, bearing the UL Classification Marking for Surface Burning Characteristics and/or Fire Resistance. Insulation fitted in the concealed space, draped over the resilient channel/gypsum panel ceiling membrane. See Batts and Blankets (BKNV or BZJZ) Categories for names of Classified companies.

8. Joint System — Not shown – Vinyl, dry or premixed joint compound, applied in two coats to joints and screw heads; paper tape, 2 inch wide, embedded in first layer of compound over all joints.

Terms and Conditions: The above-described two-hour fire-rated floor-ceiling assembly is accepted with the following conditions:

1. The design shall comply with the conditions of UL Design No. G563 test and with manufacturers instructions
2. Structural requirements shall comply with Subchapter 10, Reference Standard RS 10-3 and other applicable provisions of the New York City Building Code.
3. The acceptance of this assembly is limited to fire resistance only. Structural and other requirements shall be in accordance with pertinent Building Code, laboratories' listing and the manufacturer's requirements.
4. All shipments and deliveries of such materials shall be provided with a certificate or label certifying that the material shipped or delivered is equivalent to that tested and acceptable for use, as provided for in Section 27-131 of the New York City Building Code.

Final Acceptance July 17, 2007
Examined By Spin Derkudan