

# ICC-ES Evaluation Report

ESR-3578

Reissued October 2025

This report also contains:

- [City of NY Supplement](#)

Subject to renewal October 2026

- [FL Supplement w/ HVHZ](#)

ICC-ES Evaluation Reports are not to be construed as representing aesthetics or any other attributes not specifically addressed, nor are they to be construed as an endorsement of the subject of the report or a recommendation for its use. There is no warranty by ICC Evaluation Service, LLC, express or implied, as to any finding or other matter in this report, or as to any product covered by the report.

Copyright © 2025 ICC Evaluation Service, LLC. All rights reserved.

<p><b>DIVISION: 05 00 00 — METALS</b></p> <p><b>Section: 05 40 00 — Cold-Formed Metal Framing</b></p>	<p><b>REPORT HOLDER:</b></p> <p><b>WARE INDUSTRIES</b> d/b/a Marino\WARE</p>	<p><b>EVALUATION SUBJECT:</b></p> <p><b>CLIPSOURCE®</b> <b>CONNECTORS: UA,</b> <b>WSC, RCC, RCC w/HDW,</b> <b>BH, WRC</b></p>	
---	--	---	---

## 1.0 EVALUATION SCOPE

Compliance with the following codes:

- 2024, 2021, 2018 and 2015 [International Building Code® \(IBC\)](#)

Property evaluated:

- Structural

## 2.0 USES

The ClipSource® connectors are used to connect cold-formed steel framing members and to attach cold-formed steel framing members to concrete and steel framing members.

## 3.0 DESCRIPTION

### 3.1 General:

**3.1.1 Utility Angle (UA):** The UA is an L-shaped section and comes in lengths from 3<sup>1</sup>/<sub>4</sub> inches (83 mm) to 15<sup>3</sup>/<sub>4</sub> inches (400 mm). One leg of the UA is either 1<sup>1</sup>/<sub>2</sub> inches (38 mm) or 2 inches (51 mm) wide and the other leg is either 1<sup>1</sup>/<sub>2</sub> inches (38 mm), 2 inches (51 mm), 3 inches (76 mm), or 4 inches (102 mm) wide. When using a UA with unequal legs, the UA is attached to the supporting structure by the short leg and to the member being supported by the long leg. The UA series angles are formed from 54 mil-, 68 mil-, and 97-mil-thick steel conforming to ASTM A653 SS Grade 33 or ASTM A653 SS Grade 50 Class1. The UA angles have a G90 galvanized coating in accordance with ASTM A653. See [Table 1](#) for UA dimensions and allowable loads.

**3.1.2 Rigid Clip Connector (RCC) and Heavy Duty Washer (HDW):** The RCC is an L-shaped angle used to attach walls horizontally or vertically to masonry or concrete. The RCCs are formed from 97-mil-thick steel conforming to ASTM A653 SS Grade 50 Class 1 and have a G90 galvanized coating in accordance with ASTM A653. The RCCs are 1<sup>1</sup>/<sub>2</sub> inches (38 mm) by 4 inches (102 mm) and come in lengths of 3<sup>1</sup>/<sub>4</sub> inches (83 mm) [RCC358], 5<sup>1</sup>/<sub>4</sub> inches (133 mm) [RCC600], and 7<sup>3</sup>/<sub>4</sub> inches (197 mm) [RCC800]. The short leg has a <sup>9</sup>/<sub>16</sub>-inch-diameter (14 mm) center hole to accommodate a <sup>1</sup>/<sub>2</sub>-inch-diameter (13 mm) anchor bolt. See [Table 2](#) for allowable loads.

The HDW is a <sup>1</sup>/<sub>4</sub>-inch-thick-by-1<sup>5</sup>/<sub>16</sub>-inch-wide (6 mm by 33 mm) washer and may be used in conjunction with the RCC to increase the load-carrying capacity of the RCC. It is available in lengths of 3<sup>1</sup>/<sub>4</sub> inches (83 mm), 5<sup>1</sup>/<sub>4</sub> inches (133 mm), and 7<sup>3</sup>/<sub>4</sub> inches (197 mm). The HDW is made from ASTM A36 steel and painted gray for corrosion resistance. See [Table 2](#) for allowable loads.

**3.1.3 Slide Clip (WSC):** The WSC is an L-shaped angle used to attach exterior curtain wall studs to the primary structure and allows up to 1½ inches (38 mm) of vertical movement. The WSC is formed with 68-mil-thick steel conforming to ASTM A653 SS Grade 33 or ASTM A653 SS Grade 50 Class 1, has a G90 galvanized coating in accordance with ASTM A653, and is 4 inches (102 mm) wide. The short leg is 1½ inches (38 mm) long. The long leg varies in length from 3½ inches (89 mm) to 11½ inches (292 mm) and contains 3-inch-long-by-0.212-inch-wide (76 mm by 5 mm) vertical slots as follows:

MODEL NO.	VERTICAL SLOTS	LONG LEG (in)
WSC362	2	3.5
WSC600	4	5.5
WSC800	6	7.5
WSC1000	8	9.5
WSC1200	10	11.5

For SI: 1 inch = 25.4 mm.

See [Table 3](#) for allowable loads.

**3.1.4 Bridle Hanger (BH):** The BH is used to support cold-formed steel joists. The BH is available in heights ranging from 8 inches to 14 inches (203 mm to 356 mm) and can accommodate joist widths from 2 inches to 4 inches (51 mm to 102 mm). It is formed from ASTM A653 SS Grade 50 Class 1 steel with a thickness of 97 mils. See [Table 4](#) for allowable loads.

**3.1.5 Rigid Clip (WRC):** The WRC is an L-shaped angle used to attach wall studs to the primary structure. Use of the WRC in applications subject to loads other than vertical loads is outside the scope of this report. The WRC is formed with 68-mil-thick steel conforming to ASTM A653 SS Grade 50 Class 1 and has a G90 galvanized coating in accordance with ASTM A653. It is 4 inches (102 mm) wide with a short leg that is 1½ inches (38 mm) long and a long leg that varies in length from 3½ inches (89 mm) to 11½ inches (292 mm).

**3.1.6 Cold-Formed Steel Framing:** Cold-formed steel framing members that are to be attached to the connectors must be manufactured from materials in accordance with Section A3.1.1 of the American Iron and Steel Institute North American Specification for the Design of Cold-Formed Steel Structural Members (AISI S100). The following material properties are the required minimums for the cold-formed steel members:

STEEL THICKNESS DESIGNATION (mils)	DESIGN THICKNESS (in)	MINIMUM BASE-METAL THICKNESS (in)	YIELD STRESS (ksi)	TENSILE STRESS (ksi)
33	0.0346	0.0346	33	45
43	0.0451	0.0451	33	45
54	0.0566	0.0566	50	65
68	0.0713	0.0713	50	65
97	0.1017	0.1017	50	65
118	0.1242	0.1180	50	65

For SI: 1 inch = 25.4 mm, 1 ksi = 6.89 MPa.

**3.1.7 No. 14 Shouldered Screws:** The shouldered screws used with the WSC series clips are proprietary No. 14 screws and are supplied by Marino\WARE with each clip. Substitutions of the No. 14 shouldered screw are outside the scope of this report.

**3.1.8 Self-Drilling Screws:** Self-drilling tapping screws must be in compliance with ASTM C1513 or the subject of an ICC-ES evaluation report. The screws must have a minimum nominal diameter of 0.190 inch with 16 threads per inch, and a minimum head diameter of 0.29 inch (7 mm). Minimum nominal shear strength ( $P_{ss}$ ) must be 1600 pounds and minimum nominal tensile strength ( $P_{ts}$ ) must be 1935 pounds. The screws must be long enough to completely penetrate all the connected materials sufficiently to expose at least three complete threads.

**3.1.9 Weld Filler Metal:** Tabulated loads for connectors attached to supporting structural steel by welding are based on minimum E70XX electrodes.

## 4.0 DESIGN AND INSTALLATION

### 4.1 Design:

The connectors may be fastened to the supporting structure with screws, bolts, or welds. Design of the connection between the connector and the supporting structure must be submitted to the code official for approval and is outside the scope of this report.

When using the alternate basic load combinations in the 2024 and 2021 IBC Section 1605.2 (2018 and 2015 IBC Section 1605.3.2) that include wind or earthquake loads, the ASD allowable strength in [Tables 1](#) through [5](#) must not be increased by 33 $\frac{1}{3}$  percent, nor shall the alternative basic load combinations be reduced by a factor of 0.75.

#### 4.2 Installation:

The product must be installed in accordance with this report and the approved plans. If there is a conflict between this report and the plans submitted for approval, this report governs.

### 5.0 CONDITIONS OF USE:

The ClipSource<sup>®</sup> connectors described in this report comply with, or are suitable alternatives to what is specified in, those codes listed in Section 1.0 of this report, subject to the following conditions:

- 5.1 Drawings and engineering calculations verifying compliance with this report must be submitted to the code official for approval. The drawings and engineering calculations must be prepared by a registered design professional when required by the statutes of the jurisdiction in which the project is to be constructed.
- 5.2 The connection between the connector and the supporting structure must be designed by the designer of record for the applicable loads. Design of the connection between the connector and the supporting structure is outside the scope of this report.
- 5.3 The ClipSource<sup>®</sup> connectors described in this report are manufactured under a quality control program with inspections by ICC-ES.

### 6.0 EVIDENCE SUBMITTED

Data in accordance with the [ICC-ES Acceptance Criteria for Connectors Used with Cold-formed Steel Structural Members \(AC261\)](#), dated February 2019 (editorially revised April 2024).

### 7.0 IDENTIFICATION

- 7.1 The ICC-ES mark of conformity, electronic labeling, or the evaluation report number (ICC-ES ESR-3578) along with the name, registered trademark, or registered logo of the report holder [and/or listee] must be included in the product label. [Electronic labeling is the ICC-ES web address ([www.icc-es.org](http://www.icc-es.org)); specific URL related to the report; or the ICC-ES machine-readable code placed on the aforementioned items.]
- 7.2 In addition, the ClipSource<sup>®</sup> connectors described in this report must be stamped, labeled, or inked with the product designation and the company name (Marino\WARE). Each ClipSource<sup>®</sup> connector label must include the company name (Marino\WARE), company address, product designation/part name, quantity, and the ICC-ES evaluation report number (ESR-3578).
- 7.3 The report holder's contact information is the following:

**WARE INDUSTRIES d/b/a MarinoWARE**  
**400 METUCHEN ROAD**  
**SOUTH PLAINFIELD, NEW JERSEY 07080**  
**(908) 757-9000**  
[www.marinoware.com](http://www.marinoware.com)

TABLE 1—UTILITY ANGLES<sup>1</sup> (UA)

MODEL NO.	SIZE (in)	SCREWS <sup>2</sup>	ALLOWABLE LOAD (lb)											
			33 mil 33 ksi		43 mil 33 ksi		54 mil 33 ksi		54 mil 50 ksi		68 mil 50 ksi		97 mil 50 ksi	
			F1	F2	F1	F2	F1	F2	F1	F2	F1	F2	F1	F2
UA-113-16	1 1/2x1 1/2x3 1/4	3-#10	685	380	905	460	905	545	1315	545	1590	645	1590	645
UA-223-16	2x2x3 1/4	3-#10	685	380	905	460	905	545	1315	545	1590	645	1590	645
UA-133-16	1 1/2x3x3 1/4	3-#10	560	380	560	460	560	545	720	545	720	645	720	645
UA-143-16	1 1/2x4x3 1/4	3-#10	495	380	490	460	490	545	490	545	490	645	490	645
UA-115-16	1 1/2x1 1/2x5 1/4	3-#10	685	435	905	645	905	880	1315	880	1590	1040	1590	1040
UA-225-16	2x2x5 1/4	3-#10	685	435	905	645	905	880	1315	880	1590	1040	1590	1040
UA-135-16	1 1/2x3x5 1/4	3-#10	560	435	560	645	560	880	720	880	750	1040	750	1040
UA-145-16	1 1/2x4x5 1/4	3-#10	495	435	490	645	490	880	490	880	490	1040	490	1040
UA-118-16	1 1/2x1 1/2x7 3/4	5-#10	1145	725	1510	1075	1510	1300	2190	1300	2650	1535	2650	1535
UA-228-16	2x2x7 3/4	5-#10	1145	725	1510	1075	1510	1300	2190	1300	2650	1535	2650	1535
UA-138-16	1 1/2x3x7 3/4	5-#10	1145	725	1510	1075	1510	1300	2190	1300	2560	1535	2560	1535
UA-148-16	1 1/2x4x7 3/4	5-#10	1145	725	1470	1075	1470	1300	1470	1300	1470	1535	1470	1535
UA-119-16	1 1/2x1 1/2x9	5-#10	1145	725	1510	1075	1510	1510	2190	1510	2650	1780	2650	1780
UA-229-16	2x2x9	5-#10	1145	725	1510	1075	1510	1510	2190	1510	2650	1780	2650	1780
UA-139-16	1 1/2x3x9	5-#10	1145	725	1510	1075	1510	1510	2190	1510	2560	1780	2560	1780
UA-149-16	1 1/2x4x9	5-#10	1145	725	1510	1075	1510	1510	2190	1510	2375	1780	2375	1780
UA-1110-16	1 1/2x1 1/2x9 3/4	5-#10	1145	725	1510	1075	1510	1515	2190	1640	2650	1795	2650	1795
UA-2210-16	2x2x9 3/4	5-#10	1145	725	1510	1075	1510	1515	2190	1640	2650	1795	2650	1795
UA-1310-16	1 1/2x3x9 3/4	5-#10	1145	725	1510	1075	1510	1515	2190	1640	2560	1795	2560	1795
UA-1410-16	1 1/2x4x9 3/4	5-#10	1145	725	1510	1075	1510	1515	2190	1640	2375	1795	2375	1795
UA-1112-16	1 1/2x1 1/2x11 3/4	7-#10	1600	1015	2115	1505	2115	1975	3065	1975	3710	2325	3710	2325
UA-2212-16	2x2x11 3/4	7-#10	1600	1015	2115	1505	2115	1975	3065	1975	3710	2325	3710	2325
UA-1312-16	1 1/2x3x11 3/4	7-#10	1600	1015	2115	1505	2115	1975	3065	1975	3585	2325	3585	2325
UA-1412-16	1 1/2x4x11 3/4	7-#10	1600	1015	2115	1505	2115	1975	3065	1975	3330	2325	3330	2325
UA-1114-16	1 1/2x1 1/2x13 3/4	9-#10	2055	1305	2720	1935	2720	2310	3940	2310	4770	2725	4770	2725
UA-2214-16	2x2x13 3/4	9-#10	2055	1305	2720	1935	2720	2310	3940	2310	4770	2725	4770	2725
UA-1314-16	1 1/2x3x13 3/4	9-#10	2055	1305	2720	1935	2720	2310	3940	2310	4610	2725	4610	3230
UA-1414-16	1 1/2x4x13 3/4	9-#10	2055	1305	2720	1935	2720	2310	3940	2310	4280	2725	4280	3230
UA-1116-16	1 1/2x1 1/2x15 3/4	9-#10	2055	1305	2720	1935	2720	2645	3940	2645	4770	3120	4770	3120
UA-2216-16	2x2x15 3/4	9-#10	2055	1305	2720	1935	2720	2645	3940	2645	4770	3120	4770	3120
UA-1316-16	1 1/2x3x15 3/4	9-#10	2055	1305	2720	1935	2720	2645	3940	2645	4610	3120	4610	3120
UA-1416-16	1 1/2x4x15 3/4	9-#10	2055	1305	2720	1935	2720	2645	3940	2645	4280	3120	4280	3120
UA-113-14	1 1/2x1 1/2x3 1/4	3-#10	685	435	905	645	905	860	1315	860	1590	920	1590	920
UA-223-14	2x2x3 1/4	3-#10	685	435	905	645	905	860	1315	860	1590	920	1590	920
UA-133-14	1 1/2x3x3 1/4	3-#10	560	435	560	645	560	860	720	860	720	920	720	920
UA-143-14	1 1/2x4x3 1/4	3-#10	495	435	490	645	490	860	490	860	490	920	490	920
UA-115-14	1 1/2x1 1/2x5 1/4	3-#10	685	435	905	645	905	910	1315	1290	1590	1290	1590	1290
UA-225-14	2x2x5 1/4	3-#10	685	435	905	645	905	910	1315	1290	1590	1290	1590	1290
UA-135-14	1 1/2x3x5 1/4	3-#10	560	435	560	645	560	910	720	1290	720	1290	720	1290
UA-145-14	1 1/2x4x5 1/4	3-#10	495	435	490	645	490	910	490	1290	490	1290	490	1290
UA-118-14	1 1/2x1 1/2x7 3/4	5-#10	1145	725	1510	1075	1510	1515	2190	2055	2650	2150	2650	2150
UA-228-14	2x2x7 3/4	5-#10	1145	725	1510	1075	1510	1515	2190	2055	2650	2150	2650	2150
UA-138-14	1 1/2x3x7 3/4	5-#10	1145	725	1510	1075	1510	1515	2190	2055	2560	2150	2560	2150
UA-148-14	1 1/2x4x7 3/4	5-#10	1145	725	1510	1075	1470	1515	1470	2055	1470	2150	1470	2150
UA-119-14	1 1/2x1 1/2x9	5-#10	1145	725	1510	1075	1510	1515	2190	2150	2650	2150	2650	2150
UA-229-14	2x2x9	5-#10	1145	725	1510	1075	1510	1515	2190	2150	2650	2150	2650	2150
UA-139-14	1 1/2x3x9	5-#10	1145	725	1510	1075	1510	1515	2190	2150	2560	2150	2560	2150
UA-149-14	1 1/2x4x9	5-#10	1145	725	1510	1075	1510	1515	2190	2150	2375	2150	2375	2150
UA-1110-14	1 1/2x1 1/2x9 3/4	5-#10	1145	725	1510	1075	1510	1515	2190	2150	2650	2150	2650	2150
UA-2210-14	2x2x9 3/4	5-#10	1145	725	1510	1075	1510	1515	2190	2150	2650	2150	2650	2150
UA-1310-14	1 1/2x3x9 3/4	5-#10	1145	725	1510	1075	1510	1515	2190	2150	2560	2150	2560	2150
UA-1410-14	1 1/2x4x9 3/4	5-#10	1145	725	1510	1075	1510	1515	2190	2150	2375	2150	2375	2150
UA-1112-14	1 1/2x1 1/2x11 3/4	7-#10	1600	1015	2115	1505	2115	2120	3065	3010	3710	3010	3710	3010
UA-2212-14	2x2x11 3/4	7-#10	1600	1015	2115	1505	2115	2120	3065	3010	3710	3010	3710	3010
UA-1312-14	1 1/2x3x11 3/4	7-#10	1600	1015	2115	1505	2115	2120	3065	3010	3585	3010	3585	3010
UA-1412-14	1 1/2x4x11 3/4	7-#10	1600	1015	2115	1505	2115	2120	3065	3010	3330	3010	3330	3010
UA-1114-14	1 1/2x1 1/2x13 3/4	9-#10	2055	1305	2720	1935	2720	2725	3940	3645	4770	3870	4770	3870
UA-2214-14	2x2x13 3/4	9-#10	2055	1305	2720	1935	2720	2725	3940	3645	4770	3870	4770	3870
UA-1314-14	1 1/2x3x13 3/4	9-#10	2055	1305	2720	1935	2720	2725	3940	3645	4610	3870	4610	3870
UA-1414-14	1 1/2x4x13 3/4	9-#10	2055	1305	2720	1935	2720	2725	3940	3645	4280	3870	4280	3870
UA-1116-14	1 1/2x1 1/2x15 3/4	9-#10	2055	1305	2720	1935	2720	2725	3940	3870	4770	3870	4770	3870
UA-2216-14	2x2x15 3/4	9-#10	2055	1305	2720	1935	2720	2725	3940	3870	4770	3870	4770	3870
UA-1316-14	1 1/2x3x15 3/4	9-#10	2055	1305	2720	1935	2720	2725	3940	3870	4610	3870	4610	3870
UA-1416-14	1 1/2x4x15 3/4	9-#10	2055	1305	2720	1935	2720	2725	3940	3870	4280	3870	4280	3870

TABLE 1—UTILITY ANGLES<sup>1</sup> (UA) (Continued)

MODEL NO.	SIZE (in)	SCREWS <sup>2</sup>	ALLOWABLE LOAD (lb)											
			33 mil 33 ksi		43 mil 33 ksi		54 mil 33 ksi		54 mil 50 ksi		68 mil 50 ksi		97 mil 50 ksi	
			F1	F2	F1	F2	F1	F2	F1	F2	F1	F2	F1	F2
UA-113-12	1 1/2x1 1/2x3 3/4	3-#10	685	435	905	645	905	910	1315	1290	1590	1290	1590	1290
UA-223-12	2x2x3 3/4	3-#10	685	435	905	645	905	910	1315	1290	1590	1290	1590	1290
UA-133-12	1 1/2x3x3 3/4	3-#10	685	435	905	645	905	910	1315	1290	1535	1290	1535	1290
UA-143-12	1 1/2x4x3 3/4	3-#10	685	435	905	645	905	910	1315	1290	1425	1290	1425	1290
UA-115-12	1 1/2x1 1/2x5 1/4	3-#10	685	435	905	645	905	910	1315	1290	1590	1290	1590	1290
UA-225-12	2x2x5 1/4	3-#10	685	435	905	645	905	910	1315	1290	1590	1290	1590	1290
UA-135-12	1 1/2x3x5 1/4	3-#10	685	435	905	645	905	910	1315	1290	1535	1290	1535	1290
UA-145-12	1 1/2x4x5 1/4	3-#10	685	435	905	645	905	910	1315	1290	1425	1290	1425	1290
UA-118-12	1 1/2x1 1/2x7 3/4	5-#10	1145	725	1510	1075	1510	1515	2190	2150	2650	2150	2650	2150
UA-228-12	2x2x7 3/4	5-#10	1145	725	1510	1075	1510	1515	2190	2150	2650	2150	2650	2150
UA-138-12	1 1/2x3x7 3/4	5-#10	1145	725	1510	1075	1510	1515	2190	2150	2560	2150	2560	2150
UA-148-12	1 1/2x4x7 3/4	5-#10	1145	725	1510	1075	1510	1515	2190	2150	2375	2150	2375	2150
UA-119-12	1 1/2x1 1/2x9	5-#10	1145	725	1510	1075	1510	1515	2190	2150	2650	2150	2650	2150
UA-229-12	2x2x9	5-#10	1145	725	1510	1075	1510	1515	2190	2150	2650	2150	2650	2150
UA-139-12	1 1/2x3x9	5-#10	1145	725	1510	1075	1510	1515	2190	2150	2560	2150	2560	2150
UA-149-12	1 1/2x4x9	5-#10	1145	725	1510	1075	1510	1515	2190	2150	2375	2150	2375	2150
UA-1110-12	1 1/2x1 1/2x9 3/4	5-#10	1145	725	1510	1075	1510	1515	2190	2150	2650	2150	2650	2150
UA-2210-12	2x2x9 3/4	5-#10	1145	725	1510	1075	1510	1515	2190	2150	2650	2150	2650	2150
UA-1310-12	1 1/2x3x9 3/4	5-#10	1145	725	1510	1075	1510	1515	2190	2150	2560	2150	2560	2150
UA-1410-12	1 1/2x4x9 3/4	5-#10	1145	725	1510	1075	1510	1515	2190	2150	2375	2150	2375	2150
UA-1112-12	1 1/2x1 1/2x11 3/4	7-#10	1600	1015	2115	1505	2115	2120	3063	3010	3710	3010	3710	3010
UA-2212-12	2x2x11 3/4	7-#10	1600	1015	2115	1505	2115	2120	3063	3010	3710	3010	3710	3010
UA-1312-12	1 1/2x3x11 3/4	7-#10	1600	1015	2115	1505	2115	2120	3063	3010	3585	3010	3585	3010
UA-1412-12	1 1/2x4x11 3/4	7-#10	1600	1015	2115	1505	2115	2120	3063	3010	3330	3010	3330	3010
UA-1114-12	1 1/2x1 1/2x13 3/4	9-#10	2055	1305	2720	1935	2720	2725	3940	3870	4770	3870	4770	3870
UA-2214-12	2x2x13 3/4	9-#10	2055	1305	2720	1935	2720	2725	3940	3870	4770	3870	4770	3870
UA-1314-12	1 1/2x3x13 3/4	9-#10	2055	1305	2720	1935	2720	2725	3940	3870	4610	3870	4610	3870
UA-1414-12	1 1/2x4x13 3/4	9-#10	2055	1305	2720	1935	2720	2725	3940	3870	4280	3870	4280	3870
UA-1116-12	1 1/2x1 1/2x15 3/4	9-#10	2055	1305	2720	1935	2720	2725	3940	3870	4770	3870	4770	3870
UA-2216-12	2x2x15 3/4	9-#10	2055	1305	2720	1935	2720	2725	3940	3870	4770	3870	4770	3870
UA-1316-12	1 1/2x3x15 3/4	9-#10	2055	1305	2720	1935	2720	2725	3940	3870	4610	3870	4610	3870
UA-1416-12	1 1/2x4x15 3/4	9-#10	2055	1305	2720	1935	2720	2725	3940	3870	4280	3870	4280	3870

For SI: 1 inch = 25.4 mm, 1 ksi = 6.89 MPa, 1 lb = 4.45 N.

<sup>1</sup>F1 = Shear, F2 = Tension

<sup>2</sup>Fasteners must be a minimum of #10-16 self-drilling screws in accordance with Section 3.1.8.

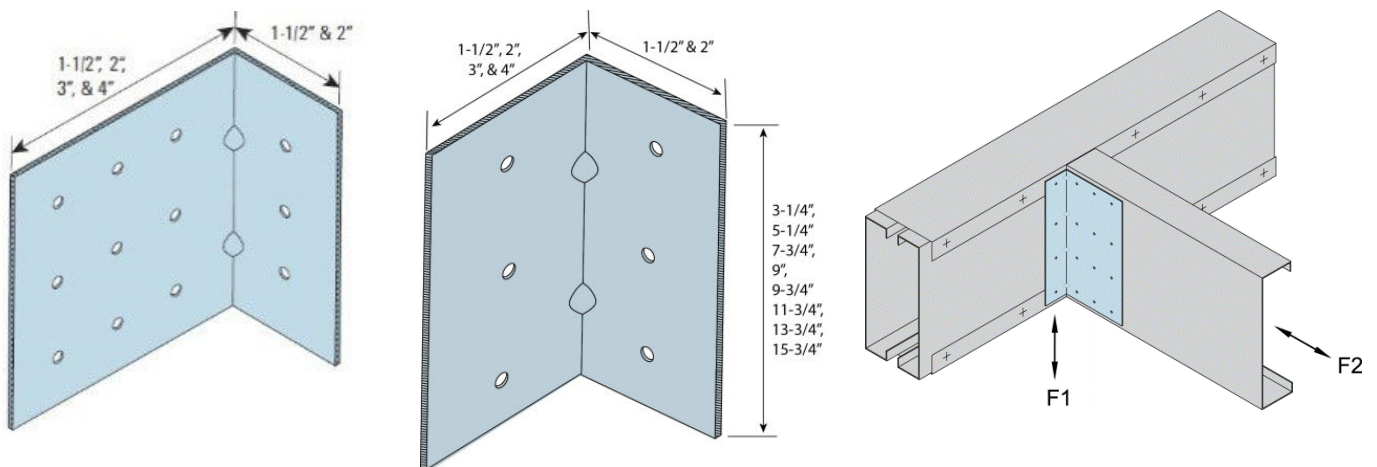

TABLE 2—RIGID CLIP CONNECTORS<sup>1,2</sup> (RCC)

CFS MEMBER		ALLOWABLE TENSION/COMPRESSION (lb) (F2)						ALLOWABLE SHEAR (lb) (F1)						ALLOWABLE MOMENT (in-k) (M1) FLEXIBILITY (Rad/in-lb x 10 <sup>6</sup> )					
Thickness (mils)	F <sub>y</sub> (ksi)	RCC358		RCC600		RCC800		RCC358		RCC600		RCC800		RCC358		RCC600		RCC800	
		No. of Screws		No. of Screws		No. of Screws		No. of Screws		No. of Screws		No. of Screws		No. of Screws		No. of Screws		No. of Screws	
		3	6	3	6	5	10	3	6	3	6	5	10	3	6	3	6	5	10
33	33	530	1060	530	1060	885	1765	450	450	600	710	850	850	0.82	1.51	1.79	2.29	2.78	3.00
		29.3	17.4	7.28	5.90	8.21	2.92												
43	33	790	1580	790	1580	1315	2115	450	450	600	710	850	850	0.82	1.51	1.79	2.29	2.78	3.00
		29.3	17.4	7.28	5.90	8.21	2.92												
54	50	1600	2115	1600	2115	2115	2115	840	1000	1250	1500	1860	1990	1.43	1.51	3.23	3.23	3.46	5.91
		29.3	17.4	7.28	5.90	8.21	2.92												
68	50	1640	2115	1640	2115	2115	2115	840	1000	1250	1500	1860	1990	1.43	2.32	3.22	3.22	3.46	5.71
		29.3	17.4	7.28	5.90	8.21	2.92												
97	50	1640	2115	1640	2115	2115	2115	840	1000	1250	1500	1860	1990	1.43	2.32	3.22	3.22	3.46	5.71
		29.3	17.4	7.28	5.90	8.21	2.92												
RIGID CLIP CONNECTORS (RCC) WITH WASHER (HDW)																			
33	33	530	1060	530	1060	885	1765	480	480	660	760	980	980	0.99	1.94	2.15	2.35	3.37	3.82
		28.4	8.07	4.06	4.06	6.39	1.7												
43	33	790	1580	790	1580	1315	2630	480	480	660	760	980	980	0.99	1.94	2.15	2.35	3.37	3.82
		28.4	8.07	4.06	4.06	6.39	1.7												
54	50	1600	3205	1600	2220	2670	3245	1070	1100	1450	1670	2160	2160	2.10	3.99	4.38	2.35	8.06	8.03
		28.4	8.07	4.06	4.06	6.39	1.7												
68	50	1640	3245	1640	3205	2735	3245	1070	1100	1450	1670	2160	2160	2.10	3.99	4.38	4.69	8.06	8.03
		28.4	8.07	4.06	4.06	6.39	1.7												
97	50	1640	3245	1640	3245	2735	3245	1070	1100	1450	1670	2160	2160	2.10	3.99	4.38	4.69	8.06	8.03
		28.4	8.07	4.06	4.06	6.39	1.7												

For **SI**: 1 pound = 4.45 N, 1 ksi = 6.89 MPa, 1 inch = 25.4 mm.

<sup>1</sup>Screws must be a minimum of #10-16 self-drilling screws in accordance with Section 3.1.8.

<sup>2</sup>Anchor bolt must be a ½-inch-diameter Grade 8 high strength bolt with a ½-inch Type A plain washer with a nominal outside diameter of 1 inch and nominal thickness of 0.1 inch.

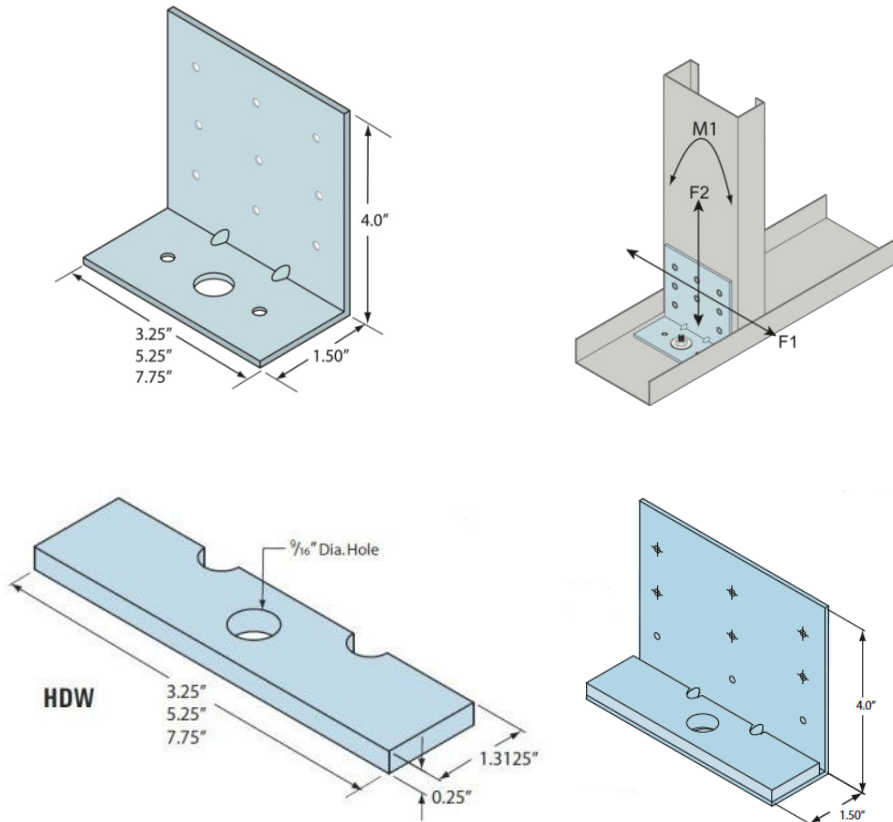

TABLE 3—SLIDE CLIPS (WSC)

QUANTITY OF SHOULDERED SCREWS	TENSION				COMPRESSION			
	CFS Member <sup>1</sup>				CFS Member <sup>1</sup>			
	33 mils (33 ksi)	43 mils (33 ksi)	54 mils (50 ksi)	68 mils (50 ksi)	33 mils (33 ksi)	43 mils (33 ksi)	54 mils (50 ksi)	68 mils (50 ksi)
<b>CONCENTRIC LOADING<sup>2</sup></b>								
2	375	560	650	650	375	560	650	650
3	565	840	980	980	565	840	965	965
4	750	1120	1305	1305	750	965	965	965
5	940	1400	1560	1560	940	965	965	965
<b>ECCENTRIC LOADING</b>								
2	375	560	650	650	375	560	650	650
3	565	840	980	980	565	790	790	790
4	750	1120	1305	1305	750	790	790	790
5	940	1400	1315	1315	790	790	790	790

For SI: 1 pound = 4.45 N, 1 ksi = 6.89 MPa.

<sup>1</sup>MarinoWARE's #14 shouldered screws, described in Section 3.1.7, must be used for attaching the WSC to the cold-formed steel curtain wall member.

<sup>2</sup>Conncentric loading based on fasteners placed at midpoint of slots.

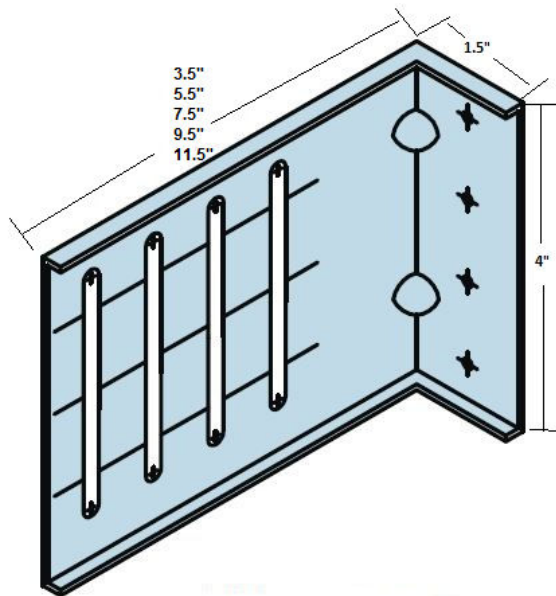
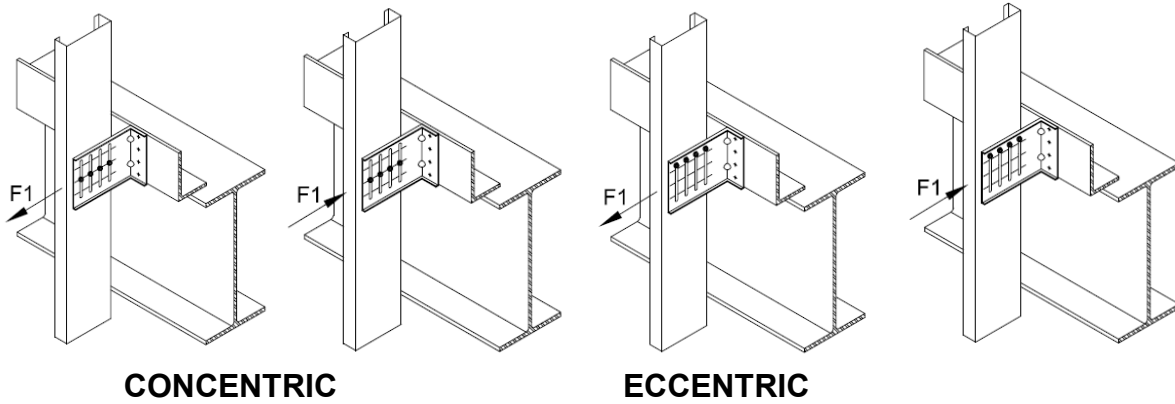

TABLE 4—BRIDLE HANGER<sup>1</sup> (BH)

MODEL NO.	DIMENSIONS (in)	CONNECTION TO HEADER <sup>1,2</sup>	ALLOWABLE LOAD (lb)
800BH12	2 <sup>1</sup> / <sub>8</sub> x 12 <sup>1</sup> / <sub>16</sub>	3 #10 Screws	2560
		1/8" x 2" fillet welds <sup>3</sup>	4015
		3 Hilti X-U Pins <sup>4</sup>	2665
925 BH12	2 <sup>1</sup> / <sub>8</sub> x 9 <sup>5</sup> / <sub>16</sub>	3 #10 Screws	2560
		1/8" x 2" fillet welds <sup>3</sup>	4015
		3 Hilti X-U Pins <sup>4</sup>	2665
100 BH12	2 <sup>1</sup> / <sub>8</sub> x 10 <sup>1</sup> / <sub>16</sub>	3 #10 Screws	2560
		1/8" x 2" fillet welds <sup>3</sup>	4015
		3 Hilti X-U Pins <sup>4</sup>	2665
1125 BH12	2 <sup>1</sup> / <sub>8</sub> x 11 <sup>5</sup> / <sub>16</sub>	3 #10 Screws	2560
		1/8" x 2" fillet welds <sup>3</sup>	4015
		3 Hilti X-U Pins <sup>4</sup>	2665
120 BH12	2 <sup>1</sup> / <sub>8</sub> x 12 <sup>1</sup> / <sub>16</sub>	3 #10 Screws	2560
		1/8" x 2" fillet welds <sup>3</sup>	4015
		3 Hilti X-U Pins <sup>4</sup>	2665
140 BH12	2 <sup>1</sup> / <sub>8</sub> x 14 <sup>1</sup> / <sub>16</sub>	3 #10 Screws	2560
		1/8" x 2" fillet welds <sup>3</sup>	4015
		3 Hilti X-U Pins <sup>4</sup>	2665
800DB12	4 <sup>9</sup> / <sub>32</sub> " x 12 <sup>1</sup> / <sub>16</sub>	3 #10 Screws	2560
		1/8" x 2" fillet welds <sup>3</sup>	4015
		3 Hilti X-U Pins <sup>4</sup>	2665
925DB12	4 <sup>9</sup> / <sub>32</sub> " x 9 <sup>5</sup> / <sub>16</sub>	3 #10 Screws	2560
		1/8" x 2" fillet welds <sup>3</sup>	4015
		3 Hilti X-U Pins <sup>4</sup>	2665
100DB12	4 <sup>9</sup> / <sub>32</sub> " x 10 <sup>1</sup> / <sub>16</sub>	3 #10 Screws	2560
		1/8" x 2" fillet welds <sup>3</sup>	4015
		3 Hilti X-U Pins <sup>4</sup>	2665
1125DB12	4 <sup>9</sup> / <sub>32</sub> " x 11 <sup>5</sup> / <sub>16</sub>	3 #10 Screws	2560
		1/8" x 2" fillet welds <sup>3</sup>	4015
		3 Hilti X-U Pins <sup>4</sup>	2665
120DB12	4 <sup>9</sup> / <sub>32</sub> " x 12 <sup>1</sup> / <sub>16</sub>	3 #10 Screws	2560
		1/8" x 2" fillet welds <sup>3</sup>	4015
		3 Hilti X-U Pins <sup>4</sup>	2665
140DB12	4 <sup>9</sup> / <sub>32</sub> " x 14 <sup>1</sup> / <sub>16</sub>	3 #10 Screws	2560
		1/8" x 2" fillet welds <sup>3</sup>	4015
		3 Hilti X-U Pins <sup>4</sup>	2665

For SI: 1 inch = 25.4 mm, 1 pound = 4.4482 N.

<sup>1</sup>Fastening specified is for each tab of the BH.

<sup>2</sup>The screw connection is based on the BH being attached to a 68 mil cold-formed steel framing member with a minimum steel tensile strength (F<sub>u</sub>) of 74 ksi. The Hilti pin connection is based on the BH being attached to a 3/8-inch-thick hot rolled steel framing member with minimum yield strength (F<sub>y</sub>) of 36 ksi and minimum tensile strength (F<sub>u</sub>) of 58 ksi.

<sup>3</sup>Welding electrodes must be a minimum of E70XX electrodes.

<sup>4</sup>Hilti X-U pins are recognized in [ESR-2269](#) and must be installed accordingly.

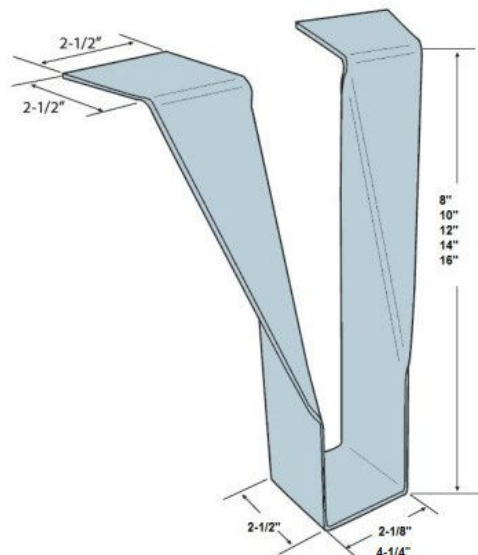

TABLE 5—RIGID CLIPS (WRC) ALLOWABLE LOADS<sup>1</sup> (lb)

MODEL NO.	CFS MEMBER					
	33 mils (33 ksi)	43 mils (33 ksi)	54 mils (33 ksi)	54 mils (50 ksi)	68 mils (50 ksi)	97 mils (50 ksi)
WRC600	620	620	620	1170	1170	1170
WRC1200	310	310	310	465	465	465

For SI: 1 pound = 4.45 N, 1 ksi = 6.89 MPa.

<sup>1</sup>The use of the WRC in applications subject to loads other than vertical loads is outside the scope of this report.

<sup>2</sup>Screws must be a minimum of #10-16 self-drilling screws in accordance with Section 3.1.8.

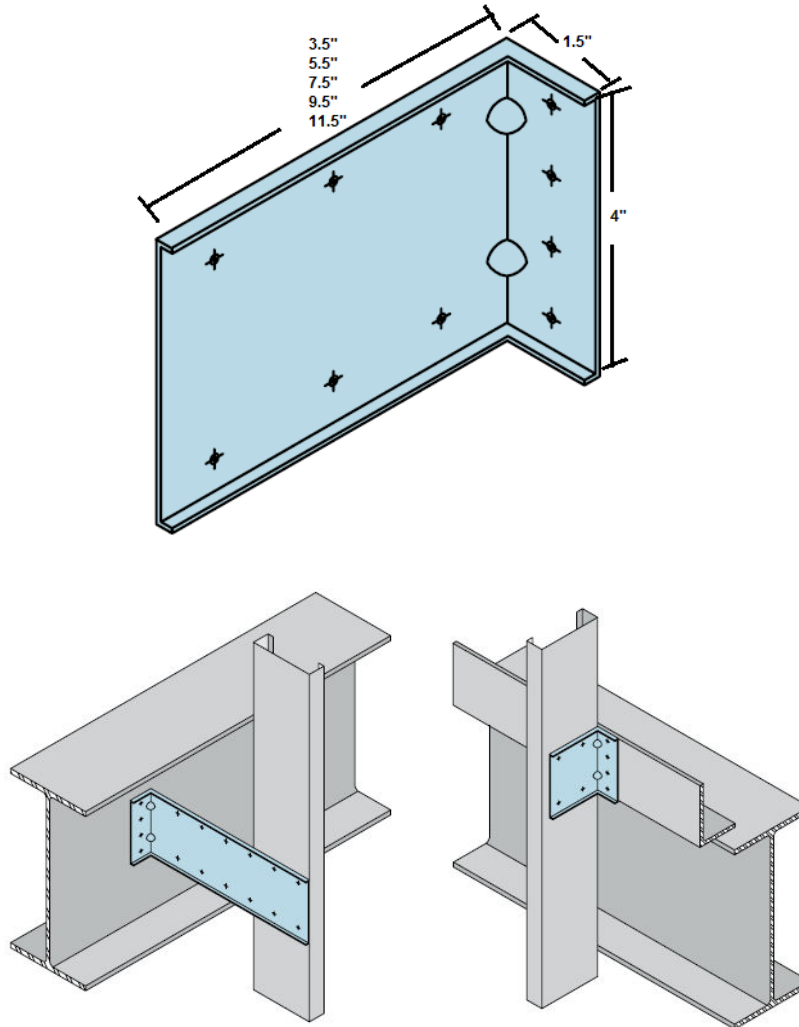

DIVISION: 05 00 00—METALS  
Section: 05 40 00—Cold-Formed Metal Framing

**REPORT HOLDER:**

WARE INDUSTRIES d/b/a Marino\WARE

**EVALUATION SUBJECT**

CLIPSOURCE® CONNECTORS: UA, WSC, RCC, RCC w/HDW, BH, WRC

**1.0 REPORT PURPOSE AND SCOPE****Purpose:**

The purpose of this evaluation report supplement is to indicate that the ClipSource® Connectors: UA, WSC, RCC, RCC w/HDW, BH and WRC, described in ICC-ES evaluation report [ESR-3578](#), have also been evaluated for compliance with the codes noted below as adopted by the New York City Department of Building.

**Applicable code editions:**

- 2022 *New York City Building Code*

**2.0 CONCLUSIONS**

The ClipSource® Connectors: UA, WSC, RCC, RCC w/HDW, BH and WRC, described in Sections 2.0 through 7.0 of ICC-ES evaluation report [ESR-3578](#), comply with the *New York City Building Code* Chapter 22, and are subject to conditions of use described in this supplement.

**3.0 CONDITIONS OF USE**

The ClipSource® Connectors: UA, WSC, RCC, RCC w/HDW, BH and WRC, described in the evaluation report must comply with all the following conditions:

- All applicable sections in the evaluation report [ESR-3578](#).
- The design, installation, conditions of use and identification of the ClipSource® Connectors: UA, WSC, RCC, RCC w/HDW, BH and WRC are in accordance with the 2015 *International Building Code*® (2015 IBC) provisions noted in the evaluation report [ESR-3578](#).
- The design, installation, and inspection are in accordance with additional requirements of the 2022 *New York City Building Code* Chapters 16, 17 and 22, as applicable.

This supplement expires concurrently with the evaluation report, reissued October 2025.

DIVISION: 05 00 00—METALS

Section: 05 40 00—Cold-Formed Metal Framing

## REPORT HOLDER:

WARE INDUSTRIES d/b/a MarinoWARE

## EVALUATION SUBJECT:

CLIPSOURCE® CONNECTORS: UA, WSC, RCC, RCC w/HDW, BH, WRC

## 1.0 REPORT PURPOSE AND SCOPE

## Purpose:

The purpose of this evaluation report supplement is to indicate that ClipSource® Connectors: UA, WSC, RCC, RCC w/HDW, BH, WRC, described in ICC-ES evaluation report [ESR-3578](#), have also been evaluated for compliance with the codes noted below.

## Applicable code editions:

- 2023 Florida Building Code—Building

## 2.0 CONCLUSIONS

The ClipSource® Connectors: UA, WSC, RCC, RCC w/HDW, BH, WRC, described in Sections 2.0 through 7.0 of ICC-ES evaluation report [ESR-3578](#), comply with the *Florida Building Code—Building*. The design requirements must be determined in accordance with the *Florida Building Code—Building*. The installation requirements noted in ICC-ES evaluation report [ESR-3578](#) for the 2021 *International Building Code*® meet the requirements of the *Florida Building Code—Building*.

Use of the ClipSource® Connectors: UA, WSC, RCC, RCC w/HDW, BH, WRC has also been found to be in compliance with the High-Velocity Hurricane Zone provisions of the *Florida Building Code—Building* with the following condition:

- For connections subject to uplift, the connection must be designed for no less than 700 pounds (3114 N).

For products falling under Florida Rule 61G20-3, verification that the report holder's quality assurance program is audited by a quality assurance entity approved by the Florida Building Commission for the type of inspections being conducted is the responsibility of an approved validation entity (or the code official, when the report holder does not possess an approval by the Commission). Florida Rule 61G20-3 is applicable to products and/or systems which comprise the building envelope and structural frame for compliance with the structural requirements of the Florida Building Code.

This supplement expires concurrently with the evaluation report, reissued October 2025.