

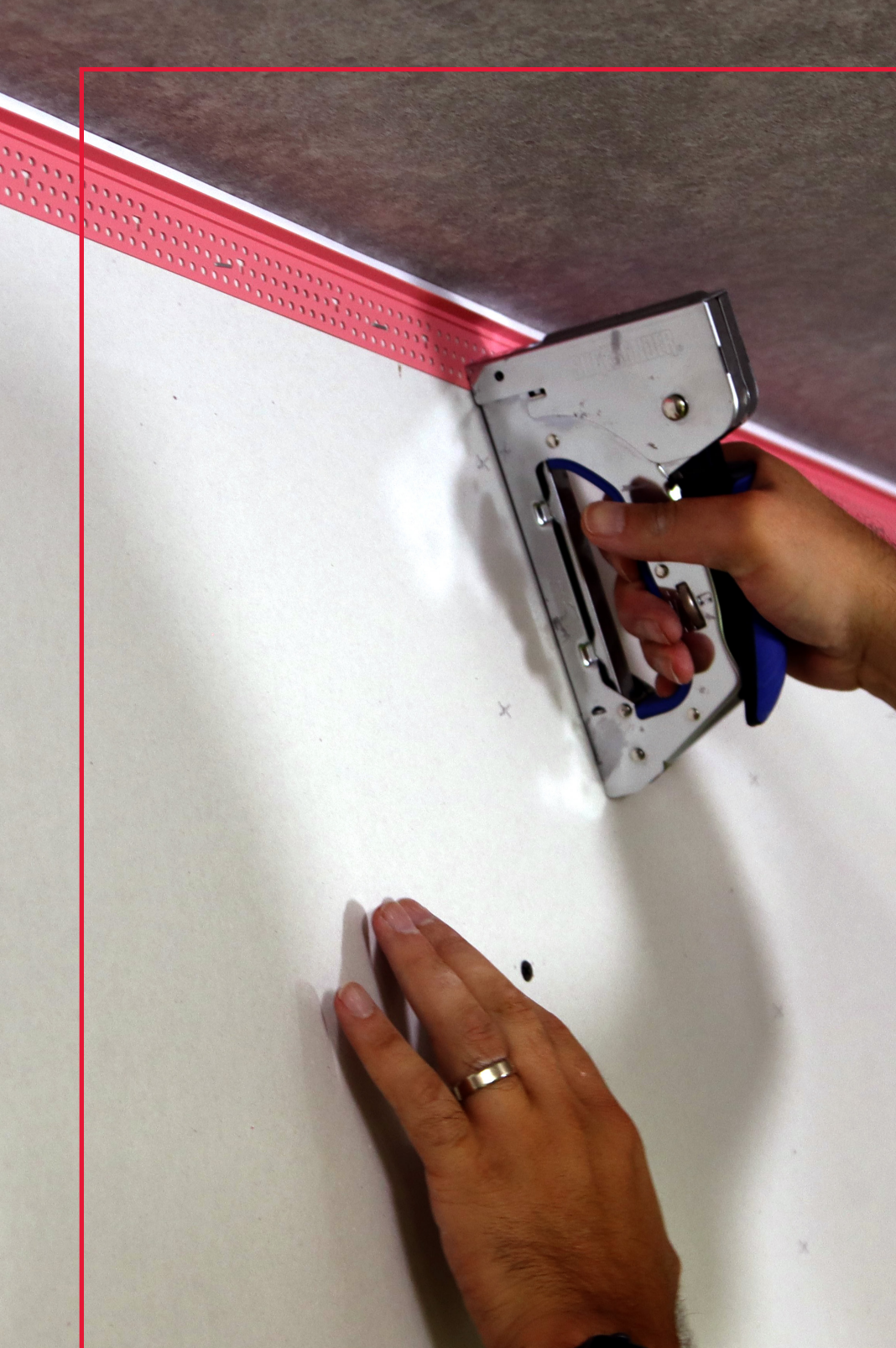

FIRESTOPPING

Product Overview



MARINO-WARE®

Firestopping

Fire Bead • Fire Gasket • HotRod XL



RETHINK STEEL FRAMING

SOLUTIONS THAT SAVE TIME AND LABOR

Fire Solutions

Achieve Fast, Reliable Head-of-Wall Fire Protection

Marino\WARE Firestopping products are designed to maximize your efficiency and minimize your hassle on the jobsite.

- Prevent the passage of fire, smoke, and toxic fumes through building joints
- Tested to UL 2079
- No cure time, minimal clean-up, and immediate inspection
- Composite vinyl intumescent accessory products offer unlimited shelf-life and no hardening of the material over time

OUR COMPANY

Marino\WARE® has been a leading supplier of cold-formed steel framing products for over 30 years. We are committed to providing a superior customer experience through:

- A vast selection of readily available products
- Innovative solutions that reduce construction costs
- Products designed to increase jobsite safety
- A knowledgeable sales team
- Comprehensive technical support and services
- An extensive distribution network
- Prompt delivery

OUR COMMITMENT

As a 100% American-owned and operated company, Marino\WARE takes pride in creating local jobs, supporting local communities, and manufacturing products that reflect the uncompromising skill and ethics of our professional team. We operate state-of-the-art production facilities in New Jersey, Georgia, and Indiana.

Visit MarinoWARE.com to experience our full line of innovative solutions.

OUR ADDED VALUE

Along with a full line of structural and non-structural framing, shaftwall/area separation products, slotted track, lath, beads and trims, Marino\WARE offers a collection of innovative framing products designed to streamline the construction process and reduce costs by saving time, labor, and materials. This collection includes well-known brands such as:

- ViperStud® drywall framing system
- SoundGuard® silent framing system
- StudRite® and JoistRite® open-web studs and joists
- Marino\WARE® Firestopping
- SureBoard® shear wall and floor assemblies
- QuickFrame® rough opening system
- ClipSource® clips and connectors

Table of Contents

Material Content.....	4
Sound Test Reports	5
FireRip®.....	6
HOTROD® Type-X.....	7
HOTROD® XL.....	8
HOTROD® BW	9
Fire Bead®	10
Super Seal-X	11
Fire Gasket®	12
FAS® STRAP	13
RBR Strap.....	14
FAS® 093X™	15
FAS® 093X™-V	16
Smoke & Sound Stop Blue (SSSB)	17
Sound Gasket®	18
FAS® J-Track	19
FAS® Track 1000	20
FAS® Track 1000DL.....	21
FAS® TRACK BT 1000.....	22

TECHNICAL SERVICES + SUPPORT | *DesignGroup*

Our commitment to quality products extends to best-in-class design support. The Marino\WARE® DesignGroup™ offers a full range of technical support and engineering services, including professionally engineered stamped shop drawings, design and installation assistance on all Marino\WARE manufactured products, and expert advice on structural, nonstructural, fire and acoustic assemblies.

If you have questions or need more information on any of the products listed in this catalog, contact our Technical Services department at technicalservices@marinoware.com, or at 866.545.1545. In most cases Technical Services representatives can provide an immediate response.

Material Content

LEED v4 for Building & Design Construction (Steel)

- MR Prerequisite: Construction and Demolition Waste Management Planning.
- MR Credit: Construction and Demolition Waste Management.
- MR Credit: Building Product Disclosure and Optimization – Sourcing of Raw Materials, Option 2.
- MR Credit: Building Product Disclosure and Optimization – Material Ingredients, Option 1.
- MR Credit: Building Life-Cycle Impact Reduction, Option 4.

Recycled Content (Steel)

- Total Recycled Content: 36.9%
- Post-Consumer: 19.8%
- Pre-Consumer: 14.4%

Recycled Content (Vinyl)

Marino\WARE Fire Bead®, Fire Gasket®, Sound Gasket®, HotRod® XL, and FAS® 093X™-V are manufactured for Marino\WARE by Trim-Tex Drywall Solutions with recycled PVC materials. These trims contain the following recycled content (RC) in the finished vinyl product:

Marino\WARE Product	Pre-Consumer RC	Post-Consumer RC
Fire Bead®	30%	0%
Fire Gasket®, Sound Gasket®	65%	0%
HOTROD® XL	42%	0%
FAS®093X™-V	48%	0%

All products are manufactured and assembled in the United States. The foam component of HOTROD® XL does not contain pre- or post-consumer recycled content and is not recyclable. It is classified as a nonregulated solid waste and is not considered hazardous as defined under the Resource Conservation and Recovery Act (RCRA) 40 CFR 261. It does not contain any ingredients that are IARC, NTP, or OSHA listed carcinogen. Its VOC Content is less than 1% by weight and less than 10 g/L.

Intumescent Fire Tape

Intertek does hereby certify that an independent assessment has been conducted on behalf of RECTORSEAL, LLC

Certificate Number: CA-42996-2021a

Conformance Criteria: California Department of Public Health (CDPH) Standard Method v1.2: Private Office and School Classroom.

Issuing Office Name & Address: Intertek Testing Services NA, Inc. 4700 Broadmoor Ave SE, Suite 200, Kentwood, MI 49512 USA

Ph: +1-616-656-7401

Product Category	Intumescent Tape
Model Name	BlazeSeal™
Product Restrictions	None
TVOC Range*	Between 0.5 and 5.0 mg/m3

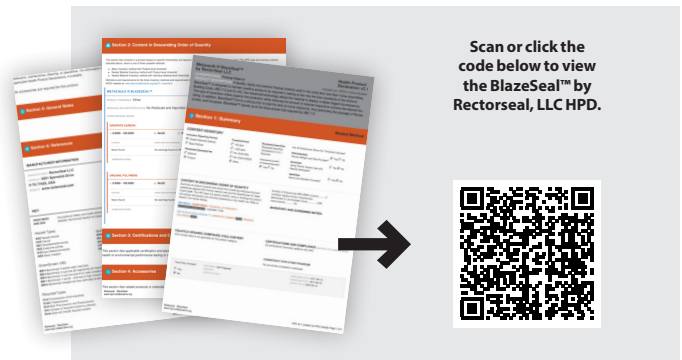

Warranty & Limitations

All products presented herein are warranted to the buyer to be free from defects in material and workmanship. The foregoing warranty is non-assignable and in lieu of and excludes all other warranties not expressly set forth herein, whether express or implied by operation of law or otherwise, including but not limited to any implied warranties of merchantability or fitness for a particular purpose. All details and specifications presented herein are intended as a general guide for the use of Marino\WARE® framing systems. These products should not be used without evaluation by a qualified engineer or architect to determine their suitability for a specific use.

Marino\WARE assumes no responsibility for failure resulting from use of its details or specifications, or for failure resulting from improper application or installation of these products.

Governing Law

All issues arising in connection with your order and all transactions associated with it shall be interpreted according to the laws of the State of New Jersey, and all actions or other proceedings arising out of such issues shall be brought only in Superior Court, State of New Jersey, County of Essex, or United States District Court for the District of New Jersey. No action may be brought more than one year after accrual of the cause of action therefore.

Sound Tests Reports

HOTROD® Type-X and HOTROD® XL Sound Test Reports

- NOAL 19-1049 STC 68 Double Wall/Double Layer HOTROD XL
- NOAL 19-1048 STC 63 HOTROD XL Double Wall
- STC-68 2 layer, 2 layer ViperStud 18 mil, 24 OC Chase Wall R13 HOTROD TL14-285
- STC-68 2 layer, 2 layer, Viper-X 18 mil, 24 OC Chase Wall R13 HOTROD XL NOAL19-1049
- STC-63 1 layer, 2_layer ViperStud 18 mil 24 OC R11 Tab Track HOTROD TL17-433
- STC-60 1 layer, 1 layer ViperStud 18 mil 24 OC R11, HOTROD TL17-430
- STC-58 2 layer, 1 layer ViperStud 18 mil 24 OC R13 Tab Track, Orfield15 1016
- STC-51 2 layer, 1 layer, ViperStud 18 mil 24 OC R13, HOTROD Orfield15-1012
- STC-51 2 layer, 1 layer ViperStud 18 mil 24 OC R11, HOTROD TL17-418
- STC-50 2 layer, 1 layer Viper-X 18 mil 24 OC R13, HOTROD XL NOAL19 117
- STC-50 2 layer, 1 layer Viper-X 18 mil 24 OC R13, HOTROD XL NOAL19-1041

Fire Bead, Fire Gasket, Sound Gasket, FAS J-Track, and RBR Strap, 093X Sound Test Reports

- NOAL 18-0763S STC 55 Single Wall Unbalanced
- NOAL 18-0762S STC 51 Single Wall Unbalanced
- NOAL 19-1046 STC 66 Double Wall Unbalanced
- NOAL 19-1045 STC 62 Double Wall Unbalanced
- NOAL 19-1043 50 STC Single Wall Unbalanced
- NOAL 18-0766 STC 66 Single Wall/Double Layer
- NOAL 18-0765 STC 63 Double Wall/Single/Double Layer
- NOAL 18-0762 STC 51 Single Wall/Single Layer/Double Layer
- NOAL 18-0763 STC 55 Single Wall/Double Layer
- TL 14-215 STC 57 093X with RC-1 Single Layer/Double Layer
- OL15-1010 STC 52 RBR Strap Single/Double Layer
- NOAL 19-0116 STC 50 Fire Bead Single Wall Unbalanced
- USG-170701 STC 42 for 4" Shaft Wall Cavity

Steel Thickness

Color Code (painted on ends)	Mil Thickness	Design Thickness (in.) ¹	Minimum Thickness (in.) ^{1,2}
None	18	0.0188 (.48 mm)	0.0179 (.45 mm)
White	33	0.0346 (.88 mm)	0.0329 (.84 mm)
Yellow	43	0.0451 (1.15 mm)	0.0428 (1.09 mm)
Green	54	0.0566 (1.44 mm)	0.0538 (1.37 mm)
Orange	68	0.0713 (1.81 mm)	0.0677 (1.72 mm)

1) Uncoated Steel Thickness. Thickness is for carbon sheet steel.
2) Minimum thickness represents 95% of the design thickness and is the minimum acceptable thickness per AISI Standards.

Patents & Intellectual Property Rights

MarinoWARE fire-rated products, or installations incorporating these products, may be covered by one or more of the following U.S. Patent #'s owned by CEMCO and used with permission under license, as well as several other patents pending:

- 7,617,643
- 8,281,552 B2
- 8,322,094
- 8,353,139
- 8,595,999
- 8,640,415
- 8,671,632
- 8,793,947
- 8,938,922
- 9,045,899
- 9,085,895
- 9,127,454
- 9,290,932
- 9,371,644
- 9,481,998
- 9,551,148
- 9,551,148 B2
- 9,616,259
- 9,637,914
- 9,683,364
- 9,739,052
- 9,752,318 B2
- 9,879,421
- 9,931,527
- 9,973,319
- 10,000,923
- 10,011,983
- 10,077,550
- 10,184,246
- 10,689,842 B2
- 10,753,084
- 11,111,666

ASTM & Code Standards

- ASTM A653/653M, A924/924M, A1003/1003M, C645 and C754.
- ASTM E3157-20 Standard Guide for Understanding and Using Information Related to Installation of Firestop Systems.
- IBC: 2012, 2015, 2018, 2021
- CBC: 2013, 2016, 2019
- ASTM E 1966: Standard Test Method of Fire Tests of Firestop Systems.
- UL 2079 5th Edition Tests For Fire Resistance of Building Joints.
- ASTM E-119 Standard Test Methods for Fire Tests of Building Construction and Material.
- Sound Tested in accordance with ASTM E90-09.
- Air leakage tests conducted for compliance with Section 713.6 of IBC and CBC.





MarinoWARE® FireRip™ is a composite steel angle encased in fire-rated drywall that provides unencumbered dynamic movement for high deflection dynamic joint applications, per UL-2079 5th edition. Available in multiple sizes, and provides 1 hr, 2 hr, or 3hr fire ratings from a single-layer profile.

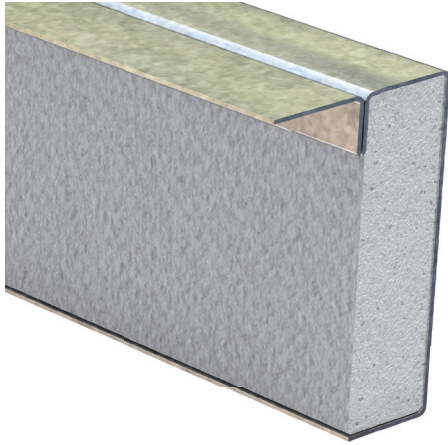

- ♥ Tested with up to 100% compression and 100% extension
- ♥ Mechanically fastened to the overhead structure at 24" on center through the horizontal attachment flange
- ♥ The encased drywall leg is set against the finished drywall concealing the deflection gap at the head-of-wall
- ♥ Provides 1 hr, 2 hr, or 3hr fire ratings from a single-layer profile
- ♥ Install joining pieces in contact to each other
- ♥ The butt joint may be sealed with sealant or joint compound and flat tape
- ♥ Can be used as a retrofit to repair damaged fire-rated fill material or to replace fire-rated fill material that was improperly installed
- ♥ Installs over the finish layer of drywall on both sides of a standard wall and on just one side (finish drywall/non-shaft side) of a shaft wall
- ♥ Provides L-rating of less than 1CFM
- ♥ Can be used with any UL certified deep leg or slotted leg track

Ordering / Packaging

Description	Part #	Size	Length	Pcs/Ctn
FireRip 2	FR2	1-1/2" x 2-3/4" x 8'	8'	4
FireRip 3	FR3	1-1/2" x 3-3/4" x 8'	8'	4
FireRip 4	FR4	1-1/2" x 4-3/4" x 8'	8'	4

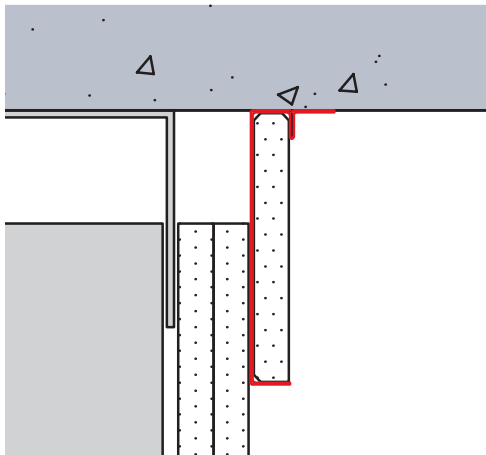

Storage / Warranty

- ♥ When stored indoors and kept dry in the original package, FireRip will provide unlimited shelf life
- ♥ See Firestop Product Warranty for details

ASTM & Code Standards

- ♥ ASTM E-84
- ♥ ASTM E-1966
- ♥ UL 2079 5th Edition
- ♥ L-Rating (air leakage) testing for compliance with International Building Code (IBC) and Canadian Building Code (CBC)
- ♥ UL listings/approvals include: HW-D-0420; HW-D-0421; HW-D-0451; HW-D-0453; HW-D-0461; HW-D-0463; HW-D-0584; HW-D-0585; HW-D-0587; HW-D-0594; HW-D-0602; HW-D-0622; HW-D-0652; HW-D-0653
- ♥ **U.S. Patent No. 11,920,343 B2**

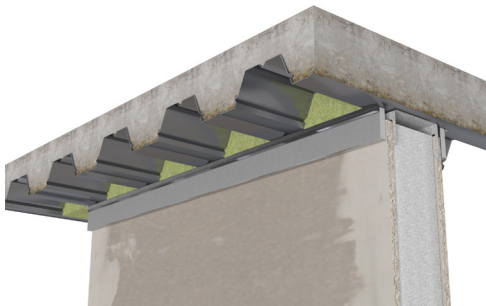



MarinoWARE HOTROD® Type-X is a compressible intumescent fire-rated deflection bead tested to UL 2079. It provides 1hr and 2 hr joint firestop solutions in joints both standard wall and shaft wall types between flat concrete or fluted metal deck applications.

- 🔴 Tested with up to 80% compression and 33% extension
- 🔴 Installed at fluted deck does not require use of additional firestop sealant or spray over mineral wool flute fillers
- 🔴 Has a rectangular profile and is easily installed by compressing it into the gap between the drywall and surrounding structure
- 🔴 Red in color for easy identification during inspection process
- 🔴 Non-hygroscopic therefore it will not absorb water
- 🔴 Provides BOTH fire and sound ratings and over time it does not shrink, harden, or separate from surrounding substrate
- 🔴 Can be installed and left exposed or covered with tape and joint compound in exposed applications
- 🔴 Optional double-sided tape for easy installation to the track or stud flange
- 🔴 For use in assemblies with STC Ratings up to 68

Ordering / Packaging

Description	Part #	Length	Pcs/Ctn
HOTROD Type-X (w Double-Sided Tape)	HOTRX121DS	40'	5 pcs / 200 ft
HOTROD Type-X (w/o Double-Sided Tape)	HOTRX121	40'	5 pcs / 200 ft
HOTROD Type-X (w Double-Sided Tape)	HOTRX11DS	20'	4 pcs / 80 ft
HOTROD Type-X (w/o Double-Sided Tape)	HOTRX11	20'	4 pcs / 80 ft

Storage / Warranty

- 🔴 When stored indoors and kept dry in the original package, HOTROD Type-X will provide unlimited shelf life
- 🔴 See Firestop Product Warranty for details

ASTM & Code Standards

- 🔴 ASTM E-84
- 🔴 ASTM E-90
- 🔴 ASTM E-1966
- 🔴 UL 2079 5th Edition
- 🔴 Cal State Fire (BML) 1451-2376:0003
- 🔴 L-Rating (air leakage) testing for compliance with International Building Code (IBC) and Canadian Building Code (CBC)
- 🔴 UL listings/approvals include: BW-S-0024, HW-D-0514, HW-D-0518, HW-D-0524, HW-D-0525, HW-D-0550, HW-D-0551, HW-D-0553, HW-D-0554, HW-D-0573, HW-D-0620, HW-D-0624, HW-D-0625, HW-D-0652, HW-S-0128, WW-D-0104, WW-S-0057, WW-S-0094
- 🔴 **U.S. Patent No. 9,683,364; 10,184,246; and 11,060,283**

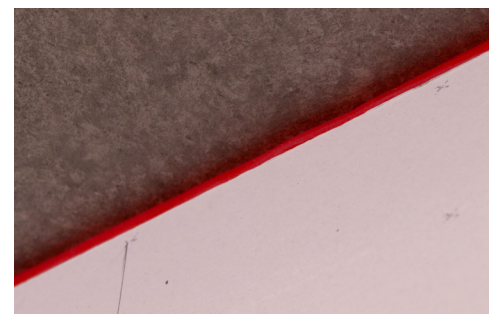
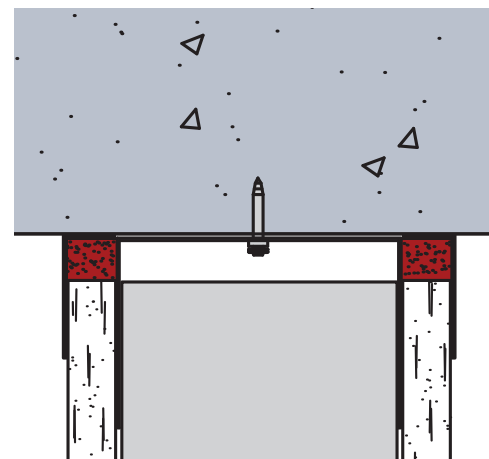
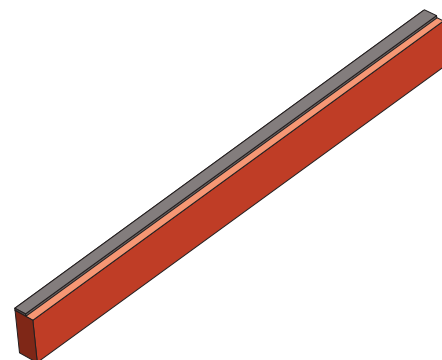



MarinoWARE® HOTROD® XL is a surface mounted fire-rated deflection bead tested to UL 2079. It provides 1 hr and 2 hr firestop solutions in joints for both standard wall and shaft wall types between flat concrete or fluted metal deck applications. It is sound tested according to ASTM E90. Sound Reports available upon request.

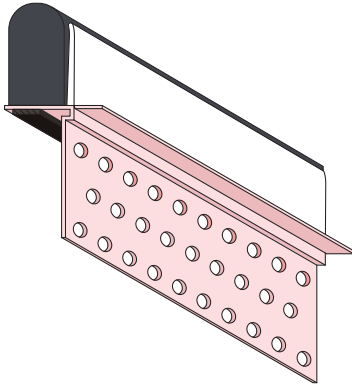

- ♥ Tested with up to 80% compression and 30% extension
- ♥ Combines compressible foam, a vinyl concealment leg, and an intumescent strip to provide an aesthetically pleasing joint
- ♥ Provides 1 hr and 2 hr fire ratings from the same profile
- ♥ Provides a single step installation of both a code compliant firestop and finished drywall accessory in one piece
- ♥ Pink perforated mud leg for ease of inspection
- ♥ Installs on the face of the drywall with a perforated mud leg incorporated to accept joint compound
- ♥ Can be used with sprayless Flute Clips to eliminate need for additional firestop sealant or spray
- ♥ Easily installs using spray adhesive and staples
- ♥ Installs fully cured and is printable
- ♥ Does not have temperature or humidity limits for installation
- ♥ For use in assemblies with STC Ratings up to 68

Ordering / Packaging

Description	Part #	Size	Length	Pcs/Ctn
HOTROD XL	HOTRODXL	1/2" x 3/4"	10'	12

Storage / Warranty

- ♥ When stored indoors and kept dry in the original package, HOTROD XL will provide unlimited shelf life
- ♥ See Firestop Product Warranty for details

ASTM & Code Standards

- ♥ ASTM E-84
- ♥ ASTM E-90
- ♥ ASTM E-1966
- ♥ UL 2079 5th Edition
- ♥ L-Rating (air leakage) testing for compliance with International Building Code (IBC) and Canadian Building Code (CBC)
- ♥ UL listings/approvals include: BW-S-0024; HW-D-0550; HW-D-0554; HW-D-0621; HW-D-0624; HW-D-0625; HW-S-0128; WW-S-0057; WW-S-0094
- ♥ **U.S. Patent No. 9,683,364; 10,184,246; and 10,914,065**

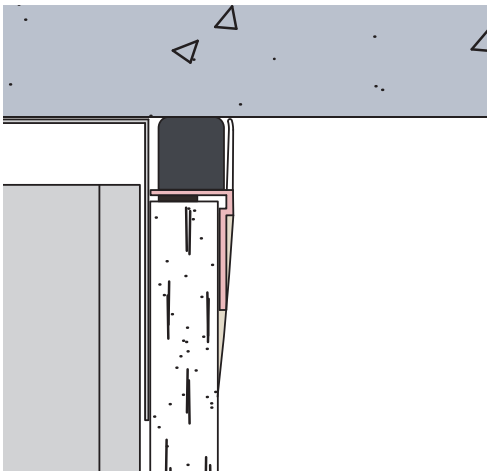



HOTROD® BW Compressible Firestop is a compressible foam tested to UL 2079. It provides 1 hr and 2 hr bottom of wall joint firestop solutions for standard wall assemblies. This pre-formed firestop product is installed flush on the GWP where the bottom track lies on the floor.

- 🔴 Installed on leg of bottom track after gypsum board is attached to studs
- 🔴 Remains flexible
- 🔴 Provides fire, thermal (F & T) & leakage (L) ratings
- 🔴 L-rating of below 1 CFM
- 🔴 Installs fully cured, unaffected by water/moisture/temperature
- 🔴 Red in color with vertical markings for easy identification during inspection process
- 🔴 Installs flush to face of gypsum board eliminating roll under of rubber base boards
- 🔴 Available in profiles for 1hr and 2hr wall assemblies
- 🔴 For use in assemblies with STC Ratings up to 68
- 🔴 Not for use in applications with permanent exposure to direct sunlight

Ordering / Packaging

Description	Part #	Size	Length	Pcs/Ctn
HOTROD BW 1HR	HOTRODBW121	1/2" x 1"	5'	80
HOTROD BW 2HR	HOTRODBW11	1" x 1"	5'	40

Storage / Warranty

- 🔴 When stored indoors and kept dry in the original package, HOTROD BW will provide unlimited shelf life
- 🔴 See Firestop Product Warranty for details

ASTM & Code Standards

- 🔴 ASTM E84
- 🔴 ASTM E90
- 🔴 ASTM E1966
- 🔴 ASTM G21
- 🔴 UL 2079 5th Edition
- 🔴 L-Rating (air leakage) testing for compliance with International Building Code (IBC) and Canadian Building Code (CBC)
- 🔴 UL listings/approvals include: BW-S-0024
- 🔴 **U.S. Patent Pending**

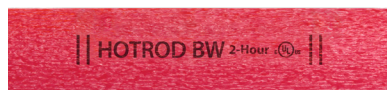
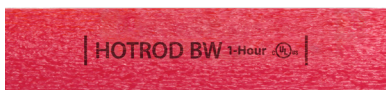
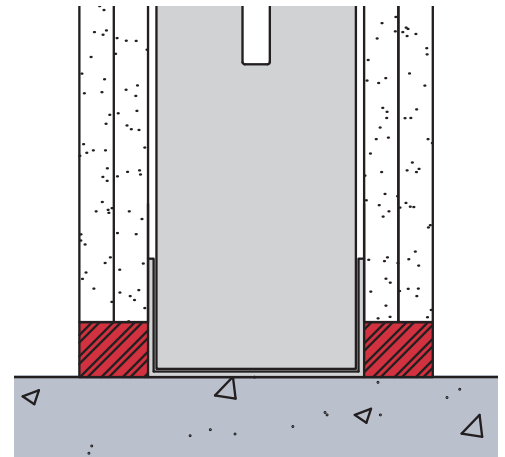
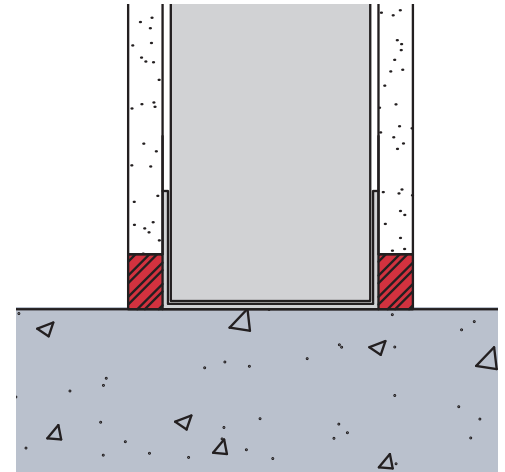

Marked for easy identification during inspection process





MarinoWARE® Fire Bead® is a surface mounted deflection bead tested to UL 2079. It provides 1 hr and 2 hr firestop solutions in joints for both standard and shaft wall assemblies.

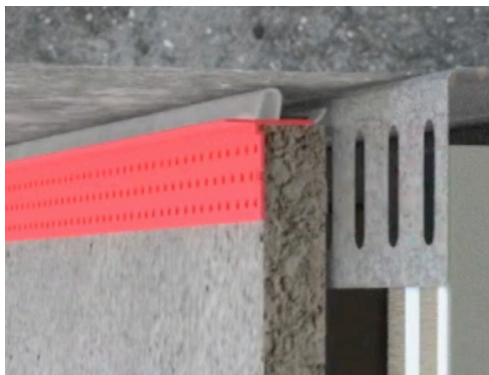
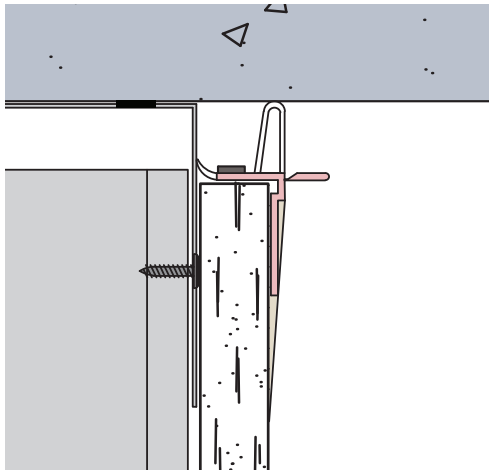
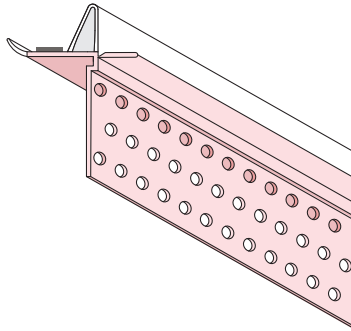

- ✔ Tested with up to 50% compression
- ✔ Remains flexible for the life of the assembly
- ✔ Can be used in top-of-wall, bottom-of-wall, and vertical joints
- ✔ Installs fully cured, unaffected by water/moisture/temperature
- ✔ Combines a vinyl bubble gasket, a perforated mud leg, and intumescent strip to provide an aesthetically pleasing joint in exposed locations
- ✔ Provides a single step installation of both a code compliant firestop and finished drywall accessory in a single component
- ✔ Installs on the face of the drywall with a perforated mud leg incorporated to accept joint compound
- ✔ Easily installs using spray adhesive and staples.
- ✔ STC ratings supported by two separate compressible sealing points. One against the deck and the other against the steel framing. STC ratings match the performance of acoustic sealant.
- ✔ Paintable

Ordering / Packaging

Description	Part #	Size	Length	Pcs/Ctn	Movement
FIRE BEAD (1 hour)	FB1	1/2" x 5/8"	10'	30	1/2" total
FIRE BEAD (2 hour)	FB2	1/2" x 1-1/4"	10'	22	1/2" total

Storage / Warranty

- ✔ When stored indoors and kept dry in the original package, FireBead will provide unlimited shelf life
- ✔ See Firestop Product Warranty for details

ASTM & Code Standards

- ✔ ASTM E-84
- ✔ ASTM E-90
- ✔ ASTM E-1966
- ✔ UL 2079 5th Edition
- ✔ Cal State Fire (BML) 1451-2376:0004
- ✔ L-Rating (air leakage) testing for compliance with International Building Code (IBC) and Canadian Building Code (CBC)
- ✔ UL listings/approvals include: BW-S-0024; HW-D-0550, HW-D-0554; HW-D-0624; HW-S-0128; WW-D-0104; WW-D-0172
- ✔ U.S. Patent No. 11,111,666; 11,873,636



MarinoWARE SUPER SEAL-X is a surface mounted deflection bead tested to UL 2079. It provides 1hr and 2hr firestop solutions in vertical joints for both standard wall and shaft wall types between dissimilar material applications.

- ✔ Tested with up to 50% compression
- ✔ Installs fully cured, unaffected by water/moisture/temperature
- ✔ Available in all black and pink vinyl with white bubble gasket
- ✔ Combines a vinyl bubble gasket, a perforated mud leg, and intumescent strip to provide an aesthetically pleasing joint when in an exposed location
- ✔ Provides a single step installation of both a code compliant firestop and finished drywall accessory in a single component
- ✔ Installs on the face of the drywall with a perforated mud leg incorporated to accept joint compound
- ✔ Easily installs using spray adhesive and staples
- ✔ Remains flexible for the life of the assembly
- ✔ Can be used in top-of-wall, bottom-of-wall, and vertical joints
- ✔ Tested in STC rated assembly
- ✔ Paintable

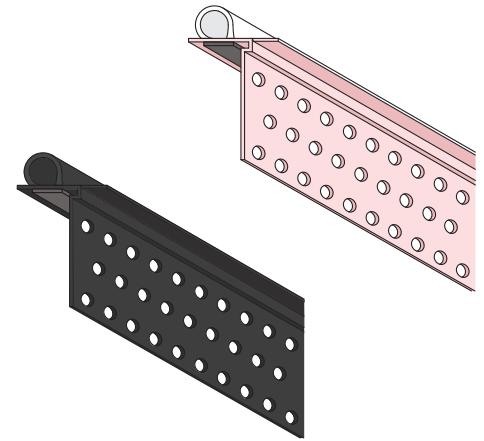

Ordering / Packaging

Description	Part #	Size	Length	Pcs/Ctn
SUPER SEAL-X (Pink)	SSX	3/8" x 1-1/8"	10'	25
SUPER SEAL-X (Black)	SSXB	3/8" x 1-1/8"	10'	25

Storage / Warranty

- ✔ When stored indoors and kept dry in the original package, Super Seal-X will provide unlimited shelf life
- ✔ See Firestop Product Warranty for details

ASTM & Code Standards

- ✔ ASTM E-84
- ✔ ASTM E-90
- ✔ ASTM E-1966
- ✔ UL 2079 5th Edition
- ✔ L-Rating (air leakage) testing for compliance with International Building Code (IBC) and Canadian Building Code (CBC)
- ✔ UL listings/approvals include: BW-S-0024; HW-D-0550, HW-D-0554; HW-D-0624; HW-S-0128; WW-D-0104; WW-D-0172; WW-D-0182
- ✔ U.S. Patent No. 11,111,666; 11,873,636

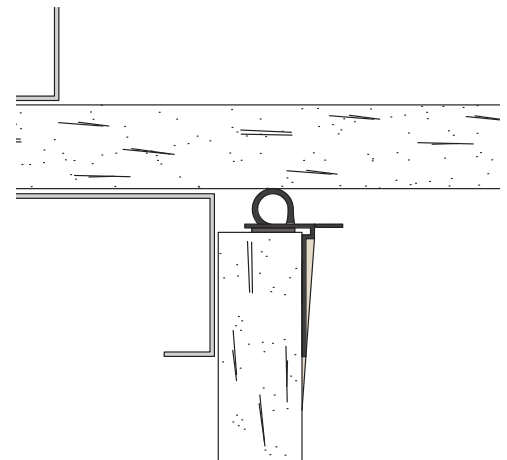



MarinoWARE® Fire Gasket® preformed firestop is composed of a vinyl frame with a bubble gasket and intumescent strip that is tested to UL 2079. It provides 1 hr and 2 hr firestop solutions in joints for both standard and shaft wall assemblies.

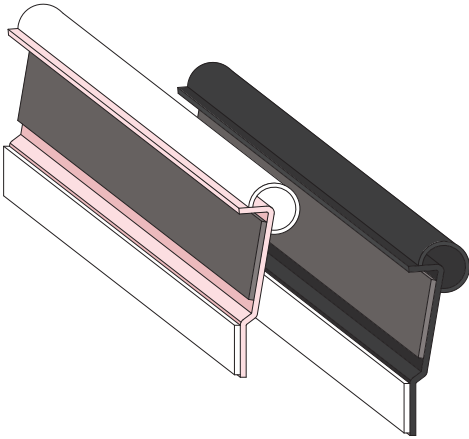

- ♥ Tested with up to 100% compression and 100% extension
- ♥ Remains flexible for life of the assembly
- ♥ Can be used in top-of-wall, bottom-of-wall, and vertical joints
- ♥ Can be installed to the track leg before or after attaching the track to the deck
- ♥ Installs fully cured, unaffected by water/moisture/temperature
- ♥ L-rating (smoke rating) of below 1 CFM
- ♥ For use in assemblies with STC Ratings up to 67
- ♥ No additional firestop sealant or spray required over metal deck mineral wool flute fillers
- ♥ Available in pink for use in concealed locations and black for exposed locations
- ♥ Paintable

Ordering / Packaging

Description	Part #	Size	Length	Pcs/Ctn	Movement
FIRE GASKET .5 (Pink)	FG.5	3/8" x 1-1/4"	5'	60	1/2" total
FIRE GASKET .5 (Black)*	FGB.5	3/8" x 1-1/4"	5'	60	1/2" total
FIRE GASKET 1 (Pink)	FG1	3/8" x 1-5/8"	5'	60	1" total
FIRE GASKET 1 (Black)*	FGB1	3/8" x 1-5/8"	5'	60	1" total
FIRE GASKET 1.5 (Pink)	FG1.5	3/8" x 2-1/4"	5'	50	1-1/2" total
FIRE GASKET 1.5 (Black)*	FGB1.5	3/8" x 2-1/4"	5'	50	1-1/2" total

Storage / Warranty

- ♥ When stored indoors and kept dry in the original package, Fire Gasket will provide unlimited shelf life
- ♥ See Firestop Product Warranty for details

ASTM & Code Standards

- ♥ ASTM E-84
- ♥ ASTM E-1966
- ♥ UL 2079 5th Edition
- ♥ Cal State Fire (BML) 1451-2376:0004
- ♥ L-Rating (air leakage) testing for compliance with International Building Code (IBC) and Canadian Building Code (CBC)
- ♥ UL listings/approvals include: BW-S-0024; BW-S-0053; HW-D-0514, HW-D-0515; HW-D-0518; HW-D-0524; HW-D-0525; HW-D-0550; HW-D-0551; HW-D-0553; HW-D-0554; HW-D-0573; HW-D-0585; HS-D-0587; HW-D-0596; HW-D-0620; HW-D-0621; HW-D-0622; HW-D-0623; HW-D-0624; HW-D-0625; HW-D-0652; HW-D-0653; WW-D-0104; WW-S-0094
- ♥ U.S. Patent No. 10,246,871; 10,753,084; 10,954,670

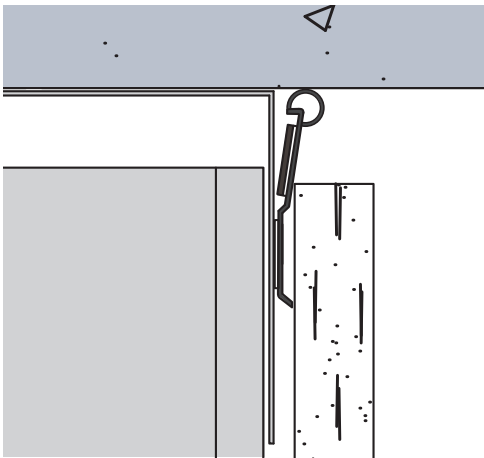



FAS STRAP is an accessory preformed galvanized steel strap with 2 intumescent strips for use as a flute cover when fire-rated walls run parallel to the flutes. It is UL tested and listed and can be used as a component of 1 hr and 2 hr fire-resistant joint systems.

- Eliminates the need for mineral wool flute fillers and bridging for attachment of the top track to the underside of the deck
- Fabricated from hot-dipped galvanized steel
- UL tested and listed and can be used as a component of 1 hr and 2 hr hour fire-resistant joint systems

Ordering / Packaging

Description	Part #	Width*	Length	Pcs/Ctn
FAS STRAP (20 ga)	FASTP105033	10-1/2"	10'	Each*
FAS STRAP (18 ga)	FASTP105043	10-1/2"	10'	Each*
FAS STRAP (16 ga)	FASTP105054	10-1/2"	10'	Each*

* Contact MarinoWARE for minimum order quantity.

Storage / Warranty

- When stored indoors and kept dry in the original package, FAS Strap will provide unlimited shelf life
- See Firestop Product Warranty for details.

ASTM & Code Standards

- AISI S240
- AISI S220
- ASTM E-84
- ASTM A653
- ASTM A924
- ASTM A1003
- ASTM C645
- ASTM E-1966
- UL 2079 5th Edition
- L-Rating (air leakage) testing for compliance with International Building Code (IBC) and Canadian Building Code (CBC).
- UL listings/approvals include: HW-D-0524; HW-D-0587
- U.S. Patent No.10,214,901**

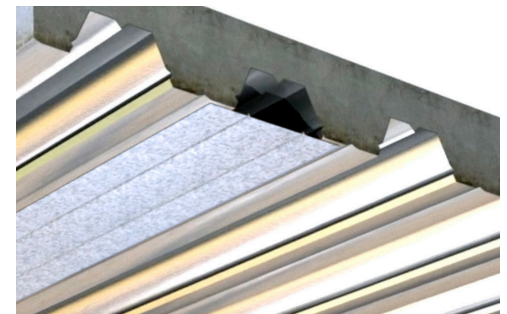
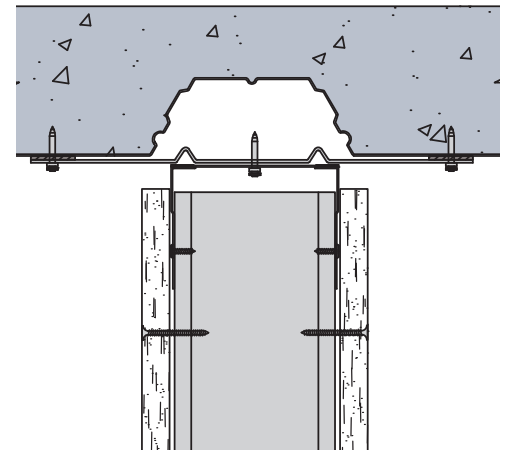
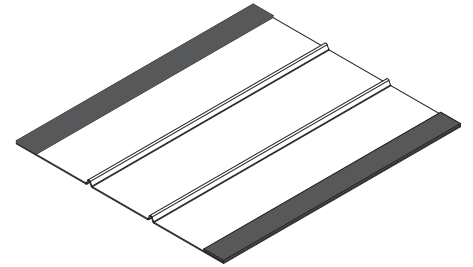



MarinoWARE RBR STRAP (Rated Base Reveal) is a preformed galvanized steel strap with an intumescent strip that provides a fire and smoke rated solution for recessed base boards, flush mounted to the face of the wall.

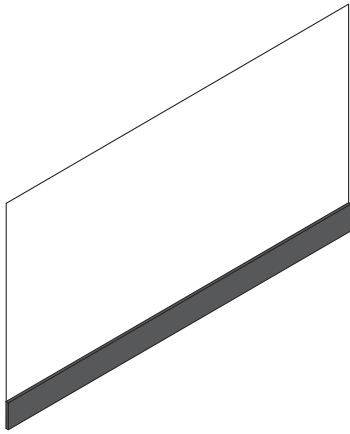

RBR STRAP eliminates the need for a second layer of drywall thus reducing in-place cost when recessed base boards or a reveal is desired.

Ordering / Packaging

Description	Part #	Width	Length	Pcs/Ctn
RBR STRAP (20 ga)	RBRFS	6"	10'	Each*

* Contact MarinoWARE for minimum order quantity.

Storage / Warranty

- ♥ When stored indoors and kept dry in the original package, RBR Strap will provide unlimited shelf life.
- ♥ See Firestop Product Warranty for details.

ASTM & Code Standards

- ♥ AISI S220
- ♥ ASTM A653
- ♥ ASTM A1003
- ♥ ASTM E1966
- ♥ UL 2079 5th Edition
- ♥ L-Rating (air leakage) testing for compliance with International Building Code (IBC) and Canadian Building Code (CBC)
- ♥ UL listings/approvals include: BW-S-0036
- ♥ **U.S. Patent No. 9,752,318 B2**

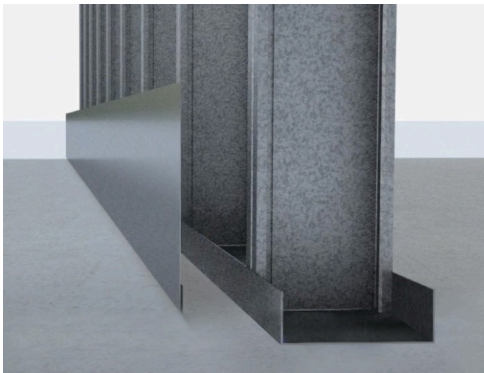



FAS-093X



MarinoWARE FAS-093X is a composite control joint constructed of metal with an integrated intumescent strip that provides fire, smoke, and sound rated solutions in vertical and horizontal control joints. It is used to relieve expansion and contraction stress within interior drywall partitions requiring vertical or horizontal control joints in gypsum wall.

- ✔ Can be used in interior drywall partitions
- ✔ Has integrated mud legs for attachment and adhesion of joint compounds
- ✔ Provides an aesthetically pleasing reveal with integrated groove
- ✔ Installs fully cured, unaffected by water/moisture/temperature
- ✔ Drywall fasteners through the perforated holes are to be used on both flanges
- ✔ Does not require drywall rips, fire sealant, or mineral wool backing within the wall cavity
- ✔ V-groove is protected removable plastic film
- ✔ Can be used in metal or wood stud wall assemblies
- ✔ Provides 1hr and 2hr fire rating from the same profile
- ✔ Paintable

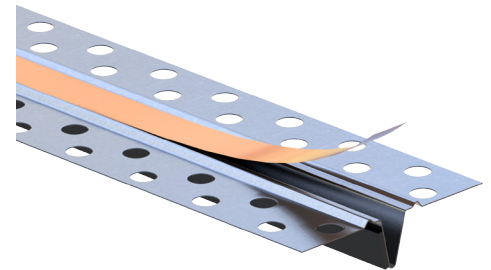

Ordering / Packaging

Description	Part #	Length	Pcs/Ctn
FAS-093X	093X	10'	20

Storage / Warranty

- ✔ When stored indoors and kept dry in the original package, FAS-093X will provide unlimited shelf life
- ✔ See Firestop Product Warranty for details

ASTM & Code Standards

- ✔ ASTM A653
- ✔ ASTM A1003
- ✔ ASTM C1047
- ✔ ASTM E-1966
- ✔ UL 2079 5th Edition
- ✔ Cal State Fire (BML) 1451-2376:0004
- ✔ L-Rating (air leakage) testing for compliance with International Building Code (IBC) and Canadian Building Code (CBC)
- ✔ UL listings/approvals include: HW-D-0596; HW-D-0621; WW-D-0172
- ✔ **U.S. Patent No. 8,671,632**

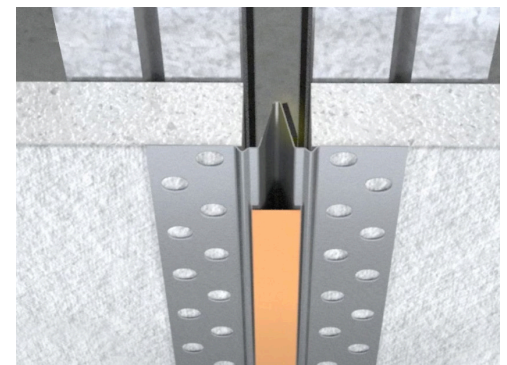
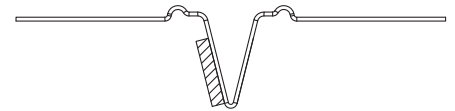



MARINO WARE

FAS[®]-093X[™]-V

FAS-093X-V is an extruded flexible PVC control joint with an integrated intumescent strip that provides fire, smoke, and sound rated solutions in vertical and horizontal control joints.

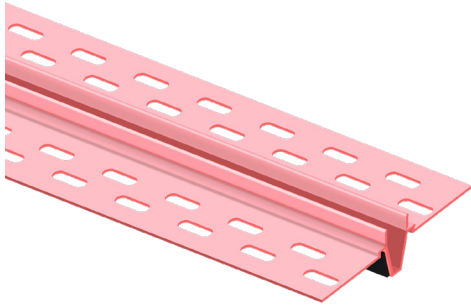

- ✔ Can be used in interior or exterior drywall partitions
- ✔ Has integrated mud legs for attachment and adhesion of joint compounds
- ✔ Provides an aesthetically pleasing reveal with integrated groove
- ✔ Installs fully cured, unaffected by water/moisture/temperature
- ✔ Easily installs using spray adhesive and staples
- ✔ Pink in color for identification in the inspection process
- ✔ Does not require drywall rips, fire sealant, or mineral wool backing within the wall cavity
- ✔ Tear away mud guide strip to protect the v-groove during installation
- ✔ Can be used in metal or wood stud wall assemblies
- ✔ Provides 1hr and 2hr fire rating from the same profile
- ✔ Paintable

Ordering / Packaging

Description	Part #	Length	Pcs/Ctn
FAS-093X-V	093XV	10'	20

Storage / Warranty

- ✔ When stored indoors and kept dry in the original package, FAS-093X-V will provide unlimited shelf life
- ✔ See Firestop Product Warranty for details

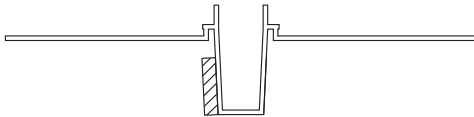

ASTM & Code Standards

- ✔ ASTM C1047-99
- ✔ ASTM D1784-03
- ✔ ASTM D3678-97
- ✔ ASTM E84
- ✔ ASTM E1966
- ✔ UL 2079 5th Edition
- ✔ L-Rating (air leakage) testing for compliance with International Building Code (IBC) and Canadian Building Code (CBC)
- ✔ UL listings/approvals include: HW-D-0596; HW-D-0621; WW-D-0172
- ✔ **U.S. Patent No. 8,671,632**





MarinoWARE® SMOKE & SOUND STOP BLUE (SSSB) is a compressible foam providing smoke and sound abatement for both dynamic and static joints. It is for use at interior building joints in non-fire-rated partitions requiring an STC rating.

- Can be used in head-of-wall, bottom-of-wall, and wall-to-wall joints
- Tested for air leakage to comply with IBC, Section 713.6
- Manufactured in light blue color that is easily identified
- Provides up to 1/2" of compression and extension
- Remains flexible
- Unaffected by water/moisture/temperature
- Odorless, installs fully cured and will not stain surrounding substrate
- Easily installs by compressing it into the gap between the board and surrounding structure after the board is attached to the framing
- Sound tested in accordance to ASTM E90, STC performance equivalent to acoustic sealant
- Not for use in applications with permanent exposure to direct sunlight

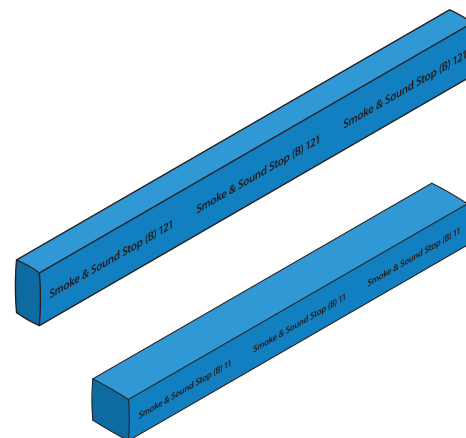

Ordering / Packaging

Description	Part #	Size	Length	Pcs/Ctn
SMOKE & SOUND STOP BLUE	SSSB121	1/2" x 1"	5'	80
SMOKE & SOUND STOP BLUE	SSSB11	1" x 1"	5'	40

Storage / Warranty

- When stored indoors and kept dry in the original package, Smoke and Sound Stop B will provide unlimited shelf life
- See Firestop Product Warranty for details

ASTM & Code Standards

- ASTM E84
- ASTM E90
- ASTM G21
- L-Rating (air leakage) testing for compliance with International Building Code (IBC) and Canadian Building Code (CBC)
- **U.S. Patent Pending**

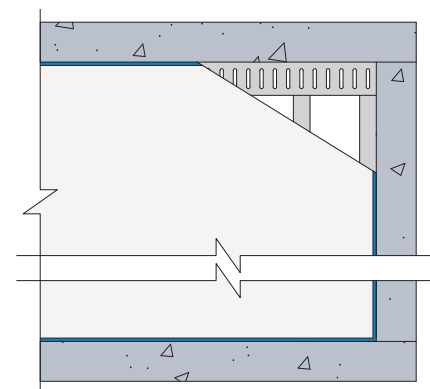



MarinoWARE® Sound Gasket® is a vinyl accessory that provides smoke and sound ratings for both dynamic and static joints. The unique vinyl profile provides a seal along the inside leg to prevent sound flanking along the leg of the slotted track and framing screws while the outer bubble gasket will compress to seal against uneven concrete.

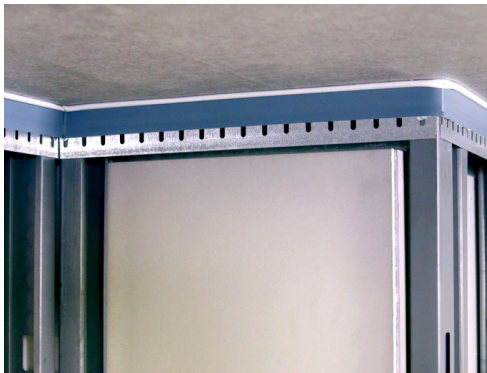
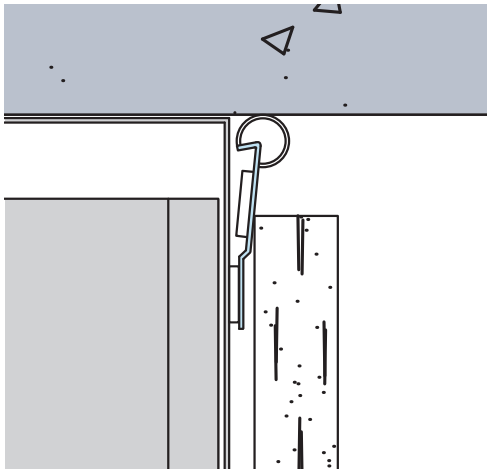
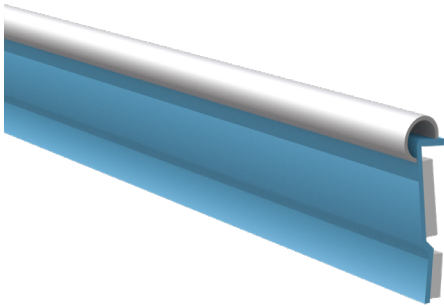

- ✔ Mechanically or adhesively fastened to the leg of the track
- ✔ Features a 3/8" hollow bubble gasket on the upper corner that is easily compressed to seal against uneven concrete or fluted decks
- ✔ Once properly installed, the Sound Gasket provides an unbreakable seal to provide long-term smoke and sound protection
- ✔ Takes the place of acoustic sealant at building joints
- ✔ Can be used on head-of-wall, bottom-of-wall, and wall-to-wall building joints
- ✔ Tested for air leakage for compliance with Section 713.6 of IBC and CBC
- ✔ Manufactured in a light blue color vinyl that is easily identified by the inspector
- ✔ Installs fully cured, unaffected by water/moisture/temperature
- ✔ Very durable and not easily damaged. Once installed, it will not delaminate, take in water, shrink, or harden over time
- ✔ Installs on both sides of the wall and comes in 10' lengths
- ✔ Can be installed to the track leg before or after fastening the track in place
- ✔ Provides up to 1-1/2" overall unencumbered movement
- ✔ For use in assemblies with STC Ratings up to 68
- ✔ Paintable

Ordering / Packaging

Description	Part #	Size	Length	Pcs/Ctn	Movement
SOUND GASKET .5	SG.5	3/8" x 1-1/4"	5'	60	1/2" total
SOUND GASKET 1	SG1	3/8" x 1-5/8"	5'	60	1" total
SOUND GASKET 1.5*	SG1.5	3/8" x 2-1/4"	5'	50	1-1/2" total

**Special order product, longer lead time*

Storage / Warranty

- ✔ When stored indoors and kept dry in the original package, Sound Gasket will provide unlimited shelf life
- ✔ See Firestop Product Warranty for details

ASTM & Code Standards

- ✔ Sound Tested in accordance with ASTM E90-09
- ✔ Achieves a Class A rating for flame spread and smoke developed when tested under ASTM E84
- ✔ Air leakage tests conducted for compliance with Section 713.6 of IBC and CBC
- ✔ **U.S. Patent No. 10,246,871; 10,753,084; 10,954,670**



FAS® J-Track has longer legs than standard J-Runner to provide greater deflection at the head-of-wall joint. It provides 3/4" overall unencumbered movement, providing the best possible L-Rating (smoke) for 1 hr and 2 hr fire ratings.

- Eliminates the installation of fire caulking of additional drywall rips
- Manufactured in 33mil thick G40 hot-dipped galvanized steel
- G60 and G90 are available only upon special request and will require extended lead times

Steel Thickness

Thickness	Design Thickness ¹	Minimum Thickness ^{1,2}	Yield	Web Sizes	Leg Sizes
33 mil	0.0346"	0.0329"	33 KSI	2-1/2", 4", 6"	1-1/2", 2-1/2"

*Notes:

1. Uncoated steel thickness. Thickness is for carbon steel.
2. Minimum thickness represents 95% of the design thickness and is the minimum acceptable thickness delivered to the jobsite, based on Section A3.4 of the AISI S100-2012.

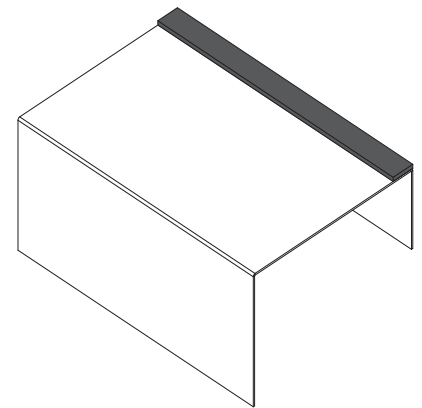

ASTM & Code Standards

ASTM A653/653M, A924/924M, A1003/1003M

ASTM A1003, A653, A924, C624, C754

AISI S240, 2012

U.S. Patent #8,640,415 Bs

ASTM E 1966: Standard Test Methods of Fire Tests of Firestop Systems

UL 2079 Tests For Fire Resistance of Building Joints, 5th Edition.

ASTM E-119 Standard Test Methods for Fire Tests of Building Construction and Material

Air leakage tests conducted for compliance with Section 713.6 of IBC and CBC

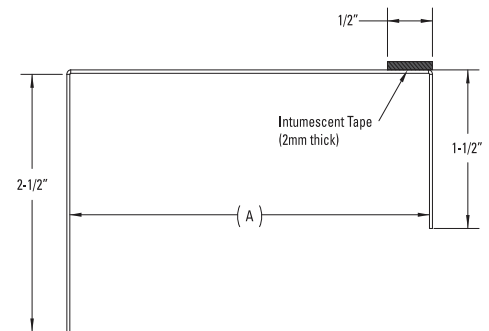

LEED v4 for Building and Design Construction

MR Prerequisite: Construction and Demolition Waste Management Planning

MR: Credit: Construction and Demolition Waste Management

MR Credit: Building Product Disclosure and Optimization - Sourcing of Raw Materials, Option 2

MR Credit_ Building Product Disclosure and Optimization - Environmental Product Declarations, Options 1 & 2

MR Credit: Building Product Disclosure and Optimization - Material Ingredients, Option 1

MR Credit: Building Life-Cycle Impact Reduction, Option 4





FAS[®] Track 1000

FAS[®] Track 1000 is a slotted deflection track that offers fire and air (smoke) protection, eliminating the need for fire and sound sealant.

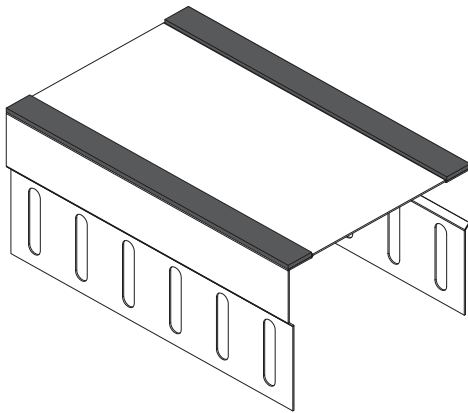

- Fabricated from hot-dipped galvanized steel
- Complies with ASTM A653 and ASTM A1003 Grade 33 Type H for 33 ksi yield strength steel for:
 - 20 gauge (33 mils) with a minimum G40 coating complying with ASTM A924
 - 18 gauge (43 mils) with a minimum G60 coating complying with ASTM A924
- Complies with ASTM A653 and ASTM A1003 Grade 50 Type H for 50 ksi yield strength steel for:
 - 16 gauge (54 mils) with a minimum G60 coating complying with ASTM A924
- Tested with Underwriters Laboratories in accordance with UL 2079

Steel Thickness

"A" Track Member Width	Flange Size ¹	Length	"G" Steel Thickness
2-1/2", 3-5/8", 4"	2-3/4"	10'	30(20DW mil), 33(20STR mil), 43(18 mil), 54(16 mil)
6", 8"	2-3/4"	10'	30(20DW mil), 33(20STR mil), 43(18 mil), 54(16 mil), 68(14 mil)

*Notes:

1. Uncoated steel thickness. Thickness is for carbon steel.
2. Minimum thickness represents 95% of the design thickness and is the minimum acceptable thickness delivered to the jobsite, based on Section A3.4 of the AISI S100-2012.

ASTM & Code Standards

ASTM A653/653M, A924/924M, A1003/1003M & C645

ASTM E 1966: Standard Test Methods of Fire Tests of Firestop Systems

UL 2079 Tests For Fire Resistance of Building Joints

ASTM E-119 Standard Test Methods for Fire Tests of Building Construction and Material

Sound Tested in accordance with ASTM E90-09

Air leakage tests conducted for compliance with Section 713.6 of IBC and CBC

LEED v4 for Building and Design Construction

MR Prerequisite: Construction and Demolition Waste Management Planning

MR: Credit: Construction and Demolition Waste Management

MR Credit: Building Product Disclosure and Optimization - Sourcing of Raw Materials, Option 2

MR Credit_ Building Product Disclosure and Optimization - Environmental Product Declarations, Options 1 & 2

MR Credit: Building Product Disclosure and Optimization - Material Ingredients, Option 1

MR Credit: Building Life-Cycle Impact Reduction, Option 4

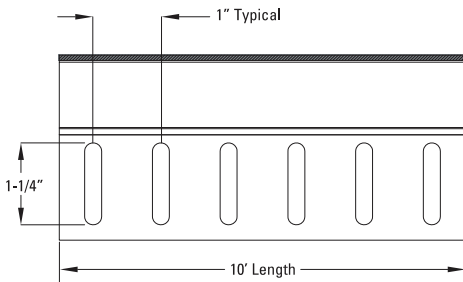
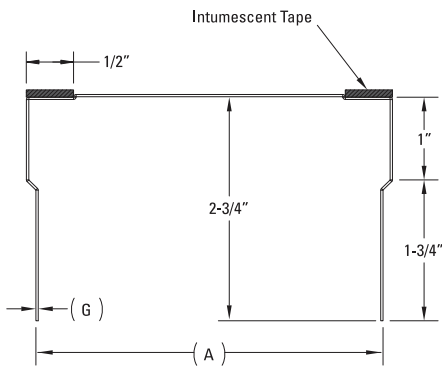



FAS® Track 1000 DL is a deflection track with 1/2" intumescent tape that offers fire and air (smoke) protection, eliminating the need for fire and sound sealant.

- ♥ Fabricated from hot-dipped galvanized steel
- ♥ Complies with ASTM A653 and ASTM A1003 Grade 33 Type H for 33 ksi yield strength steel for:
 - 20 gauge (33 mils) with a minimum G40 coating complying with ASTM A924
 - 18 gauge (43 mils) with a minimum G60 coating complying with ASTM A924
 - and Grade 50 Type H for 50 ksi yield strength steel for 16 gauge (54 mils) with a minimum G60 coating complying with ASTM A924. FAS Track 1000 DL has been tested with Underwritten Laboratories in accordance with UL 2079.
- ♥ Complies with ASTM A653 and ASTM A1003 Grade 50 Type H for 50 ksi yield strength steel for:
 - 16 gauge (54 mils) with a minimum G60 coating complying with ASTM A924
- ♥ Tested with Underwriters Laboratories in accordance with UL 2079

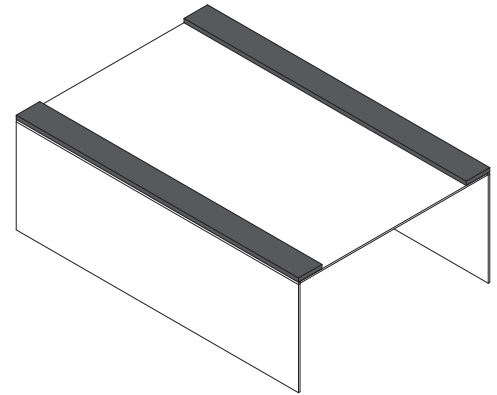

Steel Thickness

Thickness	Design Thickness ¹	Minimum Thickness ^{1,2}
30 mil	0.0312"	0.0296"
33 mil	0.0346"	0.0329"
43 mil	0.0451"	0.0428"
54 mil	0.0566"	0.0538"

Notes:
 1. Uncoated steel thickness. Thickness is for carbon steel.
 2. Minimum Thickness represents 95% of the design thickness and is the minimum acceptable thickness delivered to the job site, based on Section A3.4 of the AISI S100-2012

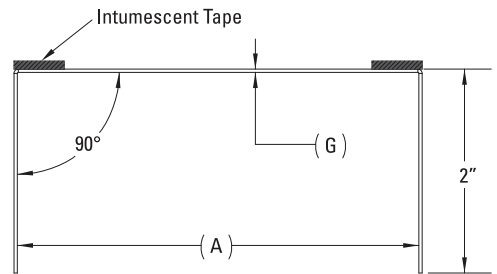

ASTM & Code Standards

- ASTM A653/653M, A924/924M, A1003/1003M, C645 & C754
- ASTM E 1966: Standard Test Methods of Fire Tests of Firestop Systems
- UL 2079 Tests For Fire Resistance of Building Joints
- ASTM E-119 Standard Test Methods for Fire Tests of Building Construction and Material
- Sound Tested in accordance with ASTM E90-09
- Air leakage tests conducted for compliance with Section 713.6 of IBC and CBC

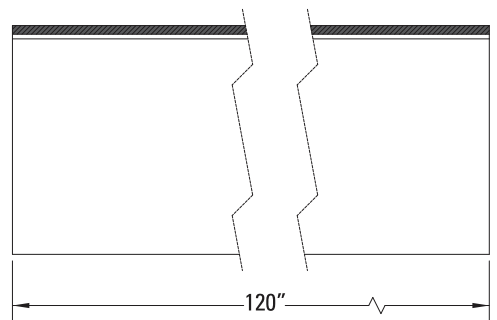

LEED v4 for Building and Design Construction

- MR Prerequisite: Construction and Demolition Waste Management Planning
- MR: Credit: Construction and Demolition Waste Management
- MR Credit: Building Product Disclosure and Optimization - Sourcing of Raw Materials, Option 2
- MR Credit_ Building Product Disclosure and Optimization - Environmental Product Declarations, Options 1 & 2
- MR Credit: Building Product Disclosure and Optimization - Material Ingredients, Option 1
- MR Credit: Building Life-Cycle Impact Reduction, Option 4





MARINO WARE

FAS[®] Track BT 1000

FAS[®] Track BT 1000 is a bottom track that offers fire and air (smoke) protection, eliminating the need for fire and sound sealant.

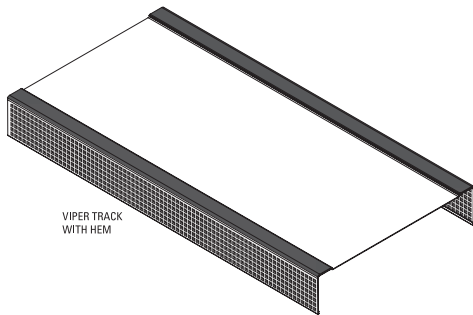

- Fabricated from hot-dipped galvanized steel
- Complies with ASTM A653 and ASTM A1003 Grade 33 Type H for 33 ksi yield strength steel for:
 - 20 gauge (33 mils) with a minimum G40 coating complying with ASTM A924
 - 18 gauge (43 mils) with a minimum G60 coating complying with ASTM A924
- Complies with ASTM A653, and ASTM A1003 Grade 50 Type H for 50 ksi yield strength steel for:
 - 54 mil (16 gauge) with a minimum G60 coating complying with ASTM A924

Steel Thickness

Thickness	Design Thickness ¹	Minimum Thickness ^{1,2}
30 mil	0.0312"	0.0296"
43 mil	0.0451"	0.0428"
54 mil	0.0566"	0.0538"

Notes:

1. Uncoated steel thickness. Thickness is for carbon steel.
2. Minimum Thickness represents 95% of the design thickness and is the minimum acceptable thickness delivered to the job site, based on Section A3.4 of the AISI S100-2012

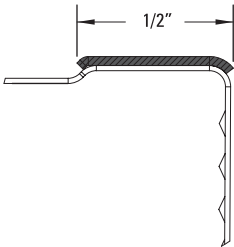

FAS Track BT 1000 (Bottom Track) Track Configurations:

"A" Track Member Width	Flange Size	Length	"G" Steel Thickness
2-1/2", 3-5/8", 4", 6"	1-1/4"	10'	30 ga (20 mil), 43 ga (18 mil), 54 ga (16 mil)

U.S. Patent 8,640,415 B2

ASTM & Code Standards

- ASTM A653/653M, A924/924M, A1003/1003M, C645 & C754
- ASTM E 1966: Standard Test Method of Fire Tests of Firestop Systems
- UL 2079 Tests For Fire Resistance of Building joints, 5th Edition
- ASTM E-119 Standard Test Methods for Fire Tests of Building Construction and Material
- Sounds Tested in accordance with ASTM E90-09
- Air leakage tests conducted for compliance with Section 713.6 of IBC and CBC

LEED v4 for Building and Design Construction

- MR Prerequisite: Construction and Demolition Waste Management Planning
- MR Credit: Construction and Demolition Waste Management
- MR Credit: Building Product Disclosure and Optimization - Sourcing of Raw Materials, Option 2
- MR Credit: Building Product Disclosure and Optimization - Environmental Product Declarations, Options 1 & 2
- ME Credit: Building Product Disclosure and Optimization - Material Ingredients, Options 1
- ME Credit: Building Life-Cycle Impact Reduction, Option 4

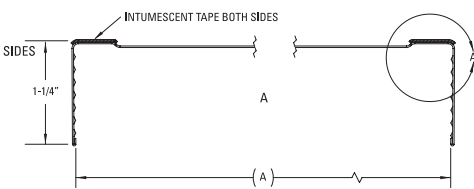

Specialists in Cold-Formed Steel Framing, Fire, + Acoustic Solutions



SOUND GUARD
THE SILENT STEEL FRAMING SYSTEM

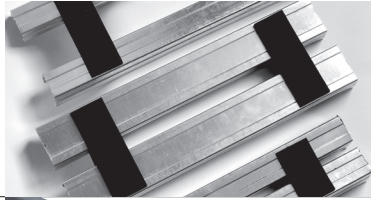

- Reduces labor and materials
- Increases available floor space
- Does not require additional bracing or resilient channel



Firestopping
Fire Bead • Fire Gasket • HotRod XL

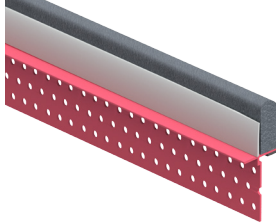

- Firestopping and sound control for building joints
- Innovative firestop devices for faster installation
- Prevents passage of fire, smoke and toxic fumes



StudRite



JoistRite

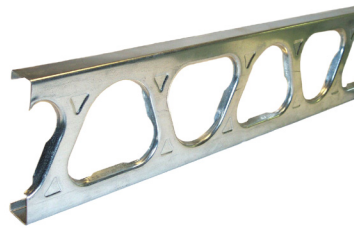

- High strength-to-mass ratio
- Increased structural performance due to lip reinforced triangular cutouts and embossments
- Efficient design for installing plumbing, heating, electrical, and other trades
- Saves construction professionals valuable time and reduces labor costs



- Unsurpassed resistance against loads imposed by seismic activity, hurricane force winds, fire, mold, impact and blast, while actively reducing sound transmission



RC-MAX

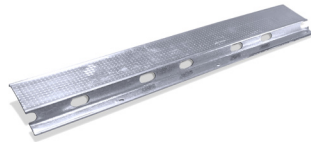

- RC-MAX is manufactured from 0.0190" 50 KSI steel for additional strength
- Offers economical means for controlling sound transmission



ClipSource



- A comprehensive line of connectors for cold formed steel framing
- Designed to facilitate quicker, more cost-effective installation, while making proper attachment of cold formed steel members easier



GenieClip

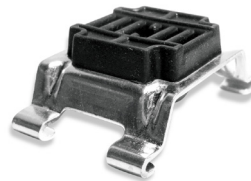

- Engineered for superior acoustical performance in reducing the transmission of airborne and impact sound through wall and floor/ceiling assemblies
- Easy and fast to install using standard steel furring channel



QuickFrame
Rough Opening System

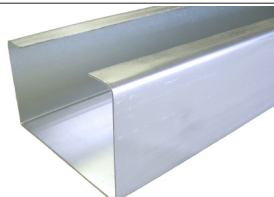

- Eliminates the need for multiple piece headers, jambs, and sills, reducing jobsite labor assembly time by more than 50%

YOUR SUCCESS DEPENDS ON QUALITY BUILDING PRODUCTS AND SO DOES OURS.

For over 30 years, Marino\WARE® has served our customers with top quality cold-formed steel framing products that deliver solutions to construction challenges.

We are committed to providing a superior customer experience through a vast selection of readily available products, innovative solutions that reduce construction costs, products designed to increase jobsite safety, a knowledgeable sales team, comprehensive technical support and services, an extensive distribution network, and prompt delivery.

Our best-in-class product development team delivers innovative solutions to installation and cost challenges with products designed to save time, labor, and materials. In addition, we utilize the latest in roll forming techniques, maintain the latest level of technology available to the steel framing industry, and strictly adhere to all ASTM specifications.

At Marino\WARE, excellence extends beyond our products. The Marino\WARE DesignGroup™ delivers comprehensive technical support and engineering services, including professionally engineered stamped shop drawings, design and installation guidance for all Marino\WARE products, and expert advice in structural, nonstructural, fire-rated, and acoustic assemblies.

Marino\WARE is 100% American-owned and operated. We take pride in creating local jobs, supporting local communities, and manufacturing products that reflect the uncompromising skill and ethics of our professional team. We operate state-of-the-art production facilities in New Jersey, Georgia, and Indiana, as well as a sales office in New York.

Visit MarinoWARE.com to experience our full line of innovative solutions.

For more information, please contact Marino\WARE® Technical Services at 866.545.1545

This technical information reflects the most current information available and supersedes any and all previous publications effective January 22, 2026 | MW_FirestoppingProductOverview | ©WARE Industries, Inc. 2026

Marino\WARE® operates state-of-the-art production facilities in New Jersey, Georgia, and Indiana, as well as a sales office in New York.

New Jersey Facility
400 Metuchen Road
South Plainfield, NJ 07080
800.627.4661
908.757.9000
Fax: 908.412.1442

Georgia Facility
777 Greenbelt Parkway
Griffin, GA 30223
800.504.8199
678.688.1312
Fax: 678.688.1379

Indiana Facility
4245 Railroad Avenue
East Chicago, IN 46312
866.636.6002
219.378.7100
Fax: 219.378.7106

New York Sales Office
51 John St. Ste. 1
Babylon, NY 11702
800.627.4667
631.691.2200
Fax: 631.691.1492

Marino\WARE® DesignGroup™
100 Hendrick Drive, Suite 200
McDonough, GA 30253
866.545.1545
678.688.7780
Fax: 770.507.2605